



Aqua Whisper Mini 170-750

Owner's Manual

Revision B - February 2014



Sea Recovery Aqua Mini 170, 350, 550 and 750

Owner's Manual

Sea Recovery Corp.
Manual PN B651220001B

Contents

Preface: About this Manual.....	vii
About Sea Recovery.....	vii
Purpose.....	vii
References.....	vii
Graphics.....	vii
Notice of Liability.....	vii
Trademarks.....	viii
Terms and Conditions.....	viii
Copyright.....	viii
Revision History.....	viii
Chapter 1: Introduction.....	11
Parts Warning.....	11
Warranty and Registration.....	11
Limited Warranty.....	11
Cleaning.....	12
Product Changes.....	12
Obtaining Warranty Service.....	12
Registration.....	12
Temperature and Pressure Effects.....	12
Safety.....	13
Disposal.....	13
Compliance.....	13
Chemical Warnings.....	14
Patent Information.....	15
Chapter 2: Specifications.....	17
System Specifications.....	17
Electrical Motor Specifications.....	18
Recommended Power Wire Size to System.....	19
Recommended Power Wire Size to Booster Pump.....	20
Chapter 3: System and Components Description.....	21
Packing List.....	21
Component Descriptions.....	21
Prefiltration Subsystem.....	21
Aqua Mini 170,350,550,&750 PandID (Piping and Interconnect Diagram).....	23
Pressurization Subsystem.....	23
Brine Discharge Subsystem.....	23
Product Water Subsystem.....	24
Fresh Water Flush Subsystem.....	24
Electronic Subsystem.....	24
Chapter 4: System Installation Precautions and Information.....	27
Special Considerations.....	27
Storage Prior to Uncrating.....	27
Uncrating.....	27
Installation Cautions.....	28
Reverse Osmosis Membrane Element Susceptibility to Chemical Attack.....	28
Distance Between Components.....	28
High Pressure Pump Preparation.....	29
Tools Required for Installation.....	29
Components Supplied by Installer or Owner.....	29
System and Component Mounting.....	30
Plumbing Connections.....	31
Tube Fitting Connections Assembly [24].....	32
UV Light Installation.....	33
Plumbing Requirements.....	34

Installation Procedure.....	34
System Commissioning.....	36
Start-up Procedure of a New Aqua Mini 170, 350, 550 & 750.....	38
Chapter 5: System Operation.....	41
System Operation Notes.....	41
Operation Cautions.....	41
Startup Procedure.....	41
High/Low Pressure Fault Lamp Explanation.....	42
Sea Recovery Mini Controller Operations.....	43
Display Menu.....	43
Configuration (Change) Menu.....	44
Configuration (Read) Menu.....	44
Fresh Water Flush button.....	45
Chapter 6: System Storage and Cleaning.....	47
R.O Membrane Element Handling and System Storage Cautions.....	47
Short Term Shutdown.....	50
Long Term Shutdown.....	51
R.O. Membrane Element Cleaning Procedures.....	52
R.O. Membrane Element Cleaning Water and Chemical Requirements.....	53
R.O. Membrane Element Cleaning Instructions.....	53
Chapter 7: Troubleshooting.....	55
System Shuts Down During Operation.....	55
Pressure Readings, Pressure Gauges, and Pressure Switches Abnormalities.....	56
Product Water Flow and Product Water Quality.....	57
3-way Product Water Diversion Valve Abnormalities.....	58
High Pressure Pump Abnormalities.....	59
Booster Pump Abnormalities.....	60
Electrical and Electronic Circuit Abnormalities.....	60
Maintenance and Repair.....	61
Weekly Quick Check.....	62
Operator Maintenance Intervals.....	62
Chapter 8: Electrical.....	65
Electrical Requirements and Information.....	65
Power Source Requirements.....	65
Electrical Connections.....	65
Motor Rotation.....	66
Recommended Wire Sizes.....	66
Wire Size Cross Reference American Wire Gauge (AWG) vs. Metric Wire Sizes.....	66
Electrical Line Drawings and Electrical Connections.....	68
Wiring Diagram Aqua Mini 12vdc.....	68
Wiring Diagram Aqua Mini 24vdc.....	69
Wiring Diagram Aqua Mini 110/220 VAC single phase.....	70
Aqua Mini 350,550,750 Electrical Diagram.....	71
Chapter 9: Maintenance and Repair.....	73
Individual Component Maintenance and Repair.....	73
UV Light Maintenance.....	73
Safety Requirements.....	74
Unit Maintenance.....	74
Quartz Sleeve.....	74
Checking for Leaks.....	76
Repairing Leaks.....	76
Measuring Performance.....	77
Verifying Lamp Operation.....	77
Obtaining Water Samples.....	77
Sampling Procedure.....	78
Periodic Maintenance Table.....	78
Quartz Sleeve Cleaning.....	78
Quartz Sleeve Reassembly.....	78
Ultraviolet Sterilizer [23].....	79
Charcoal Filter [22].....	79

The 3-way Product Water Diversion Solenoid Valve [21].....79
 Solenoid Valve Coil Check.....80
 Flow Meter [20]80
 High Pressure Pump Electric Motor81
 Back Pressure Regulator [17]81
 High Pressure Gauge [15]81
 High Pressure Pump [11].....81
 High Pressure Pump Servicing.....81
 Disassembly of the Seal Assembly.....82
 Reassembly of Seal Assembly.....82
 Reassembly of the Discharge Valve Assembly.....83
 Reverse Osmosis Membrane Element Replacement.....83
 Plankton Filter [5].....85
 Pre-filter [6] Element Replacement86
 Low Pressure Gauge [7]86
 Brine Discharge Thru Hull Fitting [1]86
 Aqua Mini 350/550/750 Booster Pump with 1/2 Horse Power Electric Motor.....86
 Booster Pump Disassembly.....86
 Booster Pump Reassembly.....87

Chapter 10: System Logs.....89

Sea Recovery Aqua Mini 170,350,550,&750 NEW SYSTEM INITIAL READINGS.....89
 Sea Recovery AquaMini 170,350,550,& 750 System Identification Information.....91
 Sea Recovery Aqua Mini 170,350,550, & 750 Daily Operation Log System Readings.....92

Chapter 11: Glossary.....93

Terms.....93

Chapter 12: Exploded Parts View.....95

A041C AQUA MINI 170.....96
 A051C AQUA MINI 350.....97
 A051C AQUA MINI 550.....98
 A051C AQUA MINI 750.....99
 A052M AQUA MINI MODULAR.....100
 BOOSTER PUMP ASSY AW 170.....101
 B016230003 BOOSTER PUMP ASSY 350 HP75 W-4.75IN IMPELLER.....102
 B016230003 BOOSTER PUMP ASSY 350 HP75 W- 4.75 IN IMPELLER.....102
 B196220017 MEMBRANE VESSEL ASSY 170.....103
 MEMBRANE VESSEL ASSY AW 350-750.....105
 Anatomy of a Spiral Wound Reverse Osmosis Membrane Element.....107
 HP PUMP-MOTOR 12VDC-24VDC AW.....108
 B156220110 HP PUMP-MOTOR 110-220 50-60 AW 170.....110
 B156230003 HP PUMP-MOTOR 110-220 50-60 1PH.....112
 B156230001 HP PUMP-MOTOR 110-220-60HZ AW350.....114
 B156230003 HP PUMP-MOTOR 110-220 50-60 1PH.....116
 B156230004 HP PUMP-MOTOR 110-220 50-60 AW 550-750 1PH.....118
 B502220003 MANIFOLD LP ASSY.....120
 B156230001M HP PUMP-MOTOR 110-220-60HZ AW350-MODULAR.....121
 B156230002M HP PUMP-MOTOR 110-220 50HZ AW 350-MODULAR.....123
 B156230004M HP PUMP-MOTOR 110-220 50-60 AW 550-750 1PH-MODULAR.....125
 B502220003M MANIFOLD LP ASSY.....127
 B502230004 CONTROL MANIFOLD ASSY.....128
 B502230003 CONTROL MANIFOLD ASSY.....130
 B502230003M CONTROL MANIFOLD ASSY MODULAR132
 1401096100 3-WAY PRODUCT WATER DIVERSION SOLENOID VALVE.....134
 B107220002 PREFILTER ASSY 170.....135
 B107230001 PREFILTER ASSY DUAL 350.....137
 B598000009 FRESH WATER FLUSH 10" HOUSING.....139
 B521220002 CHARCOAL FILTER ASSY 170-350.....141
 B107230005 COMMERCIAL PREFILTER ASSY.....143
 B107230010 OIL WATER SEPARATOR ASSY.....145
 B001220001 INSTALLATION KIT AW/SF 170.....147
 B001230001 INSTALLATION KIT AW/SF 350-750.....148
 B611000004 REMOTE ASSY LCD CONTROLLER 80' SRC.....149
 B5262000CV UV STERILIZER.....150
 B5968000XX SOFT START ASSY 115-230 V.....152

HP HOSE ASSEMBLY.....	154
AVAILABLE TUBES AND FITTINGS.....	155
TUBE COMPRESSION FITTINGS REPLACEMENT PARTS.....	158
Clean/Rinse Inlet Valve.....	159
Chapter 13: Appendix.....	161
ABS Certificate of Design Assessment.....	162
FCC Compliance.....	163
European Conformance Europe (CE).....	164

About this Manual

About Sea Recovery

Since 1981, Sea Recovery Corporation has produced water desalination systems, used in various applications, for customers around the world. Currently, Sea Recovery Corporation stands apart as a leader in advanced water desalination systems for leisure marine applications.

Sea Recovery Corp.
P.O. Box 5288
Carson, CA 90745-5288
sales@searecovery.com
www.searecovery.com



Purpose

This manual is intended for Sea Recovery's system technicians, technical support and training personnel. It contains technical information and instructions for the installation, operation, maintenance and troubleshooting of the Aqua Mini RO Desalination System. Sea Recovery's RO desalination systems are designed and engineered to function as complete, working units and are subject to cascading failure if installation, operation and maintenance instructions are not followed correctly. Thus, the intent of this manual is to familiarize you, or other installer(s) and/or operator(s) with each system component. With a core understanding of the function, importance and normal operation of each subsystem component, you will be equipped to diagnose minor problems, which, if detected early on, are typically correctable. Note that if a minor component problem is left uncorrected, it can affect the rest of the system and lead to more extensive issues and/or damage.

 **Important:** Sea Recovery encourages you to read the Aqua Mini RO Desalination System manual thoroughly before attempting installation or operation, as well as to keep the manual for future reference. By gaining a better understanding of your system, you will be equipped with the knowledge to achieve optimum performance and a longer service life.

References

All references in this manual refer to sections within this manual, unless otherwise specified.

Graphics

Graphics used in this manual are for reference and illustration purposes only, and may not represent the actual part or arrangement of parts in a customized system.

Notice of Liability

The information contained in the manual is distributed on an "as is" basis, without warranty. While every effort has been taken in the preparation of this manual, Sea Recovery Corporation shall not be held liable with respect to any liability, loss or damage caused by the instructions contained in this manual. The information contained in this manual is subject to change without notice.

Trademarks

The Sea Recovery® logo mark is a U.S. Registered Trademark and belongs to Sea Recovery Corporation with all rights reserved. Sea Recovery® is a U.S. Registered trademark of Sea Recovery Corporation. Aqua Mini™ is a trademark of Sea Recovery Corporation.

Terms and Conditions

The use of this manual acknowledges acceptance of the terms and conditions provided herewith and the agreement to comply with all applicable laws and regulations pertaining to the use of this manual. In addition, the use of this manual forms an agreement that Sea Recovery's trademarked name or Sea Recovery's trademarked logo mark are not to be used in any form or manner except with Sea Recovery Corporation's written permission. Sea Recovery Corporation holds all rights to its copyrights and trademarks, and to the material contained in this manual. Any use of such requires the written permission from Sea Recovery Corporation.

Copyright

All content included within this manual, including text, graphics, logos and images, is the property of Sea Recovery Corporation and protected by U.S. and international copyright laws. The compilation (i.e., the preparation, collection, arrangement and assembly) of all content within this manual is the exclusive property of Sea Recovery Corporation and protected by U.S. and international copyright laws. All software used in the design and manufacture of the Aqua Mini RO Desalination System is the property of Sea Recovery Corporation and protected by U.S. and international copyright laws. All computer and logic programming used in the design and manufacture of the Aqua Mini RO Desalination System is the property of Sea Recovery Corporation and protected by U.S. and international copyright laws. The content of this manual and the software, programming, and graphics used in the design and manufacture of the Aqua Mini RO Desalination System is for the purpose of operation, maintaining and repair of the Aqua Mini RO Desalination System. Any other use, including the reproduction, modification, distribution, transmission, republication, display or performance, of the content within this manual is strictly prohibited. © Copyright Sea Recovery Corporation 2008 - 2014.

Revision History

Date	Affected Page	Descriptions
April 15, 2008	Sec 7 p 7-10	Update wiring diagrams p 8-10. <i>Reported 4/9/08</i>
July 28, 2008	Sec 2 p 17-22	Update electrical wiring p 18-21. <i>Reported 7/22/08</i>
July 28, 2008	Sec 6 p 17-18	Update PCB graphic illustration p 17. <i>Reported 7/22/08</i>
July 28, 2008	Sec 7 p 7-10	Update electrical wiring and PCB graphic illustration p 8-10. <i>Reported 7/22/08</i>
July 28, 2008	Sec 9 p 29-30	Update PCB graphic illustration p 29. <i>Reported 7/22/08</i>
Sept 4, 2008	TOC p i TOC p ii	Add UV light installation p i. Add UV light maintenance p ii. <i>Reported 8/28/08</i>
Sept 4, 2008	Sec 2 p 11 Sec 2 p 22	Add reference to UV installation details p 11. Add UV installation details p 22-24. <i>Reported 8/28/08</i>
Sept 4, 2008	Sec 6 p 15 Sec 6 p 18	Add reference to UV maintenance details p 15. Add UV maintenance details p 18-22. <i>Reported 8/28/08</i>
March 22, 2010	Sec 9 p 6 and 7 of 30	Replace Booster Pump
April 26, 2010	Sec 9, Pages 10-11	Added OW Separator and Commercial Pre filter for AW-Mini 350
May 3, 2010	Preface Page xvi	Updated Electrical Specs
May 3, 2010	Section 7, Page 4	Updated Electrical Specs

Date	Affected Page	Descriptions
October 22, 2010	Section 9, Page 25	Updated New Fresh Water Flush
August 1, 2011	Section 9	Updated HP Pump, and Vessel Drawings - New 550and750
January 2014	Entire Manual	Revised and reorganized all topics within manual

Chapter 1

Introduction

Parts Warning

The major documented cause of failures and problems are from the use of third-party, non-Sea Recovery parts; improper installation; and improper operation. **Do not use parts, components from any source other than Sea Recovery!** The use of third-party, non-Sea Recovery parts is *strongly discouraged* and will result in the following consequences:

- The use of third-party, non-Sea Recovery components, spares and assemblies will damage the Sea Recovery System and/or specific components within the System.
- The use of third-party, non-Sea Recovery components, spares and assemblies will void any and all warranty of the System and/or void the affected component within the System.

 **Important:** Sea Recovery Corporation maintains inventory for immediate shipment and our Service Dealers throughout the world maintain stock of Sea Recovery parts. Always insist on Sea Recovery supplied parts in order to avoid failures, eliminate problems, and maintain your warranty.

Warranty and Registration

Sea Recovery Corporation guarantees its product, components and replacement parts, and strongly advises that customers use only Sea Recovery parts. The majority of Aqua Matic RO Desalination System problems derive from premature failure of unauthorized third party replacement parts.

 **Attention:** Using unauthorized parts will void the Sea Recovery Corporation warranty! Use of non Sea Recovery Corporation supplied parts and accessories, including but not limited to, maintenance parts, pre-filter elements, cleaning and storage chemical, spare parts, replacement parts, system components, installation components and/or system accessories, shall void all warranty expressed or implied.

Limited Warranty

Sea Recovery warrants that the Aqua Matic RO Desalination System performs according to specifications for a period of 12 months from the date of shipment. Sea Recovery's liability under this warranty is limited to repair or replacement of the Aqua Matic RO Desalination System at Sea Recovery Corporation's discretion. Under no circumstances is Sea Recovery Corporation liable for consequential damages arising out of or in any way connected with the failure of the system to perform as set forth herein. This limited warranty is in lieu of all other expressed or implied warranties, including those of merchantability and fitness for a particular purpose. The warranty period starts from the date of original shipment by Sea Recovery Corporation, or with proof of purchase from the date of sale to the original retail purchaser. The following warranty periods apply:

- System and accessories: One (1) year
- Repairs made by Sea Recovery Corporation after the original warranty period has expired: Three (3) months
- Normal, reoccurring user maintenance on the following is not covered by this or any Sea Recovery Corporation limited warranty: Sea Strainer Element, fuses, instrument calibration, cartridge filter elements and/or the centrifugal pump seal assemblies

The implied warranties, which the law imposes on the sale of this product, are expressly **LIMITED** in duration to the time period above. Sea Recovery Corporation shall not be liable for damages, consequential or otherwise, resulting from the installation, use, and/or operation of this product or from the breach of this **LIMITED WARRANTY**.



Attention: The Sea Recovery Corporation limited warranty does not cover third-party installation components. Improper installation resulting in System or component failure/performance decline is not covered by this or any Sea Recovery Corporation limited warranty. The limited warranty does not extend to any system or system component which has been subjected to alteration, misuse, neglect, accident, improper installation, inadequate or improper repair or maintenance or subject to use in violation of instructions furnished by Sea Recovery Corporation, nor does the warranty extend to components on which the serial number has been removed, defaced, or changed.

Cleaning

The Aqua Matic RO Desalination System is guaranteed to be cleanable for a minimum of one (1) year from date of shipment, providing cleaning periods are adhered to, and fouling is acid soluble metal hydroxides and calcium carbonates or alkaline soluble organic, inorganic substances and microbiological slimes. The Sea Recovery RO Membrane Element is not guaranteed against iron fouling (rust), chemical or petroleum products attack, extreme temperatures [over 120°F (49°C) under 32° F (0° C)], drying out, or extreme pressures [over 1000 psig (69 bar)]. In the event of a defect, a malfunction, or failure specifically covered by this warranty and during the warranty period, Sea Recovery Corporation will repair or replace, at its option, the product or component therein which upon examination by Sea Recovery Corporation appears to be defective.

Product Changes

Sea Recovery Corporation reserves the right to make changes or improvements in its product, during subsequent production, without incurring the obligation to incorporate such changes or improvements on previously manufactured equipment.

Obtaining Warranty Service

To obtain warranty service, the defective product or part must be returned to an authorized Sea Recovery Corporation Service Center or direct to Sea Recovery Corporation. An updated listing of Sea Recovery Corporation Factory Service Centers can be found on the Sea Recovery Corporation web site at <http://www.searecovery.com>. The purchaser must pay any transportation or labor expenses incurred in removing and returning the product to the service center or to Sea Recovery Corporation.

Registration

Sea Recovery Corporation recommends that all customers register their System immediately after delivery to ensure and guarantee product technical support and warranty.

Temperature and Pressure Effects



Note: Do not use this chart for brackish water systems and applications

As the sea water temperature gets higher, the pressure must be adjusted so that the System does not exceed 100% of its rated product water flow. Product water flow that is greater than 100% of rated capacity causes premature fouling of the RO Membrane Element, which *voids the RO Membrane Element warranty*. The System will also require more frequent cleaning. Please refer to the chart below for pressure adjustments.

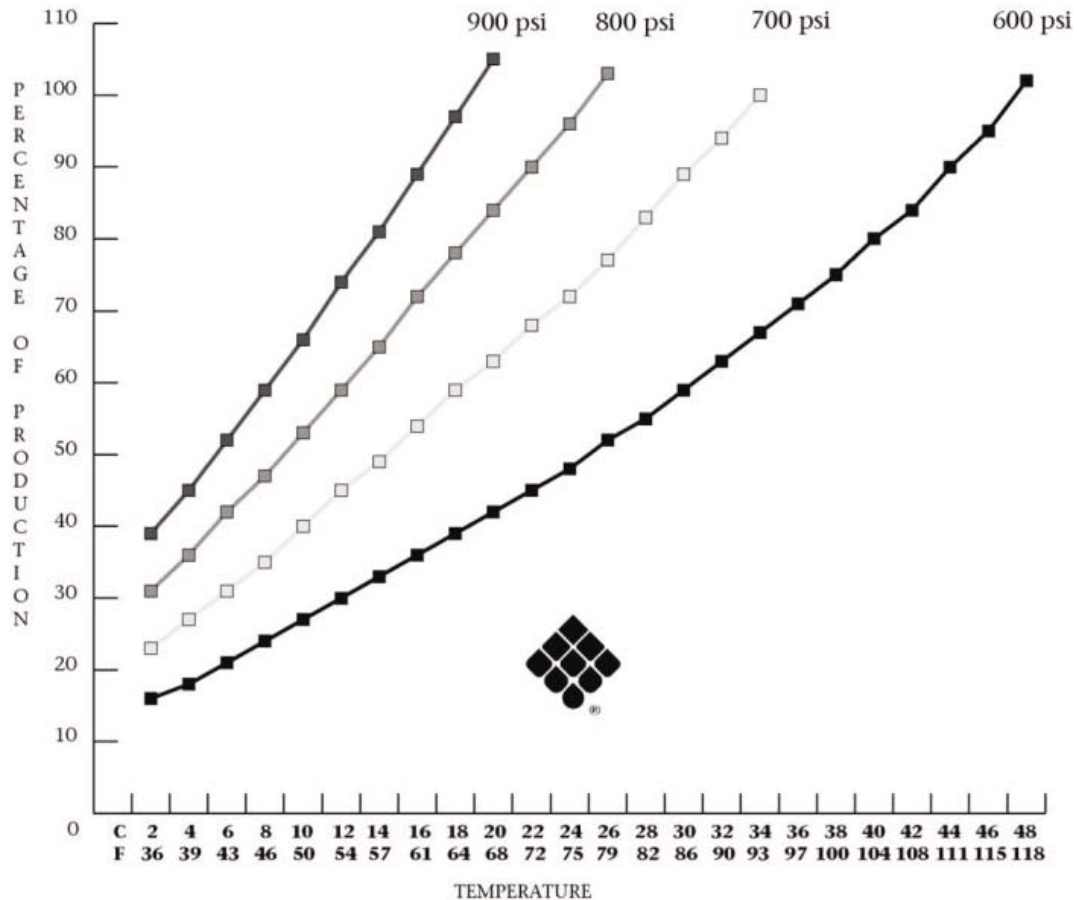
DO NOT EXCEED 100% OF RATED PRODUCTION!!!**Safety**

Parties responsible for the installation, operation, and maintenance of the Aqua Mini RO Desalination System must read this manual thoroughly and comply with the instructions and safety requirements at all times.

Disposal

If System disposal is necessary, you must comply with all federal and state environmental regulations.

Compliance

- Sea Recovery's Reverse Osmosis Desalination Systems are Type Accepted by the American Bureau of Shipping, ABS.
- Sea Recovery's Reverse Osmosis Desalination Systems comply with FCC § 15.105
- Sea Recovery's Reverse Osmosis Desalination Systems have been independently tested and determined to be in compliance with European CE (Conformité Européenne).

Please refer to the [Appendix](#) on page 161 for copies of compliance certificates.

Chemical Warnings

Sea Recovery SRC SC Storage Chemical

WARNING! CONTAINS SODIUM METABISULFITE. HARMFUL IF SWALLOWED, AVOID BREATHING DUST & FUMES. CAUSES IRRITATION TO EYES & MUCOUS MEMBRANES. DO NOT TAKE INTERNALLY. KEEP AWAY FROM FOOD.

FIRST AID: IF SWALLOWED, CALL A PHYSICIAN, GIVE TAP WATER & INDUCE VOMITING. IN CASE OF CONTACT IMMEDIATELY FLUSH EYES WITH WATER FOR 15 MINUTES & GET IMMEDIATE MEDICAL ATTENTION. THOROUGHLY WASH AFFECTED SKIN AFTER HANDLING PRODUCT.

MEDICAL PERSONNEL FAMILIAR WITH Sea Recovery "SRC SC", SYSTEM & MEMBRANE STORAGE CHEMICAL, ARE AVAILABLE 24 HOURS A DAY, 7 DAYS A WEEK, U.S.A. TOLL FREE MEDICAL EMERGENCY NUMBER: 1-800-228-5635.

FOR INDUSTRIAL USE ONLY.

Use with adequate ventilation. Prevent breathing dust and prevent contact with eyes. Thoroughly wash contacted parts after handling. Do not allow powder to become wetted with small amounts of water. Adding small amounts of water to powder may liberate irritating sulfur dioxide gas. Add powder to above specified amount of water only. Do not mix with other chemicals or cleaners. If spilled, sweep up as much as possible then flush with water to drain.

KEEP OUT OF REACH OF CHILDREN

NET CONTENTS 1.5 POUNDS (.68 Kg)

Sea Recovery SRC MCC-1 Membrane Cleaning Chemical

WARNING: CONTAINS SODIUM METASILICATE. HARMFUL IF SWALLOWED. MAY CAUSE BURNS. AVOID CONTACT WITH EYES. AVOID PROLONGED CONTACT WITH SKIN. DO NOT TAKE INTERNALLY. KEEP AWAY FROM FOOD.

FIRST AID: IF SWALLOWED, CALL A PHYSICIAN, DO NOT INDUCE VOMITING, GIVE ONE GLASS OF TAP WATER OR MILK. IN CASE OF CONTACT IMMEDIATELY FLUSH EYES WITH WATER FOR 15 MINUTES & GET IMMEDIATE MEDICAL ATTENTION. THOROUGHLY WASH AFFECTED SKIN AFTER HANDLING PRODUCT. CONTACT A PHYSICIAN IF IRRITATION PERSISTS.

MEDICAL PERSONNEL FAMILIAR WITH Sea Recovery "SRC MCC1", R.O. MEMBRANE ELEMENT ALKALINE DETERGENT CLEANING CHEMICAL, ARE AVAILABLE 24 HOURS A DAY, 7 DAYS A WEEK, U.S.A. TOLL FREE MEDICAL EMERGENCY NUMBER: 1-800-228-5635.

FOR INDUSTRIAL USE ONLY.

Use with adequate ventilation. Prevent breathing dust & prevent contact with eyes. Thoroughly wash contacted parts after handling. Do not allow powder to become wetted with small amounts of water. Add powder to above specified amount of water only. Do not mix with other chemicals or cleaners. If spilled, sweep up as much as possible then flush with water to drain.

KEEP OUT OF REACH OF CHILDREN

NET CONTENTS 1.5 POUNDS (.68 Kg)

Sea Recovery SRC MCC-2 Membrane Cleaning Chemical

DANGER: CONTAINS SULFAMIC ACID. CAUSES BURNS, EYE & SKIN IRRITATION. HARMFUL IF SWALLOWED. AVOID BREATHING DUST. DO NOT TAKE INTERNALLY. KEEP AWAY FROM FOOD.

FIRST AID: IF SWALLOWED, CALL A PHYSICIAN, DO NOT INDUCE VOMITING, GIVE ONE GLASS OF TAP WATER OR MILK. IN CASE OF CONTACT IMMEDIATELY FLUSH EYES WITH WATER FOR 15 MINUTES & GET IMMEDIATE MEDICAL ATTENTION. THOROUGHLY WASH AFFECTED SKIN AFTER HANDLING PRODUCT. CONTACT A PHYSICIAN IF IRRITATION PERSISTS.

MEDICAL PERSONNEL FAMILIAR WITH Sea Recovery "SRC MCC2", R.O. MEMBRANE ELEMENT ACID CLEANING CHEMICAL, ARE AVAILABLE 24 HOURS A DAY, 7 DAYS A WEEK, U.S.A. TOLL FREE MEDICAL EMERGENCY NUMBER: 1-800-228-5635.

FOR INDUSTRIAL USE ONLY.

DO NOT MIX WITH CHLORINATED SOLUTIONS OR COMPOUNDS. Use with adequate ventilation. Prevent breathing dust & prevent contact with eyes. Thoroughly wash contacted parts after handling. Do not allow powder to become wetted with small amounts of water. Add powder to above specified amount of water only. Do not mix with other chemicals or cleaners. If spilled, sweep up as much as possible then flush with water to drain.

KEEP OUT OF REACH OF CHILDREN

NET CONTENTS 1.5 POUNDS (.68 Kg)

Sea Recovery SRC MCC-3 Membrane Cleaning Chemical

WARNING: CONTAINS SODIUM METABISULFITE. HARMFUL IF SWALLOWED. AVOID BREATHING DUST AND FUMES. CAUSES IRRITATION TO EYES AND MUCOUS MEMBRANES. DO NOT TAKE INTERNALLY. KEEP AWAY FROM FOOD.

FIRST AID: IF SWALLOWED, CALL A PHYSICIAN, GIVE TAP WATER AND INDUCE VOMITING. IN CASE OF CONTACT IMMEDIATELY FLUSH EYES WITH WATER FOR 15 MINUTES & GET IMMEDIATE MEDICAL ATTENTION. THOROUGHLY WASH AFFECTED SKIN AFTER HANDLING PRODUCT. CONTACT A PHYSICIAN IF IRRITATION PERSISTS.

MEDICAL PERSONNEL FAMILIAR WITH Sea Recovery "SRC MCC3", R.O. MEMBRANE ELEMENT RUST REMOVER CLEANING CHEMICAL, ARE AVAILABLE 24 HOURS A DAY, 7 DAYS A WEEK, U.S.A. TOLL FREE MEDICAL EMERGENCY NUMBER: 1-800-228-5635.

FOR INDUSTRIAL USE ONLY.

Use with adequate ventilation. Prevent breathing dust & prevent contact with eyes. Thoroughly wash contacted parts after handling. Do not allow powder to become wetted with small amounts of water. Adding small amounts of water to powder may liberate irritating sulfur dioxide gas. Add powder to above specified amount of water only. Do not mix with other chemicals or cleaners. If spilled, sweep up as much as possible then flush with water to drain.

KEEP OUT OF REACH OF CHILDREN

NET CONTENTS 1.5 POUNDS (.68 Kg)

Patent Information

Certain aspects of the Aqua Mini RO Desalination System are protected by U.S. and International Patent Laws.

Chapter 2

Specifications

System Specifications

PERFORMANCE

PRODUCT WATER PRODUCED PER HOUR AND PER DAY OF OPERATION:

(+/-15% at 850 psig / 56 BAR, 77°F / 25°C and 35,000 PPM TDS Feed Water Salinity)

Model Number	per 1 hour of operation:	per 24 hours of operation:
SRC Aqua Mini 170	7 U.S. Gallons / 26.8 liters	170 U.S. Gallons / 644 liters
SRC Aqua Mini 350	14.6 U.S. Gallons / 55.2 liters	350 U.S. Gallons / 1,325 liters
SRC Aqua Mini 550	23 U.S. Gallons / 86.7 liters	550 U.S. Gallons / 2,082 liters
SRC Aqua Mini 750	31.3 U.S. Gallons / 118.3 liters	750 U.S. Gallons / 2,839 liters

SALT REJECTION (CHLORIDE ION): Minimum 99.2 %, Average 99.4%

PRODUCT WATER TEMPERATURE: Ambient to feed water temperature

SALINITY MONITORING: Automatic computer controlled electronic monitoring. Temperature compensated with the Water Quality Indicator. The salinity monitoring components of the system give a continuous readout in micromhos per cubic centimeter, are temperature compensated and of a fail-safe design.

SALINITY RANGE OF FEED WATER:

Seawater up to 50,000 PPM TDS (NaCl) (typical seawater salinity is 35,000 PPM)

TEMPERATURE RANGE: Max. 122°F / 50°C, Min. 33°F / .5°C

SYSTEM FEED WATER:

Model Number	Power Source and Cycles (Hz)	Feed Water Flow Per Minute:
SRC Aqua Mini 170	DC and AC (60Hz)	0.50 U.S. Gallons / 1.89 liters
SRC Aqua Mini 350	AC (60Hz)	1.50 U.S. Gallons / 5.68 liters
SRC Aqua Mini 170	AC (50Hz)	0.42 U.S. Gallons / 1.58 liters
SRC Aqua Mini 350	AC (50Hz)	1.25 U.S. Gallons / 4.73 liters
SRC Aqua Mini 550/750	AC (60Hz)	3.50 U.S. Gallons/ 13.30 liters
SRC Aqua Mini 550/750	AC (50Hz)	2.90 U.S. Gallons / 11.00 liters

REVERSE OSMOSIS MEMBRANE

TYPE: Specifically selected High Rejection / High Yield aromatic tri-polyamides, thin film composite, spiral wound, single pass reverse osmosis membrane element.

CHLORINE TOLERANCE: 0.1 PPM.

pH RANGE: 3-11 (typical seawater pH is 8)

SYSTEM PRESSURE

FEED WATER: Minimum 2 psi / .14 bar / .14 Kg/cm². Maximum 30 psi / 2.07 bar / 2.11 Kg/cm²

OPERATION: Seawater @ 35,000 PPM and 77 F / 25 C: Nominal 850 psi / 58.61 bar / 59.76 Kg/cm².

DIMENSIONS and WEIGHT

MODEL	WEIGHT	LENGTH	WIDTH	HEIGHT
Aqua Mini 170	70 lbs / 32 kg	26 in / 66 cm	17.85 in / 45 cm	12.2 in / 30 cm
Aqua Mini 350	127 lbs / 58 kg	37.94 in / 96 cm	19.68 in / 50 cm	15.78 in / 40 cm
Aqua Mini 550	142 lbs / 64 kg	37.94 in / 96 cm	19.68 in / 50 cm	15.78 in / 40 cm
Aqua Mini 750	150 lbs / 68 kg	46.94 in / 119 cm	19.68 in / 50 cm	15.78 in / 40 cm

EXTERNAL INSTALLATION WATER CONNECTIONS

Pipe sizes to be supplied by the installer for connection of the Sea Recovery supplied components

Aqua Mini 170

Feed Inlet:	5/8" MNPT Male National Pipe Thread Standard
Brine Discharge	1/2" MNPT Male National Pipe Thread Standard
Product	1/4" FNPT Female National Pipe Thread Standard

Aqua Mini 350-750

Feed Inlet:	5/8" MNPT Male National Pipe Thread Standard
Brine Discharge	1/2" MNPT Male National Pipe Thread Standard
Product	1/4" FNPT Female National Pipe Thread Standard

Electrical Motor Specifications

(H.P. = Horse Power; = Full Load Amperes; LRA = Locked Rotor Amperes @ Start Up)

ALTERNATING CURRENT SYSTEMS

Table 1: Aqua Mini 170

High Pressure Pump Motor				Booster Pump Motor			
VAC	H.P	FLA	LRA	VAC	H.P	FLA	LRA
12V	1/3	29	95	12V	12	5	15
24V	1/3	14	48	24V	24	2.5	8
110 - 115	1/3	6	26	110 - 115	1/8	1	20.2
220 - 230	1/3	3	13	220 - 230	1/8	.5	10

Table 2: Aqua Mini 350

High Pressure Pump Motor				Booster Pump Motor			
VAC	H.P	FLA	LRA	VAC	H.P	FLA	LRA
110 - 115	1	13	52	110 - 115	1/2	9	28
220 - 230	1	6.5	26	220 - 230	1/2	4.7	14

Table 3: Aqua Mini 550/750

High Pressure Pump Motor				Booster Pump Motor			
VAC	H.P	FLA	LRA	VAC	H.P	FLA	LRA
110 - 115	1.75	19	93	110 - 115	1/2	9	28
220 - 230	2.1	9.5	47	220 - 230	1/2	4.7	14

DIRECT CURRENT SYSTEMS

Aqua Mini 170 only (SRC SF 350 is not available in Direct Current [DC])

RECOMMENDED CIRCUIT BREAKER AMPERAGE RATING

Aqua Mini 170		Aqua Mini 350, 550, & 750	
Operating	Recommended	Operating	Recommended
Voltage	Circuit Breaker	Voltage	Circuit Breaker
12 VDC	40 Ampere	N/A	
24 VDC	20 Ampere	N/A	
115 VAC	10 Ampere	115 VAC	25 Ampere
230 VAC	10 Ampere	230 VAC	15 Ampere

Recommended Power Wire Size to System**Table 4: Aqua Mini 170**

Operating Voltage	Maximum Load Amperage	Recommended Minimum Wire Size Length of run		
		10 Ft / 3 meter	20 Ft / 6 meter	30 Ft / 9 meter
12 VDC	34 Ampere	6 AWG / 13 mm ²	4 AWG / 19 mm ²	4 AWG / 19 mm ²
24 VDC	16.5 Ampere	8 AWG / 8 mm ²	6 AWG / 13 mm ²	6 AWG / 13 mm ²
115 VAC	7 Ampere	12 AWG / 3 mm ²	12 AWG / 3 mm ²	12 AWG / 3 mm ²
230 VAC	3.5 Ampere	12 AWG / 3 mm ²	12 AWG / 3 mm ²	12 AWG / 3 mm ²

Table 5: Aqua Mini 350

Operating Voltage	Maximum Load Amperage	Recommended Minimum Wire Size Length of run		
		10 Ft / 3 meter	20 Ft / 6 meter	30 Ft / 9 meter
115 VAC	13 Ampere	12 AWG / 5 mm ²	10 AWG / 5 mm ²	10 AWG / 5 mm ²
230 VAC	9.5 Ampere	12 AWG / 3 mm ²	12 AWG / 3 mm ²	12 AWG / 3 mm ²

Table 6: Aqua Mini 550/750

Operating Voltage	Maximum Load	Recommended Minimum Wire Size Length of run		
		Amperage	10 Ft / 3 meter	20 Ft / 6 meter
115 VAC	18.2 Ampere	12 AWG / 5 mm ²	10 AWG / 5 mm ²	10 AWG / 5 mm ²
230 VAC	9.1 Ampere	14 AWG / 3 mm ²	12 AWG / 3 mm ²	12 AWG / 3 mm ²

Properly sized Power Cables

 **Caution:** DO NOT USE ROMEX TYPE SOLID CORE WIRE. SOLID CORE WIRE CAN EASILY BREAK AND WILL NOT FIT OR SEAL INTO THE SUPPLIED STRAIN RELIEFS. USE ROUND JACKETED STRANDED WIRE PREFERABLY WITH AN OUTER JACKET DESIGNATION OF SJO OR SIMILAR COMPATIBLE WITH MARINE USE AND AN OILY ENVIRONMENT. FOR DC OPERATION FINE STRAND WIRE, SIMILAR TO BATTERY CABLE, IS PREFERRED FOR MINIMAL RESISTANCE, MINIMAL VOLTAGE DROP, AND EASE OF ROUTING (EASILY FORMED AND BENT).

Recommended Power Wire Size to Booster Pump**Table 7: Aqua Mini 170**

Operating Voltage	Maximum Load	Recommended Minimum Wire Size Length of run		
		Amperage	10 Ft / 3 meter	20 Ft / 6 meter
12 VDC	5 Ampere	14 AWG / 2 mm ²	14 AWG / 2 mm ²	14 AWG / 2 mm ²
24 VDC	2.5 Ampere	14 AWG / 2 mm ²	14 AWG / 2 mm ²	14 AWG / 2 mm ²
115 VAC	1 Ampere	14 AWG / 2 mm ²	14 AWG / 2 mm ²	14 AWG / 2 mm ²
230 VAC	.5 Ampere	14 AWG / 2 mm ²	14 AWG / 2 mm ²	14 AWG / 2 mm ²

Table 8: Aqua Mini 350,500, & 750

Operating Voltage	Maximum Load	Recommended Minimum Wire Size Length of run		
		Amperage	10 Ft / 3 meter	20 Ft / 6 meter
115 VAC	6 Ampere	14 AWG / 2 mm ²	14 AWG / 2 mm ²	12 AWG / 3 mm ²
230 VAC	3 Ampere	14 AWG / 2 mm ²	14 AWG / 2 mm ²	14 AWG / 2 mm ²

Chapter 3

System and Components Description

All components supplied by Horizon Reverse Osmosis, both standard and optional, are described in this chapter, along with items that the installer must provide.

ALL STANDARD COMPONENTS AND ALL OPTIONAL ACCESSORIES.

** Denotes items supplied by installer

*** Denotes optional equipment

Packing List

When uncrating, do not discard any packaging until you have found and identified all parts! Some components are loose, or separately packaged in the shipping container.

Component Descriptions

All components supplied by Sea Recovery, both standard and optional, are described in this section along with items required or desired by the installer. The location, operation, and purpose of each major component are briefly explained in this section. The descriptions in this chapter are listed according to the ID numbers each component is given in the System Piping and Interconnect Diagram illustrated on the following page.

Throughout this manual, components are followed by a number in brackets (i.e., "Sea Strainer [3]"), which refers to the component's location in the illustration on the following page, the PandID (Piping and Interconnect Diagram).

** Denotes items supplied by installer

*** Denotes optional equipment.

Throughout this Owner's Manual, cautions are given to the technician, operator, and owner to ensure that you use only Sea Recovery supplied components, consumables, spares, and replacement parts.

Prefiltration Subsystem

This section of the system filters and delivers the feed water into the system. The raw feed water is filtered to remove suspended solids larger than 5 Micron size (5/1,000,000 of a meter). The pre-filtration protects the Reverse Osmosis Membrane Element from premature fouling.

1. Inlet Thru Hull Fitting with Forward Facing Scoop ** is the point at which the feed water enters the system. It is important that the installer utilizes a forward facing scoop so that the system receives a positive flow of water as the boat is under way.

 **Caution:** A flat inlet thru-hull fitting will cause a vacuum as the boat is under way, and this will cause loss of feed water flow and cavitation of the feed water pump and high pressure pump resulting in continual system shut down due to low feed water flow and pressure. The resulting failure of the system to remain in operation is attributed to improper installation, is the liability of the installer, and is not covered by the Sea Recovery warranty.

 **Caution:** If the thru-hull fitting is placed in a position on the underside of the hull that allows air to continually enter the thru-hull fitting, this will cause the system to continually shut down due to loss of feed water. The resulting failure of the system to remain in operation is attributed to improper installation, is the liability of the installer, and is not covered by the Sea Recovery warranty.

-
2. Sea Cock Valve ** is used in a ship installation for safety reasons to close the feed water line during repair, maintenance, and disuse of the system.
 3. Sea Strainer *** has a clear bowl with nylon body filter housing or optional bronze body containing a cleanable monel fine mesh filter screen. The Sea Strainer filters out large particulate matter and suspended particles that would otherwise prematurely foul the cartridge Prefilter Element.
 4. Booster Pump supplies a positive pressure to the Pre-filters and through to the High Pressure Pump. The Booster Pump has a performance curve of 70 Ft Head (30 PSI) at 1.0 GPM. The resulting pressure at the High Pressure Pump depends on the final installation configuration.
 5. Plankton Filter *** This optional filter assembly contains a cleanable ultra fine monel mesh screen. The mesh screen removes suspended solids or biological growth such as plankton. It also provides longer life to the Pre-filter Elements and in turn provides lower system maintenance costs.
 6. Pre-Filter This filter removes suspended solids 5 Microns and larger to protect the Reverse Osmosis Membrane from fouling.

 **Caution:** Do not use third party prefilter elements, use only Sea Recovery prefilter elements. Third party prefilter elements do not properly fit and the seams fall apart. They also allow by-pass resulting in premature fouling of the RO Membrane Element.

 **Caution:** Do not use “string wound” or “fiber” prefilter elements. These types of elements are designed for the Photographic Film Developing Industry. When used in sea water, they will plug up rapidly in 1/10th or less the time. This will cause frequent shut downs of the system and very frequent changing which will result in very high cost of maintenance.

7. Low Pressure Gauge displays the Inlet Pressure to the High Pressure Pump. The gauge assists the operator in diagnosing the Sea Strainer, Booster Pump, Plankton Filter Element, and Pre Filter Element condition.
8. Low Pressure Switch shuts the system off automatically when a plugged filter element or other condition causes a low flow situation. This protects the High Pressure Pump, the RO Membrane Element, and the Booster Pump from damage.

Aqua Mini 170,350,550,&750 PandID (Piping and Interconnect Diagram)

Piping and Interconnect Diagram (P&ID)

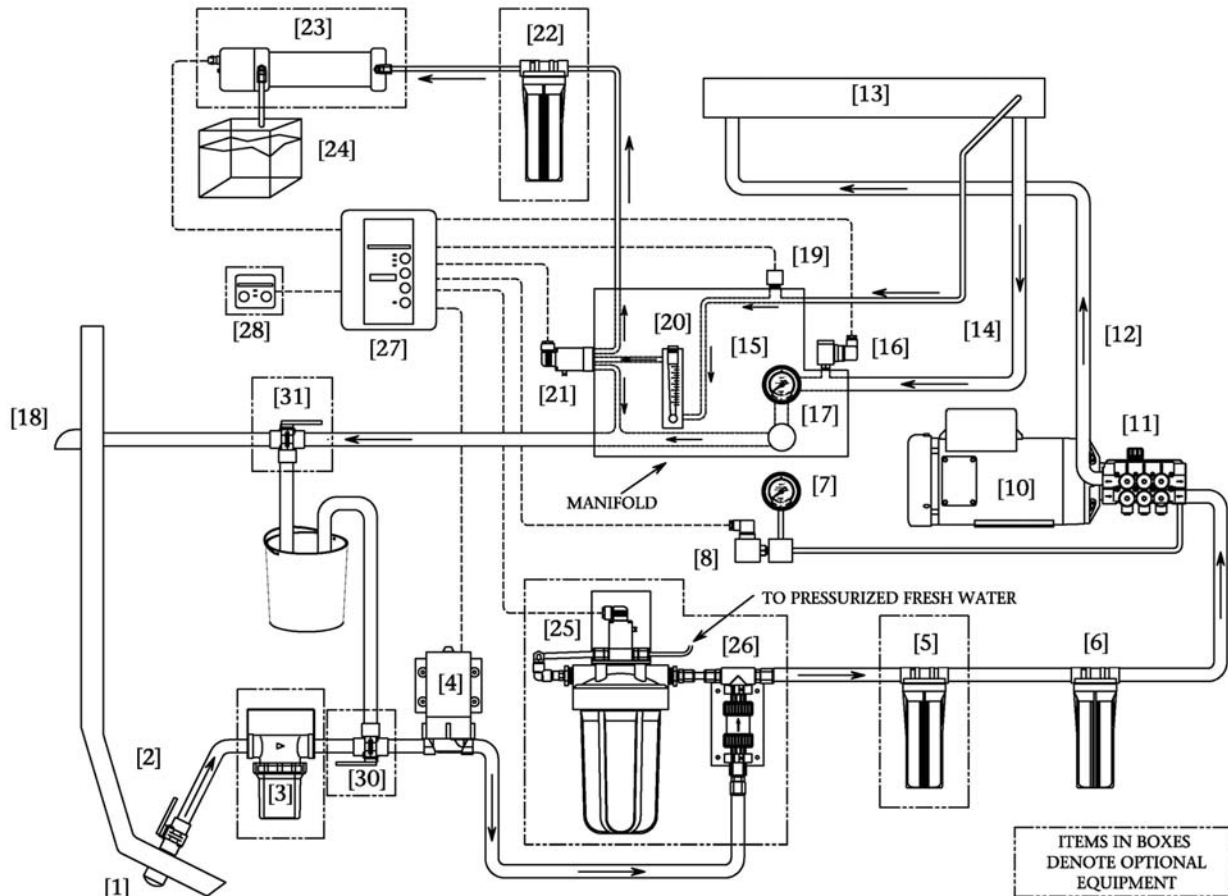

Pressurization Subsystem

Proper pressure and proper flow across the Membrane Element are two basic requirements of Reverse Osmosis.

1. High Pressure Pump Motor is directly coupled to the High Pressure Pump.
2. High Pressure Pump is a marine quality, positive displacement, ceramic plunger pump with a 316 stainless steel manifold.
3. High Pressure Hose, HP Pump Outlet to MVA Inlet, transfers pressurized sea water from the High Pressure Pump to the inlet of the RO Membrane Element.
4. RO Membrane Element and Vessel. The Membrane Element allows potable water molecules to pass through while rejecting the salt ions. Only a small percentage of the Seawater Feed becomes fresh Product Water. The remainder carries the rejected salt ions out of the RO Membrane Element in a concentrated brine stream.

Brine Discharge Subsystem

This section of the System carries the Brine Discharge exiting from the RO Membrane Element.

1. High Pressure Hose, MVA Outlet to inlet of manifold, transfers pressurized Brine Discharge Water from the Membrane Vessel Assembly to the Control Manifold Assembly.
2. High Pressure Gauge displays the RO Membrane Vessel outlet pressure.
3. High Pressure Switch automatically turns the system off in case of over-pressurization during operation.

4. Back Pressure Regulator By turning the valve adjustment handle clockwise and counterclockwise, pressure is increased and decreased accordingly. This increases and decreases the production of the RO Membrane Element.
5. Thru Hull Discharge Fitting ** should be installed above water level for discharge of the Brine Discharge Water from the system.

Product Water Subsystem

This section of the system gives a visual indication of the clarity, quantity, and quality of the product water. Post Filtration is the final step in Product Water quality control. The Post Filtration Subsystem is designed to limit unpleasant odor and taste, as well as sterilize biological matter, which may have passed through the RO Membrane Element.

1. Temperature Compensated Salinity Probe electronically determines whether the salinity content of the Product Water is acceptable. This Salinity Probe is temperature compensated and provides an accurate measurement of Product Water quality.
2. Flow Meter, Product Water measures the rate of Product Water flow, in gallons and liters per hour. It measures from the RO Membrane Element toward the Product Water Post Filtration Components.
3. 3-Way Product Water Diversion Valve, Electric Solenoid Actuated, the Controller energizes this valve to the "Potable" position when the system produces water which meets the low salinity requirement. If the Product Water being produced is "Un-potable", high in salinity, then no signal is sent to the valve, and it thus remains in the normal open position. The "fail safe" normal open position diverts the un-potable Product Water to discharge.
4. Charcoal Filter *** is designed to remove foul odors from the Product Water. Sulfurous odor (rotten eggs) is caused when decaying biological matter in the feed water section. Fresh water flushing of the system helps to minimize this.
5. Ultra Violet Sterilizer*** destroys at least 99.9% of any virus, bacteria, and other micro-organisms which may pass through the RO Membrane Element. The UV sterilizer is recommended if the Product Water Storage Tank is not otherwise treated by means such as chlorination.
6. pH Neutralizer Filter*** The product water from the system will be slightly acidic. The pH Neutralizer Filter neutralizes the pH of the product water.
7. Potable Water Storage Tank** may be any container suitable for storing Potable Water, i.e. existing water storage tank.

Fresh Water Flush Subsystem

Consists of supplied valves and required tank or container for the cleaning, rinsing, or storage of the RO System.

1. Fresh Water Flush System*** (including charcoal filter and solenoid valve) automatically flushes the system with fresh water. This process is automatic at each shut down of the system and repeats automatically every 7 days. Fresh Water Flushing replaces the seawater in the system with less corrosive fresh water, and this also reduces the biological decay as well as biological growth that naturally occur if the feed water (sea water) is not flushed from the system with fresh water.
2. Fresh Water Flush Check Valve Assembly *** included with the Fresh Water Flush Optional Assembly, isolates the Fresh Water Flush system which prevents seawater from flowing in the reverse direction through the Charcoal Filter.
3. Future Reference
4. Inlet Rinse Clean Valve *** (optional) used in conjunction with the Discharge Rinse Clean Valve [31] simplifies the storage and cleaning procedures by allowing the operator to turn a valve rather than disconnect a hose. Also used for a manual fresh water flush if the Automatic Fresh Water Flush System [25] is not installed.
5. Discharge Rinse Clean Valve *** (optional) used in conjunction with the Inlet Rinse Clean Valve [30] simplifies the storage and cleaning procedures by allowing the operator to turn a valve rather than disconnect a hose.

Electronic Subsystem

This subsystem measures water quality, controls the direction of Product Water flow, Starts and Stops the pumps, and contains the central electrical connection point of the system. It also ensures only potable Product Water passes into the Product Water Storage Tank.

1. **Salinity Controller** The controller monitors the salt content of the product water and signals the 3-Way Product Diversion Valve when Potable Water is being produced. The 3-Way Product Diversion Valve, Motors, Remote Control, and UV Sterilizer are each governed by this controller. This enclosure houses the high-voltage components of the system. It serves as the connection point for all the electrical systems such as the motors, switches, valves, and the controller.
2. **Remote Controller** *** (optional) allows for remote monitoring and/or controlling of the system.

Chapter 4

System Installation Precautions and Information

Special Considerations

1. Length of Connection Lines:
 - All connection lines should be as short and straight as possible using minimum fittings.
Increased length causes line-loss in the Feed Water line.
Increased length causes excessive pressure build up in the Brine Discharge line.
Increased length causes excessive pressure build up in the Product Water line.
 - The connection lines must not be “kinked”.
Kinks in the Feed Water line cause cavitation and continual System shut down.
Kinks in the Brine Discharge line cause excessive pressure build up and damage.
kinks in the Product Water line cause excessive pressure build up and damage.
2. Accessibility
 - This is a simple rule: Install the system and it’s supporting components in an accessible manner. The Aqua Mini system requires regular operator maintenance such as filter element changing. As with any Electro Mechanical system utilized in the Marine environment the Aqua Mini system will require repair from time to time. Hidden or out of reach items may become forgotten, not maintained, and cause damage to other system components.
 - The Electrical Control Panel Touch Pad and the Back Pressure Regulator must be accessible for starting, stopping, and adjusting pressure of the system.

Storage Prior to Uncrating

1. Adhere to crate markings
 - DO NOT store in direct sunlight;
 - DO NOT store above 120 degrees F / 50 degrees C;
 - DO NOT freeze;
 - DO NOT store longer than 4 months without flushing with storage chemical;
 - STORE ONLY on base with ARROWS UP.

Uncrating

1. DO NOT DISCARD ANY PACKAGING UNTIL YOU HAVE FOUND AND IDENTIFIED ALL PARTS!
2. Remove the Aqua Mini system from the shipping carton.
3. Some of the components are loose or separately packaged in the shipping container.
4. Refer to the prior two pages illustrating the contents of the System.

Installation Cautions

1. Do not over tighten PVC fittings. If threaded pipe fittings leak after installation, remove the fitting, clean the mating threads, apply 3 to 4 wraps of Teflon tape to the male threads and thread the parts back together. PVC fittings should only be hand tightened.
2. The Inlet Connection [1], Sea Strainer [3], Inlet 3-way Clean/Rinse Valve [30], and Booster Pump [4] should be below water level. This will aid the Booster Pump in priming.
3. Always allow hoses and tubes to enter and exit straight from the connection for a minimum of one inch prior to a bend
4. Avoid skin and eye contact with the membrane packaging solution. In case of skin contact, rinse the skin thoroughly with water. In case of eye contact, flush repeatedly with water and notify a physician immediately. Membrane Element are stored in sodium bisulfite.
5. NEVER mount any liquid holding component of the system above an electrical or electronic circuit or device. Extensive damage to the electrical or electronic device or circuit will result if water spills from the system during maintenance and or component failure.

Reverse Osmosis Membrane Element Susceptibility to Chemical Attack

 **Caution:** Do Not expose the Sea Recovery System to intake Feed Water containing:

Hydrogen peroxide	chloramines	chloramines-T	N-chloroisocyanurates
Chlorine dioxide	hypochlorite	chlorine	iodine
Bromine	Bromide	phenolic disinfectants	petroleum products

Any chemical, not approved in writing by Sea Recovery.

USE OF NON-AUTHORIZED OR MISUSE OF AUTHORIZED CHEMICALS VOIDS SYSTEM WARRANTY. Do not connect any water line to the System that may contain any of the above listed chemicals. Example: Do not connect the inlet of the System to the ship's potable water system if the system contains chlorinated or brominated water. These chemicals destroy the copolymer components within the system. These oxidants and others also damage the R.O. Membrane Element. The Sea Recovery Optional Fresh Water Flush Accessory removes chlorine and bromine from the ship's potable water system.

Distance Between Components

1. 20 feet (6 meters) of 1/2" (12.7 mm) ID inlet suction hose is supplied for connecting:

Outlet of	to	Inlet of
Sea Cock Valve [2]		Sea Strainer [3]
Sea Strainer [3]		Inlet 3-Way Clean/Rinse Valve [30]
Inlet 3-way Clean/Rinse Valve [30]		Rinse/Clean bucket or container
Inlet 3-way Clean/Rinse Valve [30]		Booster Pump [4]
Booster Pump [4]		Fresh Water Flush Check Valve [26]
Fresh Water Flush Check Valve [26]		Plankton Filter [5]
Plankton Filter [5]		Prefilter [6]
Prefilter [6]		High Pressure Pump [11]

2. 20 feet (6 meters) of 3/8" O.D. (9.5 mm) nylon tube is supplied for connecting:

Outlet of	to	Inlet of
System Brine Discharge		Discharge 3-way Clean/Rinse Valve [31]
Discharge 3-way Clean/Rinse Valve [31]		Rinse/Clean Bucket or container
Discharge 3-way Clean/Rinse Valve [31]		Thru Hull Discharge fitting [18]

3. 30 feet (9.14 meters) of 1/4" (6.35 mm) OD nylon tubing is supplied for connecting:

Outlet of	to	Inlet of
Potable Product Water from System		Charcoal Filter [22]
Charcoal Filter [22]		U.V. Sterilizer [23]
U.V. Sterilizer [23]		pH Neutralizing Filter
pH Neutralizing Filter		Boats Potable Water Storage Tank [24]

High Pressure Pump Preparation

1. Remove the shipping tape from the High Pressure Pump Oil Fill Cap to expose the Oil Fill Cap air breather hole.
2. Ensure that the pump oil level is even with or higher than the center of the pump sight glass. Damage to the High Pressure Pump will occur if the wrong oil is used in its crankcase. Use only Sea Recovery supplied pump oil.

Tools Required for Installation

Not all installations are typical, therefore, it is recommended to have a full set of Mechanic's and Electrician's tools available. No special system tools are required for installation. A separate TDS Meter, available from Sea Recovery will assist in confirming system product water quality. A volt/ohm meter (VOM) is required for system installation and commissioning to ensure proper electrical power and connection.

Components Supplied by Installer or Owner

 **Caution:** All fittings, valving, and piping installed prior to, within, and after the Sea Recovery system must not contain iron. They must be non-ferrous material (not containing iron). Iron fittings or piping will cause rust fouling and failure of the R.O. Membrane Element. The resulting failure of the R.O. Membrane Element is attributed to improper installation, is the liability of the installer, and is not covered by the Sea Recovery warranty.

1. Water Connections to be supplied by the installer

Table 9: Aqua Mini 170

Feed Inlet:	5/8" MNPT Male National Pipe Thread Standard
Brine Discharge	1/2" MNPT Male National Pipe Thread Standard
Product	1/4" FNPT Female National Pipe Thread Standard

Table 10: Aqua Mini 350, 550 & 750

Feed Inlet:	5/8" MNPT Male National Pipe Thread Standard
Brine Discharge	1/2" MNPT Male National Pipe Thread Standard
Product	1/4" FNPT Female National Pipe Thread Standard

2. Inlet Thru Fitting with Forward Facing Scoop [1].

The inlet Thru Hull Fitting must be dedicated to only the Sea Recovery system. It is important that the installer utilizes a forward facing scoop so that the system receives a positive flow of water as the boat is under way. The fitting must be installed on the boats hull in a position that provides continual feed water flow without air to the system.

-
-  **Caution:** A flush inlet thru-hull fitting will cause a vacuum as the boat is under way, and this will cause loss of feed water flow and cavitation of the Booster Pump and High Pressure Pump resulting in continual system shut down due to low feed water flow and low pressure. The resulting failure of the system to remain in operation is attributed to improper installation, is the liability of the installer, and is not covered by the Sea Recovery warranty.

 -  **Caution:** The Aqua Mini system must receive an uninterrupted supply of feed water without air. If the thru-hull fitting is placed in a position on the underside of the hull that allows air to continually enter the thru-hull fitting, this will cause the system to continually shut down due to loss of feed water. The resulting failure of the system to remain in operation is attributed to improper installation, is the liability of the installer, and is not covered by the Sea Recovery warranty.

 -  **Caution:** The Aqua Mini system must not be tied into another existing auxiliary water line already supplying another accessory on the boat. Using one Thru Hull fitting for other equipment will cause the Aqua Mini system to draw air or cavitate leading to continual system shut down. The resulting failure of the system to remain in operation is attributed to improper installation, is the liability of the installer, and is not covered by the Sea Recovery warranty.

 -  **Caution:** If the Aqua Mini system is connected to a Sea Chest or Stand Up Pipe, do not plumb the Aqua Mini system feed line to the “top” of the Sea Chest or Stand Up Pipe. If plumbed into the top of these feed water arrangements, the Aqua Mini system will experience continual shut down due to air inducement into the system. Plumb the Aqua Mini to the “bottom” of such feed water arrangements to ensure a continual air free supply of feed water to the system.

3. Inlet Sea Cock Valve [2]

Quarter turn ball valve min. 1/2” size, with a 1/2” MNPT connection for mating to the supplied 1/2” FNPT fitting.

4. Brine Discharge Thru Hull Fitting [18]

Minimum 1/2” size with a 1/2” MNPT connection for mating to the supplied 1/2” FNPT fitting. The Brine Discharge Thru Hull Fitting should be installed above water level. No valves should be installed in this line. If a closed valve was the cause of damage and failed the system, it will not be covered by the Sea Recovery Warranty.

5. Connection to the boat’s Potable Water Storage Tank [24]

Requires a 1/4” FNPT connection for mating to the supplied 1/4” MNPT fitting. In order to avoid problems such as reverse flow (osmosis) from the tank to the system and chlorination attack of the R.O. Membrane Element, the fitting must terminate above the maximum water level. No valves should be installed in this line. If a closed valve was the cause of damage and failed the system, it will not be covered by the Sea Recovery Warranty.

Refer to Electrical Specifications at the beginning of this booklet.

System and Component Mounting

The following steps discuss the installation of the Aqua Mini 170, 350, 550 & 750. The prior illustrations show the system installed in the port-aft section of a boat as an example. It is understood that this location or configuration may not always be possible, and there are a variety of locations the system may be mounted. The components in the illustrations are spaced far apart only to allow illustration of the hose and tube connections between components.

The mounting surfaces must be flat in order to avoid warping of brackets and frames. Use appropriate shims on uneven surfaces to ensure that mounting of the system components does not cause bending or warping.

1. The Optional Sea Strainer is mounted below water level between the Inlet Sea Cock Valve and Booster Pump. Allow at least 4 inches (10 cm) of clearance below the bowl to access the mesh screen for cleaning or replacement.
2. The Optional Fresh Water Flush Filter Canister is mounted to a Vertical Bulkhead. Allow at least 4 inches (10 cm) of clearance below the bowl for element replacement.

3. Mount the Fresh Water Flush Check Valve Assembly vertically in close proximity to the Booster Pump, Fresh Water Flush Filter Canister, and the Pre-Filter.
4. The Booster Pump is mounted to a flat surface using the 4 supplied #10 x 1 1/4" long Type "A" screws. The Booster Pump is mounted below water level to assist priming, and in an accessible location to allow access for maintenance. Mount Booster Pump close to the Inlet Thru Hull/ Sea Cock Valve and the Sea Strainer (if purchased). If the booster pump is mounted vertically, mount the motor up and pump head down. Do not mount the pump head above the motor else motor damage will occur if the pump or its fittings should develop a leak.
5. The Optional Plankton Filter is mounted inline between the Booster Pump and the Pre Filter. Allow at least 4 inches (10 cm) of clearance below the bowl for element replacement.
6. The Pre-filter is mounted to a bulkhead using the 4 supplied #10 Type "A" 1" long screws. Allow minimum 4 inches (10 cm) below the bowl for filter element removal. Feed water may spill during filter element replacing. Therefore, Do Not mount the prefilter above any electrical or electronic component
7. The Optional Charcoal Filter is mounted to a vertical bulkhead using the 4 supplied #10 x 1" long Type "A" screws.
8. The system is mounted to a flat surface using the 4 supplied 1/4" x 1" Type "A" screws.
9. Mount the UV Sterilizer (not shown) to a bulkhead directly after the Charcoal Filter. The UV should be mounted vertically to displace air from the sterilizing chamber, with the electrical fitting on the top. The UV should be plumbed with the inlet on the bottom and the outlet on top. Horizontal mounting is acceptable with outlet port on top (pointed up) to displace air.
10. Attach the supplied Sea Cock Inlet Fitting Assembly, 1/2 " FNPT elbow with attached 1/2" hose barb to the boats Sea Cock 1/4 turn ball valve.
11. Attach the supplied Brine Discharge Outlet Fitting Assembly, 1/2 " FNPT elbow with attached 3/8" Tube Fitting to the boats Over board Discharge Fitting.
12. Attach the supplied Product Water Tank Connector 1/4" MNPT x 1/4" Tube Fitting to the 1/4" FNPT tap at the Potable Water Tank.

Plumbing Connections

- ⊘ Caution:** Always allow slack in water lines. Allow the line to enter or leave from the fitting in a straight manner for several inches to ensure proper connection, to relieve stress to the fitting and tube or hose, and to allow ease of detachment and reattachment during maintenance or repair. If water lines are pulled tight causing them to bend at the fitting they will leak, allow air to enter, fail prematurely, and/or break the fitting that they are attached to.

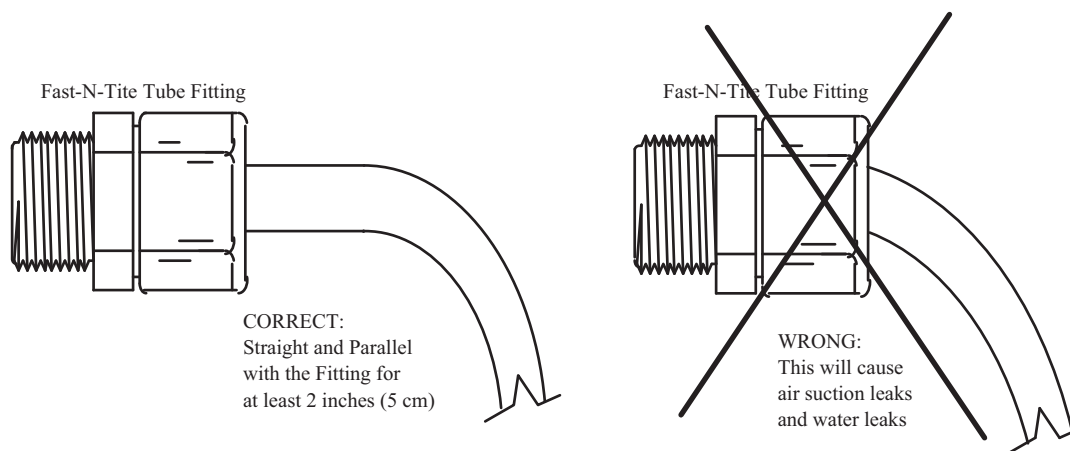

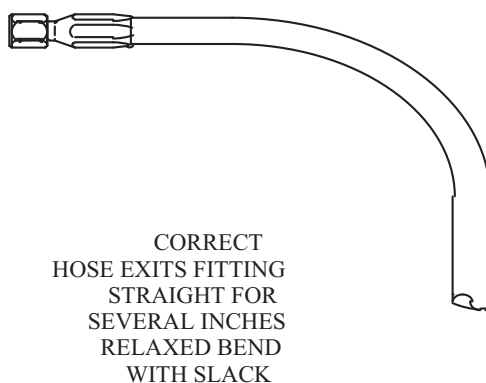
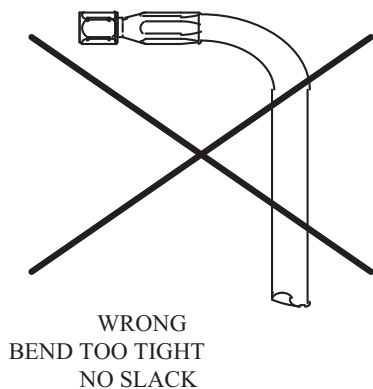

1. Connect all inlet feed lines with the supplied 20 feet (6 meters) of 1/2" (12.7 mm) I.D. Inlet Suction Hose:

Outlet of	to	Inlet of
Sea Cock Valve [2]		Sea Strainer [3]
Sea Strainer [3]		Inlet 3-Way Clean/Rinse Valve [30]
Inlet 3-way Clean/Rinse Valve [30]		Rinse/Clean bucket or container
Inlet 3-way Clean/Rinse Valve [30]		Booster Pump [4]
Booster Pump [4]		Fresh Water Flush Check Valve [26]
Fresh Water Flush Check Valve [26]		Plankton Filter [5]
Plankton Filter [5]		Prefilter [6]
Prefilter [6]		High Pressure Pump [11]

Tube Fitting Connections Assembly [24]

1. Cut tube end square and clean.
2. Loosen nut on fitting three turns.
3. Insert tube into fitting until it bottoms. Loosen nut completely and remove tube with attached parts from body. Check to ensure that the O-Ring is seated onto the tube under the spacer (and not pinched into the body). Insert tube with attached parts into the body and tighten nut finger tight.



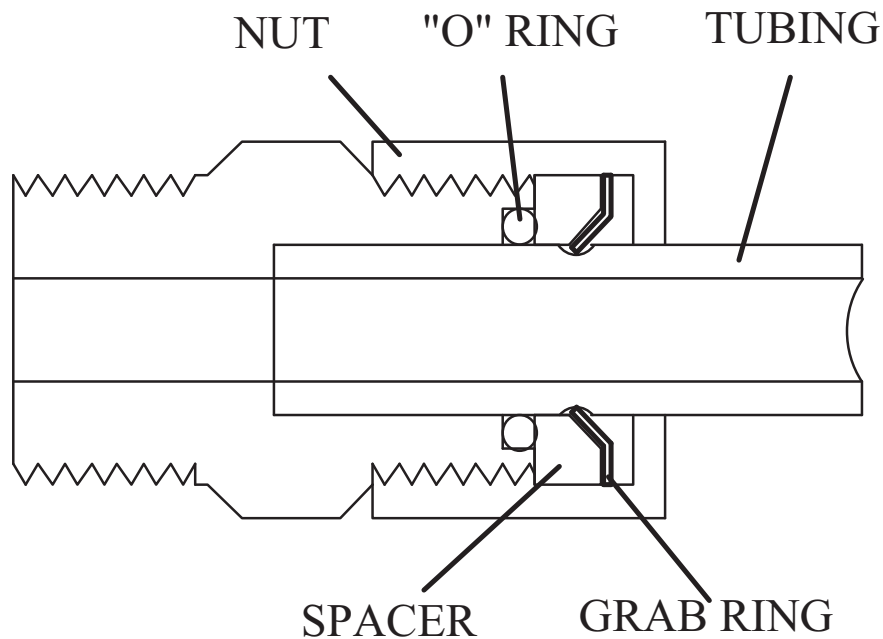

4. Connect Brine Discharge line with the supplied 20 feet (6 meters) of 3/8" (9.5 mm) O.D. Brine Discharge Tubing (refer to illustrations on the following page):

Outlet of	to	Inlet of
System Brine Discharge		Discharge 3-way Clean/Rinse Valve [31]
Discharge 3-way Clean/Rinse Valve [31]		Rinse/Clean Bucket or container
Discharge 3-way Clean/Rinse Valve [31]		Thru Hull Discharge fitting [18]

5. Connect Product Water line with the supplied 30 feet (9.14 meters) of 1/4" (6.35 mm) O.D. nylon tubing (refer to illustrations on the following page):

Outlet of	to	Inlet of
Potable Product Water from System		Charcoal Filter [22]
Charcoal Filter [22]		U.V. Sterilizer [23]
U.V. Sterilizer [23]		pH Neutralizing Filter
pH Neutralizing Filter		Boats Potable Water Storage Tank

UV Light Installation

The SP Series UV unit is shipped with the UV lamp, quartz sleeve, fittings, and O-rings and need to be assembled before the UV unit can be used.

1. Install the UV unit in a sheltered, well ventilated area.
2. Install the UV unit as close as possible to the point-of-use to avoid potential contamination discharge from pipes, fittings, etc.
3. The UV unit should be mounted on stable support to avoid straining or warping. Allow sufficient clearance around the unit for servicing.
4. Verify the location is free from vibration.
5. All UV units are rated for maximum operating pressure at 50psig (8.24 bar).

6. The UV unit must be properly grounded for safe and proper operation. Failure to properly ground the UV unit automatically voids all unit warranty.
7. Line voltage must be within 10.56V to 16.50V. Voltage outside the range will compromise the performance of the UV unit.

Plumbing Requirements

All piping, tubes and hoses leading to the UV unit connection points must be leak-free before the UV unit can be installed.



Note: The UV unit may be installed horizontally or vertically. For vertical installation, make sure the inlet port is positioned at the bottom.

Installation Procedure



Note: Do not assemble or install damaged parts. Quartz sleeve and UV lamp are fragile and must be handled with care.

Install Fittings

Perform this procedure to prepare the UV unit for installation.

1. Inspect each port and fitting to ensure threads are free of dirt, burrs, and excessive nicks. If threads are badly nicked, replace the fitting.
2. Wrap 1/4" wide PTFE tape 2 to 3 turns counter-clockwise around the male threads of the 1/4" fitting. Do not wrap tape around the first thread.
3. Screw the fitting into cylinder ports to finger tight position to achieve desired alignment.
4. Do not back-off fitting. Do not over-tighten fitting. Over-tightening could strip the fitting threads and cause leak.

Install Quartz Sleeve

Perform this procedure only when water piping for UV unit is in place and ready for service.

1. Visually inspect quartz sleeve for cracks and damages.
2. Remove the four screws holding the ballast box cover and remove the cover.
3. Remove the rubber boot and pull out the 4-point lamp connector.
4. Remove the compression nuts.
5. Insert the close-end of the quartz sleeve into the cylinder through the ballast box pass-thru.
6. Allowing 1/2" of the quartz sleeve to expose on the viewport pass-thru.
7. Lubricate the tips of the quartz sleeve with clean water and insert new O-ring. Ensure the O-ring has all-round contact with the cylinder pass-thru.
8. Tighten the compression nut while making sure the nut does not contact the quartz sleeve. Adjust O-ring position as necessary. The compression nut should be snug and tight, not over-torque.
9. Repeat Step 7 and 8 on the ballast box compression nut.

Connect Plumbing

Tube or hose ends must be cut squared and clean; must have no rough edges. The quick fit elbow fitting has a C-clamp that will lock the tube in place once inserted.

1. Insert the supply pipe into one cylinder port and label the port "Inlet".
2. Insert the temporary pipe into the other cylinder port to direct water into a container.
3. Slowly fill the cylinder with water and flush cylinder for 1 minute.
4. Remove temporary pipe and insert the return pipe into the cylinder port and label the port "Outlet".
5. Slowly pressurize the UV unit by filling the cylinder with water while checking for leaks.

6. If leaks are found on the compression nuts, depressurize the unit and slightly tighten the leaking compression nut.
7. Retest until a leak-free installation is verified.
8. Once UV unit is leak-free, the quartz sleeve installation is complete and the UV lamp can be installed.

 **Note:** To remove tube from fitting, first remove the C-clamp then push fitting sleeve down. Once the fitting sleeve is down, pull the tube out of the fitting.

Install Ultraviolet Lamp

Perform this procedure only after the quartz sleeve installation and leak-tests are completed successfully

1. Connect the UV lamp to the 4-point receptacle. If the lamp is not installed properly, lamp breakage will occur.
2. Insert lamp into quartz sleeve through compression nut pass-thru.
3. Install rubber boot over compression nut
4. Connect unit power cable to power source.
5. Tighten the 4 screws to secure ballast box cover.
6. Turn ON the power to the unit.
7. Verify UV lamp operation from the viewport.
8. Allow one minute for the UV lamp to warm up prior to flowing water through the UV unit.

 **Caution:** Use the viewport to verify the proper operation of the UV lamp.

 **Caution:** Rapid successive cycling of the power to the ballast can cause premature failure of the unit.

 **Caution:** Prior to energizing the lamp, make sure there is no water leaking from the quartz sleeve compression nuts.

Mounting the Unit

Once the UV unit is assembled and tested successfully, it can be mounted onto its permanent operational location. The unit must be mounted in a manner that will prevent excessive vibration and warping which will damage the quartz sleeve.

Operational Guidelines

1. Release the pressure in the UV treatment chamber before breaking the compression nut seals.
2. Disconnect all power to the UV unit before servicing.
3. Do not allow the inlet water temperature to drop below 35°F (2°C).
4. Do not allow the flow rate to exceed 2 GPM.
5. Do not cycle the UV unit more than 3 “ON/OFF” cycles in a 24-hour period.
6. Ensure all plumbing connections are tightly sealed before applying pressure.
7. Before connecting the return tube, flush the unit to rinse out any debris left from the installation process.

 **Danger:** UV LIGHT EXPOSURE CAN SEVERELY BURN AND DAMAGE EYES AND SKIN.

 **Danger:** DO NOT look at the blue UV light. DO NOT operate the UV lamp outside of the UV treatment chamber.

 **Caution:** The unit operates on high voltage and must be serviced by qualified personnel only.

 **Caution:** Standard flow rate are based on water temperature 35°F to 100°F. If the inlet water temperature exceeds 100°F (38°C), please contact your local CSR.



Caution: Cycling more than 3 cycles will reduce the end-of-life (EOL) output and/or cause premature lamp failure.

System Commissioning

INITIAL START-UP PROCEDURE OF A NEW Aqua Mini 170/350/550/750:

The Commissioning instructions must be carried out for initial start-up of a NEW system. Failure to follow these instructions exactly leads to system failure and causes damage to the components. Read this section and other appropriate sections of the manual in order to gain familiarity with the requirements of the system and functions of each component.

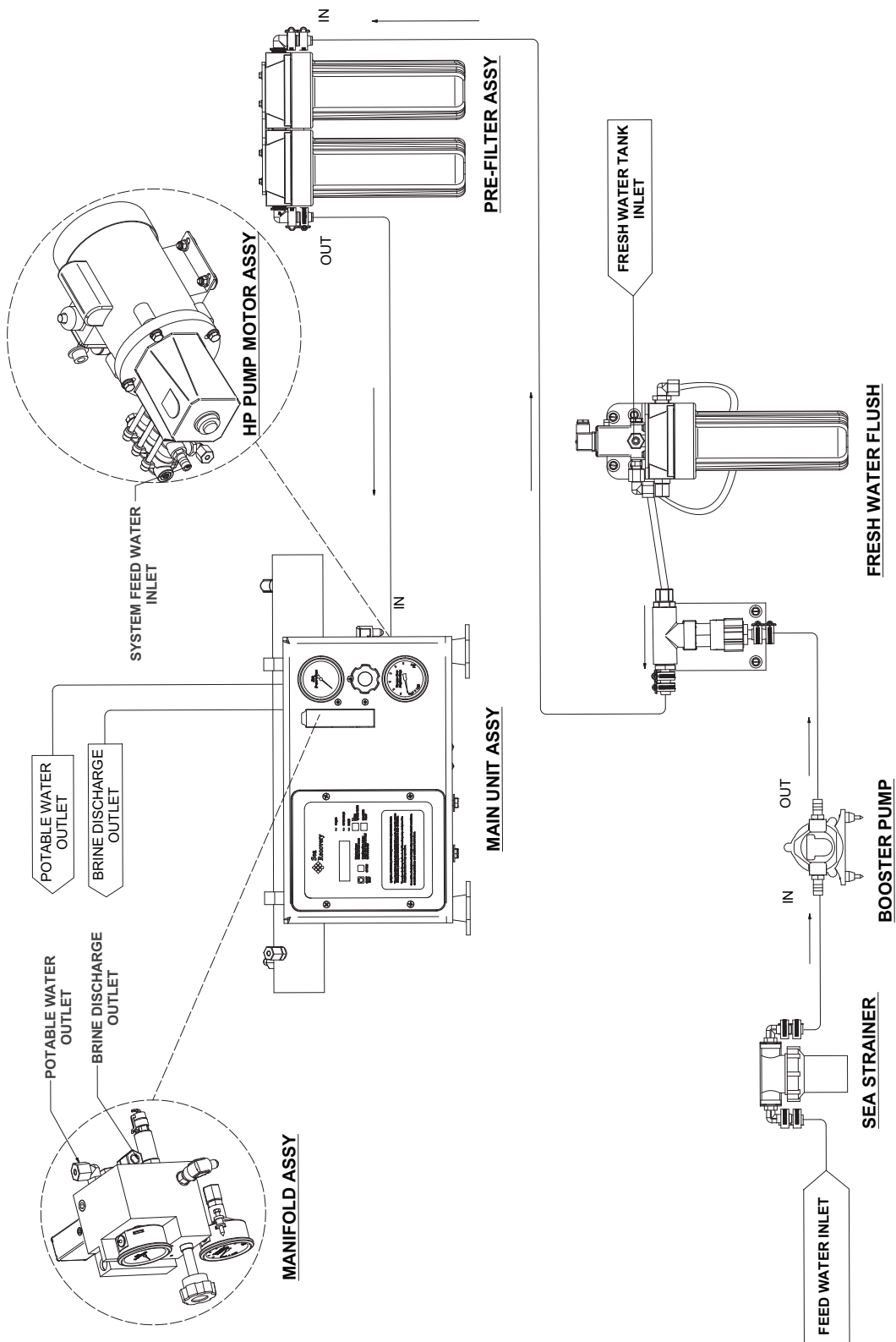

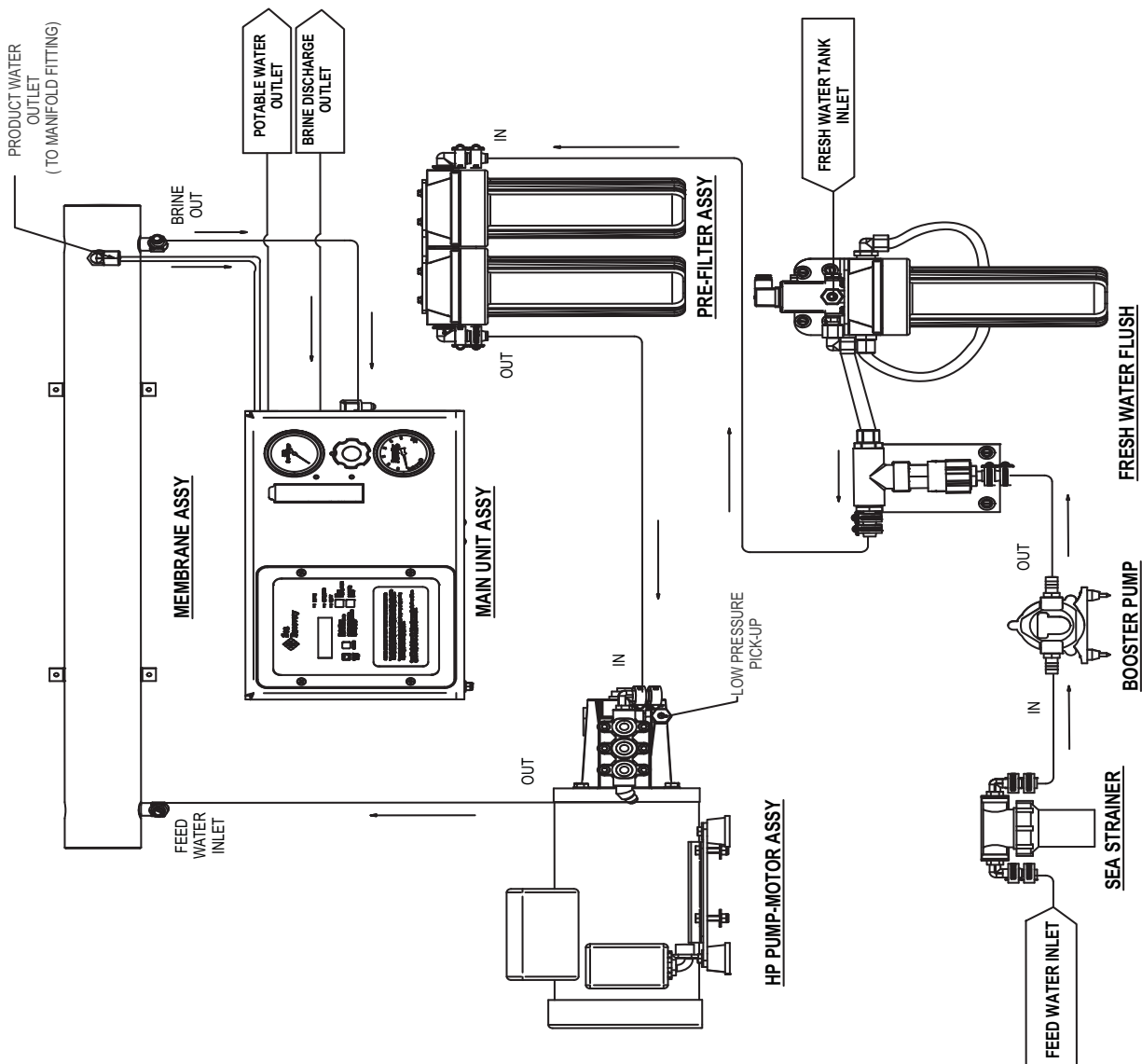
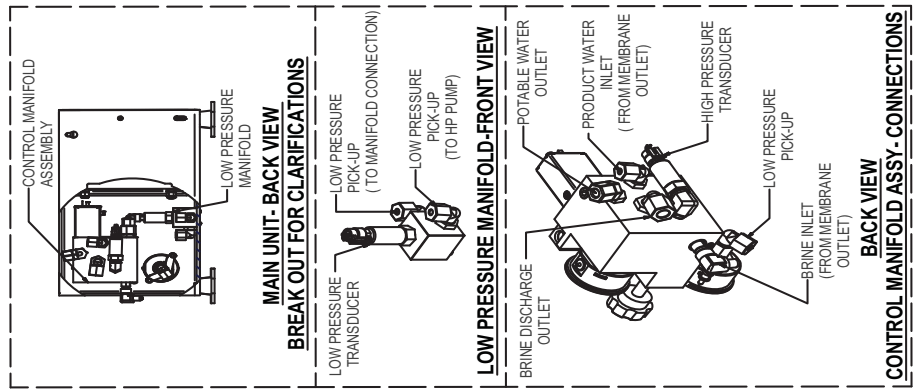

Start-up Procedure of a New Aqua Mini 170, 350, 550 & 750

1. Ensure that the installation has been properly performed as per the instructions in this section.
2. Ensure that the shipping tape from the High Pressure Pump Oil Fill Cap has been removed to expose the Oil Fill Cap air breather hole.

3. Ensure that the pump oil level is even with or higher than the center of the pump sight glass. Damage to the High Pressure Pump will occur if the wrong oil is used in its crankcase or if the oil level is not at minimum required level. Use only Sea Recovery supplied pump oil. The supplied Pump Oil is special hydraulic oil, which contains anti rust and wear inhibitors essential to the high-pressure pump crankcase section.
4. Ensure that the tube shipping plug has been removed from the Potable Water outlet port of the Water Control Manifold and that 1/4" product water tube is connected.
5. Reverse Osmosis Element:

 **Caution:** Some systems are shipped WITHOUT the Reverse Osmosis Membrane Element. This is to accommodate, for example, Boat Builders that install the system well in advance of commissioning the boat and the Aqua Mini 170 - 750.

If the Reverse Osmosis Membrane Element has been installed, there will be a Reverse Osmosis Membrane Element Serial Number tag, illustrated below, attached to the High Pressure Vessel. Find this Serial Number tag to ensure that the R.O. Membrane Element has been installed.

If the R.O. Membrane Element Serial Number tag is missing or does not contain a serial number and date, then immediately contact the company that sold the system to you, the installer, or Sea Recovery.

DO NOT attempt to operate the system without a Reverse Osmosis Membrane Element installed in the system otherwise extensive damage will result.



6. Check each tube connection to the system to ensure that the installer has properly connected and properly routed each tube. Improper routing and any blockage in any line causes damage to the system. **Do not rely on the installer's word; check it yourself.**
7. Make sure that the Electrical Power Source, boat's circuit breaker to the system, is switched "OFF".
8. Open the front panel of the Main Power Enclosure and check all electrical and electronic connections for proper wiring and attachment. Refer to the wiring diagrams in this section.
9. Close the Main Power Enclosure front panel.
10. Ensure that the manual By-Pass lever on the Diversion Valve [21] is positioned outward (away from the coil body).
11. Open any auxiliary valve within the incoming Feed Line, Outgoing Brine Discharge Line, and Outgoing Product Water Line.

 **Caution:** If any auxiliary valve is installed in these lines, it will damage the Aqua Mini if left closed during starting and/or operation of the system.

12. Open the Back Pressure Regulator Valve [17] FULLY OPEN by turning counter clockwise.

 **Caution:** The Back Pressure Regulator Valve [17] must be fully open when starting the Aqua Mini 170 - 750. If this valve is left closed, it will cause damage to the system.

13. Switch the Electrical Power Source, boat's circuit breaker to the system "ON".
14. HIGH PRESSURE ELECTRIC MOTOR ROTATIONAL CHECK:

Ask an assistant to view the fan section of the Booster Pump Motor [4] and High Pressure Pump Motor.[10] while you "Jog" the system.

Press the “Booster Pump” switch, and then immediately press the “Stop” switch. Ensure that the Booster Pump Electric Motor is turned in the proper rotation as indicated by an arrow on the front of the pump. If the motor is turned in the wrong direction, refer to the wiring diagrams in this section to correct. To change rotation in DC systems, reverse polarity to the respective electric motor.

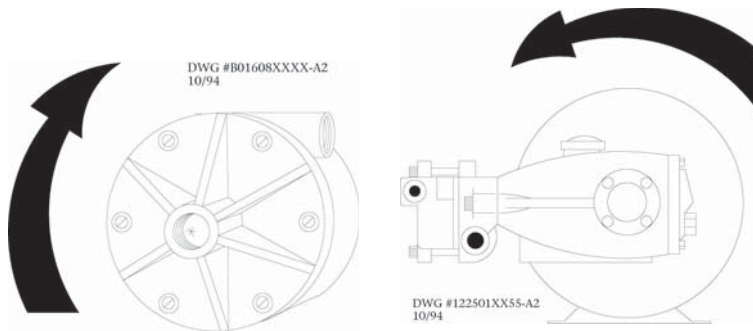

Press the “Start” switch, and then immediately press the “Stop” switch. Ensure that the High Pressure Pump Electric Motor is turned in the proper rotation. If the motor is turned in the wrong direction, refer to the wiring diagrams in this section to correct. To change rotation in DC systems, reverse polarity to the respective electric motor.

15. To start the system press the “Start” Switch or press the “Booster Pump” Switch and then the “Start” switch. If the system automatically shuts off after several seconds of operation, this may be due to a system fault. Look at the Touch Pad to confirm whether a fault has occurred. If the “High/Low Pressure” Fault Lamp is illuminated, ensure that the System Feed Line is primed and that there is no air in the Feed Water Line. Press the Fault Reset button on the Touch Pad and restart the system. Initial New System Commissioning will require priming of the Feed Water through the prefiltration section in order to build sufficient feed water pressure to maintain operation.
16. After 5 minutes of running un-pressurized, slowly adjust the Back Pressure Regulator Valve [17] by turning clockwise to increase the pressure to the proper setting (example: Approximately 850 psi for 35,000 ppm seawater @ 77 F).

WHILE ADJUSTING THE BACK PRESSURE REGULATOR TO OPERATING PRESSURE, OBSERVE THE PRODUCT WATER FLOW METER.

DO NOT EXCEED 7 GALLONS PER HOUR ON THE AQUA MINI 170 SYSTEM

DO NOT EXCEED 14.5 GALLONS PER HOUR ON THE AQUA MINI 350 SYSTEM.

DO NOT EXCEED 23 GALLONS PER HOUR ON THE AQUA MINI 550 SYSTEM.

DO NOT EXCEED 31.3 GALLONS PER HOUR ON THE AQUA MINI 750 SYSTEM.

DO NOT EXCEED 900 PSI ON HIGH PRESSURE GAUGE.

17. If any abnormality develops, stop the system and correct the problem.
18. Although the system is producing “product water”, the “product water” may not be “potable” for up to 30 minutes. The salinity of the Product Water diminishes gradually, until it reaches the factory setting at which time it is directed to the “potable” (good water) position and into the Post Filtration components onward to the Ship’s Storage Tank [24]. At the same time, the Water Quality LED on the Touch Pad changes from red to green.
19. Check for:
 - A constant feed water flow.
 - A consistent system pressure.
 - Leaks in the system.
 - Abnormal noises or other occurrences.

Chapter 5

System Operation

System Operation Notes

The fresh water production of the Aqua Mini 170, 350, 550, & 750 depends on six factors:

- Feed Water Temperature
- Feed Water Salinity
- Feed Water Flow Rate
- Operating Pressure
- Characteristics of the individual R.O. Membrane Element
- Condition of the individual R.O. Membrane Element

Feed water temperature and salinity vary depending upon location of operation.

Feed water flow is fixed on the Aqua Mini 170 at .5 gallon per minute / 1.89 liters per minute; and on the Aqua Mini 350 at 1.5 gallons per minute / 5.68 liters per minute; Aqua Mini 550/750 at 3.5 gallon per minute / 13.25 liters per minute by design.

The only operator adjustment that remains is the operating pressure, which is adjusted at startup by the operator. There are two parameters, which are controlled by this single operator adjustment: Operating Pressure and resulting Product Water Flow.

The Operating Pressure is adjusted upward until the Aqua Mini 170 system produces 7 gallons per hour / 26.8 liters per hour; the Aqua Mini 350 System produces 14.6 gallons per hour / 55.2 liters per hour; Aqua Mini 550 System produces 23 gallons per hour / 87 liters per hour; Aqua Mini 750 System produces 31.25 gallons per hour / 118.3 liters per hour. However, the maximum Operating Pressure allowed is 900 psi. Do not exceed 900 psi even though the system does not produce the specified amount of product water. The system automatically shuts down if the maximum Operating Pressure exceeds 950 psi.

External factors, such as Feed Water Temperature, Feed Water Salinity, or condition of the R.O. Membrane Element may cause the system to produce less than specified even though the Operating Pressure is at 900 psi.

Operation Cautions

- Open all valves on the piping or hoses leading to and from the system.
- Check the Oil level in the High Pressure Pump.
- Check for any abnormalities such as leaks, damaged hoses, wires, and etc.

Startup Procedure

1. Open the Cock Valve [2] fully.
2. Switch the electrical power to the system on at the circuit breaker. The "POWER" lamp on the system Touch Pad will illuminate.
3. Ensure that the back-pressure regulator valve [17] is fully open (counterclockwise). This is not required and is commonly skipped on systems equipped with a Remote Control. Performing this step reduces wear and tear on the mechanical and electrical components.
4. Press the "Start" switch. This initiates the automatic start sequence. The automatic start sequence begins with the booster pump starting immediately and the high-pressure pump following after a brief delay.

or

Press the “Booster Pump” switch then press “Start” switch. Pressing the booster pump switch starts just the booster pump. It continues running by itself until the start switch is pressed.

High/Low Pressure Fault Lamp Explanation

Low Pressure fault: When the inlet pressure to the high-pressure pump falls below 6 psi, the “High/Low Pressure” lamp blinks. If the condition is not corrected, the system shuts down after 20 seconds. The Low Pressure switch monitors this condition caused by a dirty pre-filter, a closed Inlet Sea Cock Valve, or restriction at the Inlet Thru-Hull fitting or in the inlet feed line.

High Pressure fault: The High Pressure switch stops the system if pressure exceeds 950 psi.

1. After the cause of the fault condition has been corrected, press “Fault Reset” and repeat the steps in [Startup Procedure](#) on page 41.
2. Slowly adjust the backpressure regulator [17] until the system produces the specified product water gallon per hour flow at the Product Flow meter, but do not exceed 900 psi.

See “Temperature Effects Chart” and “Salinity Effects Chart” for expected pressure settings and production.

Colder Water: At sea water temperatures below 77 F, the Aqua Mini must operate at a higher pressure to produce the specified amount of fresh water. As water temperature drops, the individual H₂O molecules are less active and higher pressure is required to drive them through the membrane surface. Another result of lower temperature feed water is that the fresh water produced has a lower salt content. Do not operate with feed water below 33 F / 1 C because the product water will freeze and cause mechanical failure and rupture of components within the system.

Warmer Water: At water temperatures above 77 F, the Aqua Mini operates at a lower pressure to produce the specified amount of fresh water. As water temperature rises, the individual H₂O molecules are more active and pass through the R.O. Membrane Element with less pressure. Higher temperatures also allow more salt to make its way into the fresh water. Do not operate with feed water that exceeds 122 F / 50 C. High temperatures will cause structural damage to the R.O Membrane Element.

3. If any abnormality develops, stop the system and correct the problem.
4. Check for unusual noises or other occurrences.

Sea Recovery Mini Controller Operations

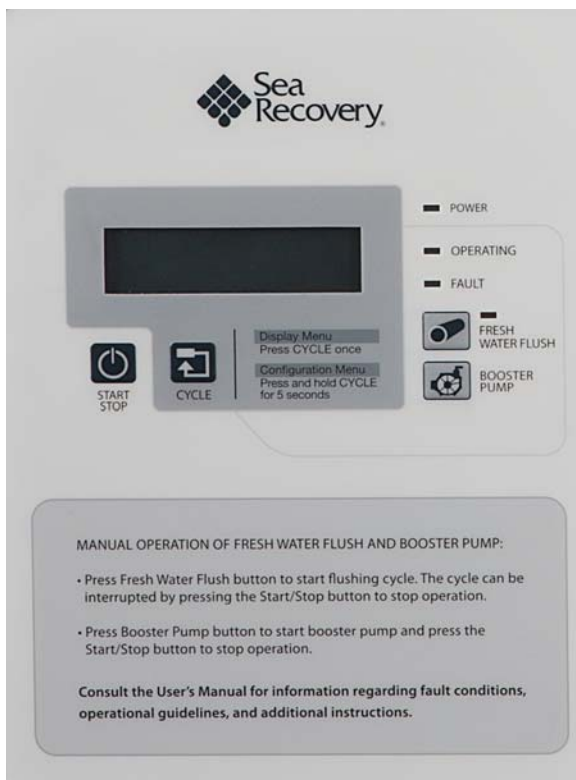

Start/Stop button

1. Powers on and sets the system in its initial state.
2. When the system is producing water and the START/STOP button is pushed, the system stops all pumps and diverts water into the sea.
3. Resets all faults.

Note that this button performs its designated action, regardless of whether or not you are browsing a menu.

Cycle button

This button allows the operator to cycle through the process and configuration parameters.

- Press the CYCLE button once to view to view the Display Menu.
- Press and hold CYCLE for 5 seconds to view the Configuration Menu.

Display Menu

This menu monitors measured values (e.g. pressure, flow and salinity); system states (e.g. FWF, running, FWP); and timers. Press the CYCLE button once to view this menu and CYCLE again to scroll through the menu items. Every time CYCLE is pressed, the next item is shown. If you release, and do not push the CYCLE button for more than 5 seconds, you will return to the main screen.

1. Pre-Filter Press – Inlet pressure in Bar or PSI (pre-filter inlet)
2. HP Inlet Press – Inlet pressure in Bar or PSI (high pressure pump inlet)
3. Membrane Press – Membrane pressure in Bar or PSI
4. Product Flow – Product water flow in l/min or GPM
5. Brine Flow – Brine flow in l/min or GPM
6. Water Quality – Salinity (water status) in ppm
7. Total Hours – High pressure pump/ETD hour meter (counted in seconds but shown in whole hours)
8. Tank Full – Yes or no

-
9. Tank Empty – Yes or no
 10. Booster Relay - Booster pump on or off
 11. FWF Relay – Fresh Water Flush on or off
 12. HP Relay – High pressure pump on or off
 13. DV Relay – Diversion valve on or off
 14. UV Relay – Ultraviolet on or off
 15. Supply Voltage – volts (used only for diagnostics)
 16. Version – software version

Configuration (Change) Menu

This menu shows a list of configuration parameters that can be changed by the operator. Press the CYCLE button and hold for 5 seconds to view this menu and CYCLE again to scroll through the menu items. Every time CYCLE is pressed, the next item is shown. Holding the CYCLE button for more than 5 seconds selects the displayed menu item. Note that this menu does not allow the operator to monitor the state of these configuration parameters. Please use the Configuration (Read) Menu to do so.

1. Unit – units (metric or US)
2. Low Pressure 1 Inst – S1 Lo pressure sensor installed (yes or no)
3. Low Press 2 Inst – S2 Lo pressure sensor installed (yes or no)
4. Prod Flow Inst – Product flow meter installed (yes or no)
5. Brine Flow Inst – Brine flow meter installed (yes or no)
6. Tank Full Inst – Tank level full sensor installed (yes or no)
7. Tank Empty Inst – Tank level empty sensor installed (yes or no)
8. FWF Delay – High pressure pump stop to FWF delay (HH:mm:ss)
9. Time to AutoShut – Auto shutdown after X hours in state FWP (HH:mm:ss)
10. AutoShut Time – Auto shutdown after time (yes or no)
11. AutoShut Tank – Auto shutdown on tank full (yes or no)
12. FWF Duration – FWF duration time (HH:mm:ss)
13. FWF Interval – FWF interval time (HH:mm:ss)
14. PassiveUVoff – Time from leaving fresh water production to turning UV off (HH:mm:ss)
15. UV off delay – Time from UV on to diversion valve to tank (HH:mm:ss)
16. AutoStart Tank – Autostart on tank empty (yes or no)
17. BP Delay – Time from feed pump to high pressure pump/ETD (HH:mm:ss)
18. Salinity Level – Salinity error level (ppm)
19. Min Pressure – minimum pressure (Bar or PSI)
20. Min Pressure Time – Min pressure measure time (HH:mm:ss)
21. Max Pressure – Maximum pressure (Bar or PSI)
22. Sol. Valve Time – Solenoid valve time (seconds)

Configuration (Read) Menu

This menu monitors a selected list of configuration parameters, which may be of interest to the operator (e.g. units are metric or US, FWF time interval, etc.). This menu is appended to the Display Menu.

1. Unit – units (metric or US)
2. Low Pressure 1 Inst – S1 Lo pressure sensor installed (yes or no)
3. Low Press 2 Inst – S2 Lo pressure sensor installed (yes or no)
4. Prod Flow Inst – Product flow meter installed (yes or no)
5. Brine Flow Inst – Brine flow meter installed (yes or no)
6. Tank Full Inst – Tank level full sensor installed (yes or no)
7. Tank Empty Inst – Tank level empty sensor installed (yes or no)
8. Time to AutoShut – Auto shutdown after X hours in state FWP (HH:mm:ss)
9. AutoShut Time – Auto shutdown after time (yes or no)
10. AutoShut Tank – Auto shutdown on tank full (yes or no)
11. FWF Duration – FWF duration time (HH:mm:ss)

12. FWF Interval – FWF interval time (HH:mm:ss)
13. AutoStart Tank – Autostart on tank empty (yes or no)
14. Salinity Level – Salinity error level (ppm)
15. Min Pressure – minimum pressure (Bar or PSI)
16. Max Pressure – Maximum pressure (Bar or PSI)
17. Sol. Valve Time – Solenoid valve time (seconds)

Fresh Water Flush button

This button initiates the Fresh Water Flush (FWF) cycle. The cycle can be interrupted by pressing this button again to stop operation. Note that this button starts the FWF cycle, regardless of whether or not you are browsing a menu.

Booster Pump button

Start the booster pump. Press the Start/Stop button to stop operation. Note that this button starts the booster pump, regardless of whether or not you are browsing a menu.

Chapter 6

System Storage and Cleaning

R.O Membrane Element Handling and System Storage Cautions

1. **TEMPERATURE:** Never store the R.O. Membrane Element or Membrane/Vessel Assembly in direct sunlight. Never expose the R.O. Membrane Element or Membrane/Vessel Assembly to storage temperatures above 120 F / 50 C or below 32 F / 0 C. High temperatures cause up to 40% loss of production from the R.O. membrane element. This damage is irreversible. Freezing temperatures cause mechanical damage to the system and irreversible damage to the R.O. membrane element.
2. **DRYING OUT:** Never allow the R.O. membrane element to dry out, as 40% production loss occurs. This membrane damage may be irreversible. Some, but not all, production may be restored by saturating the R.O. Membrane Element in product water for several days and then operating the system using product water feed into the system for a continuous 48 hour period. The R.O. membrane element must remain wet at all times.
3. **BIOLOGICAL FOULING:** Protect the R.O. membrane element from biological fouling. Production loss occurs if the element becomes fouled by biological slimes. Some, but not all, production may be restored after cleaning.
4. **CHEMICAL FOULING:** Never expose the R.O. Membrane Element to chemicals other than those supplied by SRC. Use caution when operating the system in harbors that may be polluted with chemicals, oil, or fuel. Chemicals may damage the R.O. Membrane Element beyond repair.
5. **STORAGE:** The dark and moist interior of a membrane element is an excellent breeding ground for microorganisms. Simply operating the system does not protect the R.O. Membrane Element from up to 40% production loss due to biological fouling. During short-term shutdowns, the system must be rinsed as explained in the following pages. During long-term shutdowns, the system must be rinsed as well as chemically treated as explained later in this chapter.
6. **NEW SYSTEM STORAGE:** If you are storing the system for longer than 3 months, do not install the membrane. Install the membrane prior to actual use. If storage of the new system is longer than 3 months, the system must be rinsed with fresh water and stored with fresh storage solution every 3 months, otherwise biological fouling and/or drying out damages the R.O. Membrane Element.

On the following page are two illustrations that show the flow of water in a Once-Through-Rinse operation and in a Closed Loop operation. These illustrations may be referred to during the Rinse, Clean, and Storage procedures.

CLEAN RINSE OPERATION
ONCE THROUGH CONFIGURATION

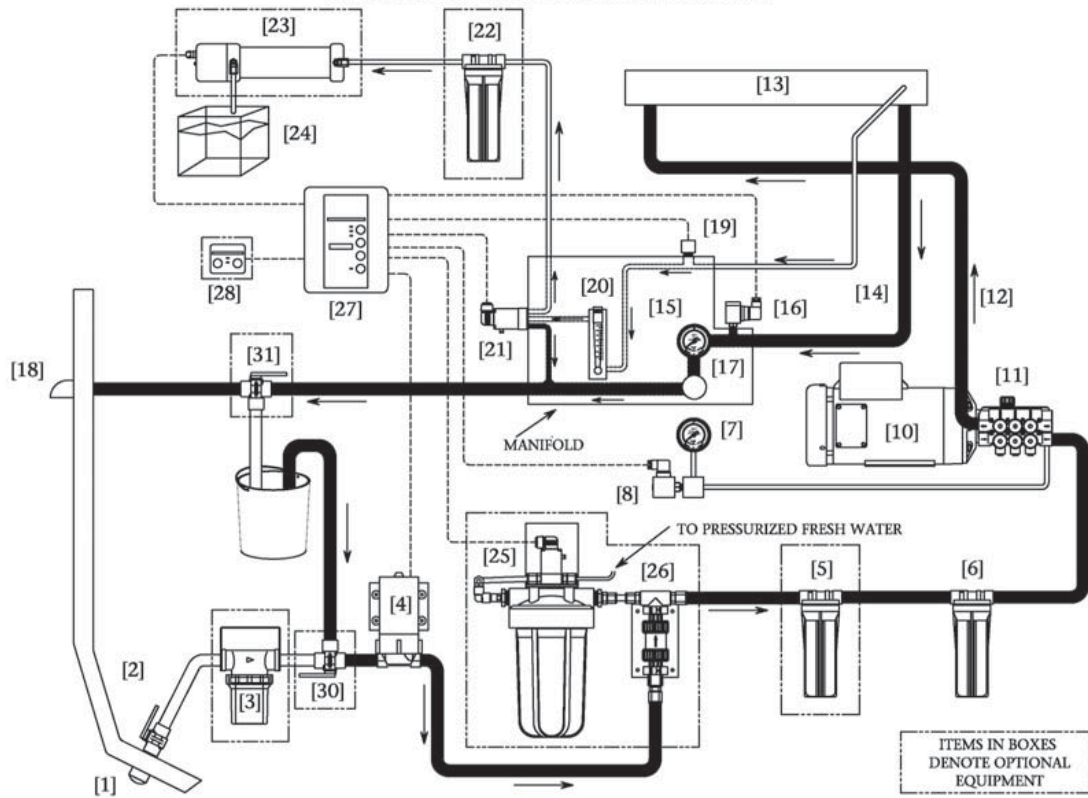

This is used to Rinse the System with Fresh Water, and also to Discharge the contents of the cleaning solution bucket.

Clean Rinse Operation
Closed Loop Configuration

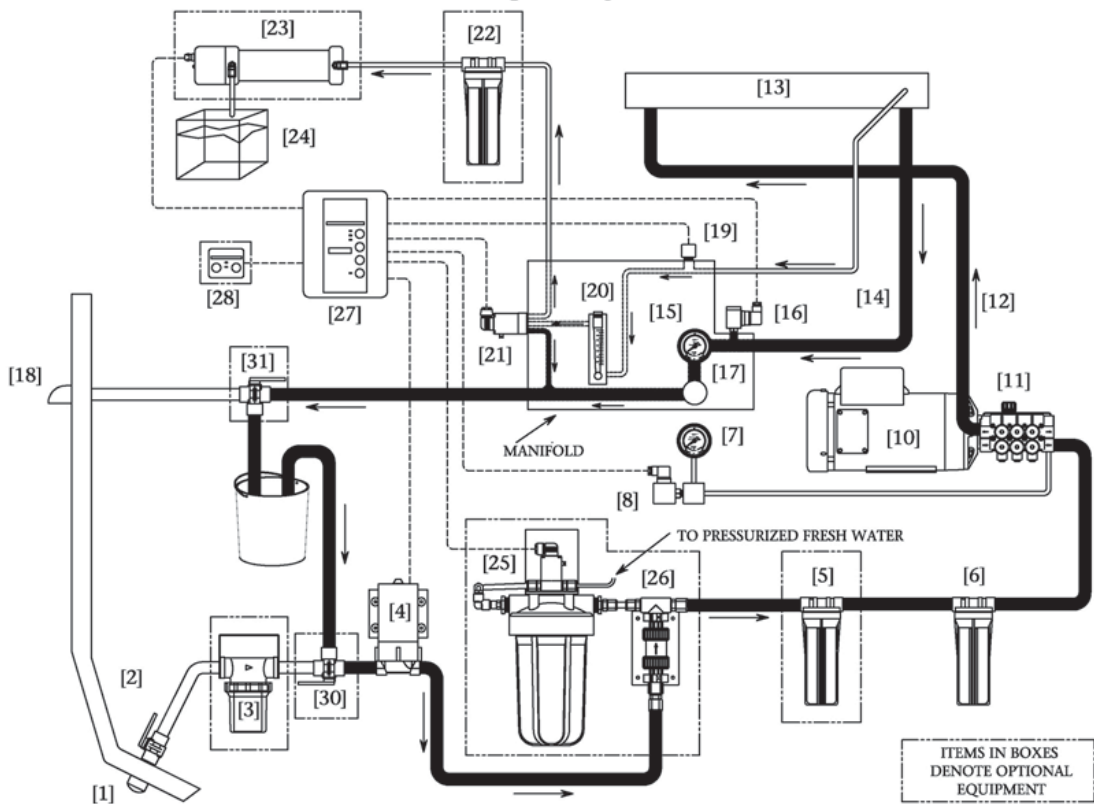

This is used to Circulate Cleaning or Storage Solution through the system.

SIMPLIFIED VERSION OF
ONCE THROUGH RINSE

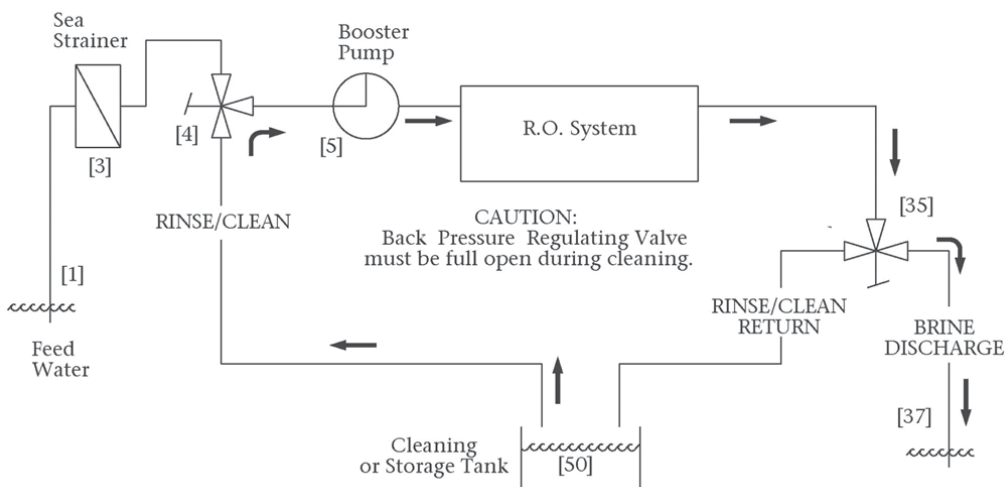

This illustration demonstrates a Once Through Rinse Configuration

SIMPLIFIED VERSION OF
MEMBRANE RECIRCULATING CLEANING LOOP

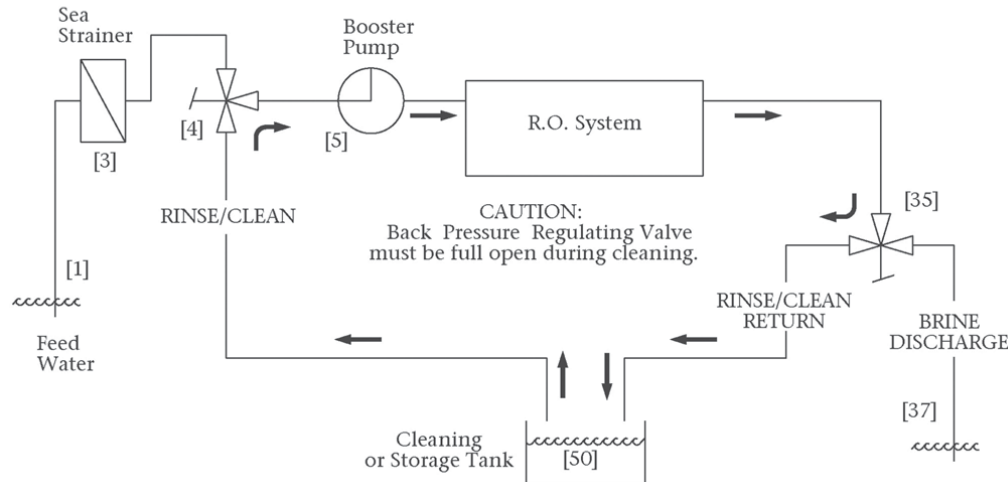

This Illustration demonstrates a Closed Loop Configuration

When the instructions within this section state "configure for Once Through Rinse" proceed as follows

1. Configure the Suction line for a Once Through Configuration as illustrated in the drawings at the TOP of pages 4 and 5 of this section. Disconnect the outlet line from the Sea Strainer [3] and place it in the container or bucket. Or if the system is equipped with an Optional Inlet Clean/Rinse 3-way ball valve [30] between the Sea Strainer [3] and Booster Pump [4], then position this valve to draw from the bucket.
2. Configure the Brine Discharge line for a Once Through Configuration. Connect the Brine Discharge Line from the system to the Thru-Hull over board discharge fitting [18], normal connection for normal operation. Or if the system is equipped with an Optional Discharge Clean/Rinse 3-way ball valve [31] between the System and the Thru-Hull over board discharge fitting [18], then position this valve to discharge through the Thru-Hull fitting, normal connection for normal operation

When the instructions within this section state "configure for Closed Loop" proceed as follows

1. Configure the Suction line for a Closed Loop Configuration as illustrated in the drawings at the BOTTOM of pages 4 and 5 of this section. Disconnect the outlet line from the Sea Strainer [3] and place it in the container or bucket. Or if the system is equipped with an Optional Inlet Clean/Rinse 3-way ball valve [30] between the Sea Strainer [3] and Booster Pump [4], then position this valve to draw from the bucket.
2. Configure the Brine Discharge line for a Closed Loop Configuration. Disconnect the Brine Discharge Line from the Thru-Hull over board discharge fitting [18] and place it in the container or bucket. Or if the system is equipped with an Optional Discharge Clean/Rinse 3-way ball valve [31] between the system and the Thru-Hull over board discharge fitting [18], then position this valve to return to the container or bucket.

Short Term Shutdown

A short-term shutdown is defined as a period of time in which the system is not utilized for up to four weeks. An effective short-term protection for the system and R.O. membrane element is a Fresh Water Rinse of the entire system with fresh water (product water from the system). This prolongs the system life by minimizing electrolysis and retarding biological growth.

- ✔ **Note:** If the system is equipped with an automatic Fresh Water Flush Accessory then it is not necessary to read this section. The Automatic Fresh Water Flush accessory rinses the system every 7 days automatically as described previously. However, see "Winterizing and Freezing" note below.

WINTERIZING AND FREEZING TEMPERATURE STORAGE NOTE: If the system is exposed to freezing temperatures, DO NOT activate the Automatic Fresh Water Flush. Instead, perform a Manual Fresh Water Rinse

as described below. Deactivate the Automatic Fresh Water Flush cycle by pressing the “Stop” switch twice (2 times).

MANUAL FRESH WATER RINSE PROCEDURE: Follow the directions below if the system is not equipped with an Automatic Fresh Water Flush accessory. This procedure displaces the system feed water with fresh water and allows a short-term shutdown for up to four weeks. Five gallons (19 liters) of fresh product or potable water is required for the fresh water rinse.

1. Close the Cock Valve [2].
2. Fill a 5-gallon container with clean, fresh water.
3. Configure the system for a Once Through Rinse.
4. Fully open the Back Pressure Regulating Valve [17] counter clockwise.
5. Press the “Start” switch. The fresh water rinses the system and discharges out to waste [18].
6. Apply 200 psi of pressure to the system by turning the Back Pressure Regulator [17] clockwise. This allows the system to produce a minimal amount of product water, which ensures that the product water line remains wet.
7. Just prior to depleting the rinse water from the bucket, fully open the Back Pressure Regulator Valve [17] counter clockwise and stop the system.

IN NON FREEZING TEMPERATURES, THE SYSTEM MAY NOW BE LEFT UNATTENDED FOR SEVERAL WEEKS. HOWEVER, IF THE SYSTEM WILL BE EXPOSED TO FREEZING TEMPERATURES, CONTINUE WITH THE FOLLOWING PROCEDURES:

8. Again, fill a 5-gallon container with clean, fresh water. Add twenty percent (1 gallon / 4 liters) food grade glycerin (propylene glycol) to the Storage Chemical Solution. This prevents the water in the system from freezing.
9. Configure the system for a Once Through Rinse.
10. Fully open the Back Pressure Regulating Valve [17] counter clockwise.
11. Press the “Start” switch. The fresh water rinses the system and discharges out to waste [18].
12. Just prior to depleting the rinse water from the bucket, fully open the Back Pressure Regulator Valve [17] counter clockwise and stop the system. Deactivate the Automatic Fresh Water Flush Cycle by pressing the “Stop” switch twice (2 times).
13. Reconfigure the system for normal operation by reconnecting the Sea Strainer [3] outlet line, or reposition the Inlet Rinse/Clean 3-way ball valve [30] to normal operation position. The system is now exposed to fresh rinse water and may be left unattended for up to four weeks.
14. Remove product water from the Post Filtration Section
 - a) Open the Charcoal Filter Bowl and drain the product water from it.
 - b) Disconnect the bottom tube fitting from the Ultra Violet Sterilizer and drain the product water from it.
 - c) Open the pH Neutralizer Filter Bowl and drain the product water from it.
 - d) Disconnect or Close the valve from the fresh water tank to the Automatic Fresh Water Flush and drain the Fresh Water Flush Charcoal Filter bowl.

The Manual Fresh Water Rinse Procedure should be repeated every four weeks if the system is not in use and if the system does not have the Optional Automatic Fresh Water Flush.

Long Term Shutdown

Long Term or Prolonged Shutdown is a period in which the system goes un-used for longer than three months, depending on conditions. For this interval, the system should first be rinsed with fresh water then stored with system and Membrane Element Storage Chemical (SRC SC). This chemical inhibits bacterial growth while maintaining the high flux and salt rejection of the R.O. Membrane Element. The Long Term Shutdown procedure requires 10 gallons (38 liters) of potable water. Follow the directions listed below.

WINTERIZING AND FREEZING TEMPERATURE STORAGE NOTE: If the system is exposed to freezing temperatures, add twenty percent (1 gallon / 4 liters) food grade glycerin (propylene glycol) to the Storage Chemical Solution. This prevents the water in the system from freezing.

1. Close the Cock Valve [2].
2. Replace the Pre-filtration Cartridges [6] with new Sea Recovery Pre-filtration Elements.
3. Fill a clean 5-gallon container with non-chlorinated product water.

4. Configure the system for a Once Through Rinse.
5. Fully open the Back Pressure Regulating Valve [17] counter clockwise.
6. Press the "Start" switch. The fresh water rinses the system and discharges out to waste [18].
7. Apply 200 psi of pressure to the system by turning the Back Pressure Regulator [17] clockwise. This allows the system to produce a minimal amount of product water, which ensures that the product water line remains wet.
8. Just prior to depleting the rinse water from the bucket, fully open the Back Pressure Regulator Valve [17] counter clockwise and stop the system (press stop button twice to abort Fresh Water Flush Cycle).
9. Fully open the Back Pressure Regulating Valve [17] counter clockwise.
10. Fill the 5-gallon bucket with product water. Add 4 ounces (1/6th bottle) of SRC SC Storage Chemical to the water in the plastic bucket. **DO NOT ADD ANY OTHER CHEMICAL.**
11. Mix and thoroughly dissolve the solution in the container.
12. If the system will be exposed to freezing temperatures, add 1 gallon (4 liters) food grade glycerin (propylene glycol) to the 5 gallons of Storage Solution. This prevents the water in the system from freezing. **DO NOT ADD ANY OTHER CHEMICAL.**
13. Configure the system for a **Closed Loop Configuration.**
14. Operate the system by pressing the "Start" Switch. The Storage Chemical Solution flows from the container through the system and back into the container in a Closed Loop configuration. **Do not pressurize the system; leave the Back Pressure Regulator [17] fully open.**
15. After approximately 10 minutes of circulation, stop the system (Press stop button twice to abort Fresh Water Flush Cycle).
16. Configure the system for a **Once Through Rinse.**
17. Start the system, which discharges the Storage Chemical Mixture through the Brine Discharge Thru Hull Fitting [18].
18. Stop the system just before depleting the Storage Chemical Solution from the tank. Press the Stop switch twice to abort the Automatic Fresh Water Flush cycle.
19. Reconfigure the system for normal operation by reconnecting the Sea Strainer [3] outlet line for normal operation. Or if the system is equipped with a Inlet Clean/Rinse 3-way ball valve [30] then position this valve to the normal operating position towards the Sea Strainer.
20. **WINTERIZING AND FREEZING TEMPERATURE STORAGE NOTE:** If the system is exposed to freezing temperatures, remove product water from the Post Filtration Section.
 - a) Open the Charcoal Filter Bowl and drain the product water from it.
 - b) Disconnect the bottom tube fitting from the Ultra Violet Sterilizer and drain the product water from it.
 - c) Open the pH Neutralizer Filter Bowl and drain the product water from it.
 - d) Disconnect or Close the valve from the fresh water tank to the Automatic Fresh Water Flush and drain the Fresh Water Flush Charcoal Filter bowl.

The system may now be left unattended for up to 3 to 6 months. With ideal conditions including a relatively new R.O. Membrane Element, a clean system prior to storage, cool temperatures, and no leakage of storage chemical within the system, it provides protection for up to 6 months. Adverse conditions may provide less protection. Evaluate these factors before determining the proper interval between repeated rinsing and storage periods.

R.O. Membrane Element Cleaning Procedures

Do not arbitrarily clean the R.O. Membrane in a NEW system. If a New system experiences low production or high salinity then it should be operated for up to 48 hours continuously to clear and saturate the R.O. Membrane Element and product water channel. If a new system still experiences low production and or high salinity after 48 hours of continual operation, then contact the factory.

The membrane element requires cleaning from time to time. Biological growth and salt accumulation eventually make replacement necessary. The frequency of required cleaning depends on the amount of production loss and salt rejection loss resulting from normal use. In order to properly assess performance changes, it is important to maintain daily log readings for comparison.

During performance comparisons, Feed Water Temp, Feed Water Salinity, and System Operating Pressure must be taken into consideration and compensated for. After compensations, a 10% decline in productivity (GPH Flow) and/or a 10% increase in salt passage indicate that the R.O. Membrane Element may require cleaning.

If production rate has dropped dramatically since the last time the system was used, this may be due to drying out of the R.O. Membrane Element and/or fouling during storage. If the system has not been used for several months and the production rate has dropped dramatically since the last time used, try operating the system for 48 or more continuous hours to saturate the Product Water Channel within the R.O. Membrane Element.

If production rate drops dramatically from one day to another, this may be due to chemical attack which is not cleanable. Sewage chemicals or petroleum products cause irreparable damage to the R.O. Membrane Element. Suspended solids fouling results from silt, coral dust, river or inland waterway debris, or other small solid matter.

R.O. Membrane Element Cleaning Water and Chemical Requirements

1. The system must be rinsed with fresh water before any cleaning procedure.
2. The process of rinsing and cleaning the R.O. Membrane Elements requires 20 gallons / 76 liters of fresh non-chlorinated product water.
3. The Sea Recovery Reverse Osmosis cleaning compounds are designed to clean in a closed loop configuration moderate fouling from the R.O. membrane element. If the R.O. Membrane Element is excessively fouled and in-field cleaning is not successful, the R.O. Membrane Element may be returned to Sea Recovery or to one of Sea Recovery's many Service Dealers for professional chemical cleaning. If your membrane requires professional cleaning, please contact Sea Recovery for a Return Authorization Number, price quotation, and return instructions.
4. SRC MCC-1, Membrane Cleaning Compound "# 1" is an alkaline cleaner designed to clean biological fouling and slight oil fouling from the R.O. Membrane Element. Biological fouling is usually the first cause of the R.O. Membrane Element fouling. The system is constantly exposed to seawater and biological growth occurs from the first day forward. If exposed to seawater and left to sit, the R.O. Membrane Element becomes fouled even with no actual system use. This fouling is minimized with fresh water rinsing whenever the system is not in use.
5. SRC MCC-2, Membrane Cleaning Compound "# 2" is an acid cleaner designed to clean calcium carbonate and other mineral deposits from the R.O. Membrane Element. Mineral fouling is a slow process, which takes place during use of the system. Therefore, if the system has relatively few hours of use yet shows signs of R.O. Membrane Element fouling then that fouling is likely biological fouling. If the system has in excess of 1000 hours of use then there may be some mineral fouling combined with biological fouling.
6. SRC MCC-3, Membrane Cleaning Compound "# 3" is used for iron fouling. It is not included in the SRC Membrane Cleaning Chemical kit. If the system's R.O. membrane element is fouled with rust from iron piping, then SRC CC-3 may be used for effective removal of light or moderate rust fouling. Heavily rust fouled RO Membranes may not be recoverable as rust not only fouls the Membrane Element but also damages the membrane surface.



Caution: CAUTION: DO NOT MIX DIFFERENT CLEANING CHEMICALS TOGETHER.

DO NOT USE DIFFERENT CLEANING CHEMICALS TOGETHER AT THE SAME TIME. MIX THE CLEANING CHEMICALS SEPARATELY AND USE THEM SEPARATELY.

R.O. Membrane Element Cleaning Instructions

Product Water Required, in Gallons for Cleaning of the R.O. Membrane Element:

Chemical	Rinse water required	Cleaning water required	Second Rinse water required	Final Rinse water required	Total water required
CC-1	5	5	5	5	20
CC-2	5	5	5	5	20
CC-3	5	5	5	5	20

1. Close the Cock Valve [2].
2. Replace the Pre-filtration Cartridge with a new SRC supplied Pre-filtration Element.
3. Configure the system for a Once Through Rinse.
4. Fill the 5-gallon container full with non-chlorinated product water. The bucket must contain enough product water to rinse the system until all of the feed water is displaced.
5. Open the Back Pressure Regulating Valve [17] fully open counterclockwise.
6. Operate the system by pressing the "Start" switch. The rinse water rinses the entire system and discharges out to waste.

7. Just prior to depleting the rinse water from the 5-gallon container, stop the system.
8. Fill the 5-gallon container with product water. NOTE: FOR OPTIMUM CLEANING RESULTS, USE WATER BETWEEN 90 F-110 F / 32 C –43 C. DO NOT EXCEED 120 F / 50 C.
9. Add 6 ounces (1/4 bottle) of either the SRC MCC-1, MCC-2, or MCC-3 Cleaning Chemical to the water in the plastic bucket. USE ONLY ONE CHEMICAL AT A TIME.
10. Mix and thoroughly dissolve the solution in the container.
11. The ratio for the Membrane Cleaning Chemical (MCC) is one bottle per 20 gallons of product water.
12. Configure the system for a Closed Loop Configuration.
13. Press the “Start” switch to begin circulating the Cleaning Chemical solution from the container through the system and back into the container. Do not pressurize the system; leave the Back Pressure Regulator Valve [17] fully open.
14. After approximately 60 minutes of circulation, stop the system (Press the stop button twice to abort the Fresh Water Flush Cycle). NOTE: If time permits, for best cleaning results, allow the cleaning solution to sit in the system for 4 to 6 hours and then reticulate the solution for an additional 20 minutes. This will allow the solution to soak, dislodge, and dissolve fouling.
15. Empty the 5-gallon container by reconfiguring the system for a Once Through Rinse.
16. Press the “Start” switch to discharge the solution out the Brine Discharge Thru Hull Fitting [18].
17. Just prior to depleting the Cleaning Chemical solution from the container, stop the system (Press the stop button twice to abort the Fresh Water Flush Cycle).
18. Fill the 5-gallon container full with non-chlorinated product water.
19. Again, configure the system for a Closed Loop Configuration.
20. Press the “Start” switch to circulate the water from the container through the system and back into the container. Continue rinsing for 20 minutes.
21. After 20 minutes, stop the system by pressing the “Stop” switch (Press the stop button twice to abort the Fresh Water Flush Cycle).
22. Empty the 5-gallon container by again reconnecting the Brine Discharge line to the normal position as described in Step 15.
23. Press the “Start” switch to discharge the rinse water out the Brine Discharge Thru Hull Fitting [18].
24. Just prior to depleting the rinse water from the 5-gallon container, stop the system (Press the stop button twice to abort the Fresh Water Flush Cycle).
25. Fill the 5-gallon container with non-chlorinated product water.
26. Start the system to begin final rinsing of the system and discharging out the Brine Discharge Thru Hull Fitting to waste.
27. Just prior to depleting the Final Rinse Water from the container, stop the system (Press the stop button twice to abort the Fresh Water Flush Cycle).
The system is now ready for additional cleaning, storage, or use.
28. If further membrane cleaning is necessary, repeat Steps 8 through 27 for each additional cleaning.
29. If cleaning is completed and the system is to be stored:
 - a) Press the “stop” switch once to place the Fresh Water Flush in the stand-by mode
 - b) Reconnect the system’s Suction and Discharge Lines to normal operating position.
 - c) Leave the Inlet Seacock Valve in the closed position.
30. If cleaning is complete and the system will be operated again within a short period of time:
 - a) Reconnect the system’s Suction and Discharge Lines to normal operating position.

Chapter 7

Troubleshooting

System Shuts Down During Operation

NUMBER ONE REPORTED PROBLEM IS "THE SYSTEM DOESN'T WORK"!

We can't help with this one unless you give us more information, or allow us to ask an unlimited number of questions.

NUMBER TWO REPORTED PROBLEM IS "System Shut Down By Itself" with "ERROR ID 2" or "ERROR ID 3" (High/Low Pressure Fault)

1. To clear the electronics Press Start/Stop Button
2. While observing Low and High Pressure Gauges Start System:
 - a. **ERROR ID 2:** If High Pressure Sensor increases beyond 950 PSI and System shuts down, then Press Start/Stop Button and check the Brine Discharge Section as well as the Product Line Section:
 - No kinks or blockages in the Brine Discharge Line
 - No kinks or blockages in the Product Water Line
 - b. **ERROR ID 3:** If Low Pressure sensor decreases to near or below 4 PSI, check the inlet line and associated components prior to the High Pressure Pump Inlet:
 - Cock Valve must be fully open
 - Check for air suction leaks at all components and fittings prior to the Feed Pump
 - Sea Strainer Mesh Screen clean manufacturing or installation debris and check for air suction leaks
 - Prefilter Element clean manufacturing or installation debris
 - Plankton Filter Element clean manufacturing or installation debris
 - No kinks or blockages in the inlet line and check for air suction leaks
 - Ensure that the Feed Pump is operational and delivering flow and pressure
 - Inlet Thru-Hull Fitting clean manufacturing or installation debris and check for air suction leaks
 - Caulking compound within the opening
 - Shipping cover or tape below the hull in the water
 - Casting slag on the "fingers" below the hull in the water or within the orifice
 - Plastic bag or other debris in the water below the hull in the water
3. Have patience with this one, and please read this carefully: Debris may plug up the Prefilter Element causing the system to shut down. After shut down, that same debris may settle off of the prefilter element and down into the prefilter housing bowl. Re-starting of the system may initially give normal readings. However, after a short period of time, the debris will stir up and once again clog the prefilter element causing the system to shut down due to low pressure.

Another cause may be a plastic bag or other debris attached to the thru-hull inlet fitting that finds its way over the thru-hull inlet then drops away when the system shuts down.

Still another cause may be an air suction leak at or prior to the Booster Pump (suction line at or prior to the Inlet of the Booster Pump). Within up to 10 minutes of operation, if the Low Pressure Gauge gradually decreases to near or below 6 PSI, check the inlet line and associated components prior to the High Pressure Pump Inlet:

- Sea Strainer Mesh Screen clean all debris and check for air suction leak

- Prefilter Elements replace
 - Plankton Filter Element clean debris from screen
 - Inlet Thru-Hull Fitting for debris, underneath the boat, and check for air suction leaks.
 - Cock Valve must be full open and check for air suction leaks
 - No kinks or blockages in the inlet line and check for air suction leaks from each fitting.
 - Ensure that the Booster Pump is operational and delivering flow and pressure
4. If system shuts down due to low or high pressure prematurely, then either the Low Pressure Switch or the High Pressure Switch may require adjustment or replacement. Refer to High and Low Pressure Switch Troubleshooting as well as High and Low Pressure Gauge Troubleshooting.

System Shuts Down By Itself

Voltage may have been interrupted causing the system to shut down. Check Voltage at the system inside the Control Panel. The system must receive adequate voltage at start up and during operation in order for it to operate normally.

- 12 VDC Systems shut down by design when the voltage falls below 11 VDC
- 24 VDC Systems shut down by design when the voltage falls below 22 VDC
- AC systems shut down by design when the voltage falls below 10% of the set voltage
- **ERROR ID 4** - DC systems shut down by design when the voltage falls below 10.5VDC

Check power cable wire size from the power source to the system to ensure that it is not undersized and causing voltage drop to the system. Check power cable wire connections from the power source to the system to ensure that they are tight.

System Shuts Down By Itself, and the system does not start when the start switch is pressed

Check power source circuit breaker.

- If the breaker has tripped and if this is a continual problem, check circuit breaker amperage rating to ensure that the proper circuit breaker has been installed.
- Occasionally a circuit breaker can be “weak” or defective causing premature trip.
- Have a qualified electrician check the circuit breaker with a full rated load to test its integrity.
- Check Power Wire Size to ensure that it is proper for the amperage rating of the system. Undersize wire will cause voltage drop and increased current.

System Shuts Down when the operating pressure is less than 950 PSI

1. Check the High Pressure Switch continuity. The High Pressure switch is “normally closed” and “opens” above 950 PSI.
 - Shut the system off, remove the leads from the High Pressure switch, and using an ohm meter ensure that the switch circuit is “closed”.
 - If the switch circuit is “open”, adjust the switch per instructions in the maintenance section of this manual.
2. Inspect the pressure gauge orifice inside the High Pressure Gauge port and dislodge debris within the orifice by cleaning or opening the hole with a small drill bit 1/32 nd inch / 1 mm diameter. Replace Gauge if necessary.

Pressure Readings, Pressure Gauges, and Pressure Switches Abnormalities

Low Pressure Gauge reading is below 6 PSI, but system remains operating

1. Inspect the pressure gauge orifice inside the Low Pressure Gauge port and dislodge debris within the orifice by cleaning or opening the hole with a small drill bit 1/32 nd inch / 1 mm diameter. Replace Gauge if necessary.
2. Check the Low Pressure Switch continuity. The low pressure switch is “normally open” and “closes” above 6 PSI.
 - Shut the system off, remove the leads from the low pressure switch, and using an ohm meter ensure that the switch circuit is “open”.
 - If the switch circuit is “closed”, adjust the switch per instructions in the maintenance section of this manual.

System remains in operation when the operating pressure is above 950 PSI.

High Pressure Switch has drifted from factory setting.

- Operate System and pressurize to 950 psi. Adjust High Pressure switch to “open” at 950 PSI.
- Replace switch if necessary.

Product Water Flow and Product Water Quality

The system is operating at 850 psi and is not producing specified product water flow

- **Feed Water salinity is greater than 35,000 PPM:** Higher salinity Feed Water Requires higher Pressure to make rated flow. Refer to Salinity Effects chart in this manual to identify expected pressure for Higher Salinity Feed Waters. Do not exceed 900 psi operating pressure.
- **System Feed Water temperature is lower than 77° Fahrenheit / 25° degrees Celsius:** Lower temperature feed water requires higher operating pressure to make rated flow. Refer to Temperature Effects chart in this manual to identify expected pressure for lower temperature Feed Waters. Do not exceed 900 psi operating pressure.
- **NEW System Initial Commissioning:** RO Membrane Element may have dried out between the time of installation and the time of commissioning. Contact the factory if this time period is uncertain. If this may be the situation, then operate system pressurized for 48 hours continuous to saturate and hydrate the R.O. Membrane Element. Only do this if it is known that the system was shipped months prior to installation and commissioning was performed months after installation, or if it is known that the R.O. Membrane Element has dried out.
- **RO Membrane Element has been in use for a period of time and is fouled from use:** If RO membrane element has been stored improperly without proper flushing and/or storage solution or if it has simply slowly degraded over time and use, then the Membrane may be fouled and cleaning may restore performance. If not, membrane should be replaced.
- **Membrane has chemical fouling:** If RO membrane element has been performing normally and the drop in production was sudden over one or two times of use it may be chemically fouled by petroleum or other pollutants.
- **Membrane has dried out:** If it is known that the R.O. Membrane Element has dried out operate system pressurized for 48 hours continuous to saturate and hydrate the R.O. Membrane Element.
- **R.O. Membrane Element has been exposed to temperatures in excess of 140 F / 60 C:** Replace R.O. Membrane Element.
- **There may be a restriction in the product water line:** Ensure that any valve in the product water line is fully open. Note: It is preferred and recommended that there are no valves in the Product Water Line. Ensure that any valve in the product water line is tight, a loose or easily turning valve handle will move and reposition itself due to the movement and pounding of the boat.

System produces more than rated product water flow when operating from full seawater salinity of 35,000 ppm or higher and the operating pressure is 400 PSI or lower and the Product Water Quality Lamp is illuminated “red”

1. A mechanical failure exists in the R.O. Membrane and/or High Pressure Vessel.
2. Cracked or broken RO Membrane Element product water tube which is caused by a blockage in the Product Water Line during operation
3. Cracked End Plug in the High Pressure Vessel allowing seawater to mix with Product Water which is caused by over tightening of tapered pipe fittings into the End Plug
4. Damaged or worn Product Water O-ring in the High Pressure Vessel End Plug
5. Lamination failure within the R.O. Membrane Element which is caused by a blockage in the Product Water Line and/or air entrapment in the High Pressure Vessel is normally associated with mounting the High Pressure Vessels vertically rather than horizontally.

ERROR ID 1: System produces expected rated product water flow with normal operating pressure after compensating for Feed Water Salinity and Temperature and the Product Water salinity is above 100ppm for more than 10 consecutive seconds

1. It is helpful to use a portable TDS meter to determine if the problem is with the R.O. Membrane Element or with the Salinity Probe and Electronic monitoring system.
2. Damaged or worn Product Water O-ring at one of the End Plugs within the High Pressure Vessel is allowing Feed Water to mix with Product Water. This would usually result in higher than normal Product Water Flow.

However, a small nick in the O-ring may allow enough Feed Water to mix with the Product Water to cause the condition without resulting in a noticeable increase in Product Water Flow.

3. Crack in one of the End Plugs within the High Pressure Vessel is allowing Feed Water to mix with Product Water. This would usually also result in higher than normal Product Water Flow. However, a small crack may allow enough Feed Water to mix with the Product Water to cause the condition without resulting in a noticeable increase in Product Water Flow.
4. R.O. Membrane Element is fouled due to normal use and requires cleaning.
5. Salinity Probe has debris on the probe causing the system to read poor water quality. Clean the Salinity Probe with a toothbrush.
6. Salinity Monitor out of calibration. Test the actual Salinity of the product water using a portable TDS meter. The system switches from potable water to un-potable water at 800 PPM TDS. If the salinity of the Product Water is less than 800 PPM TDS then calibrate the Salinity Monitor.

The Water Quality is less than 1000ppm, but the water has a definite salt taste.

1. Blockage or pressure in excess of 55 psi is present in the brine discharge line.
 - A blocked brine discharge line causes brine water to mix with product at the Diversion Valve. Flow through the flow meter will be normal because the flow meter is prior to the 3-way product water diversion valve.
 - Ensure that the brine discharge line is free from kinks and that any valves installed in the brine discharge line are fully open.
2. 3-way Product Water Diversion Valve requires mechanical adjustment or cleaning. Tube Connector fittings have been over tightened into the valve body causing the adjustment screws to move resulting in seawater bypass into the product water.
3. Salinity Probe has debris on the probe causing the system to read good water quality. Clean the Salinity Probe with a toothbrush.

Product Water is leaking from the Product Tubing when the Water Quality is less than 1000ppm.

Blockage or pressure in excess of 55 psi is present in the product outlet line from the system.

- Check all components and check for kinks or closed valves at and after the point of leakage.
- Charcoal Filter element is fouled, replace element
- pH Neutralizer element is fouled, replace element.
- 3-way Product Water Diversion Valve is blocked or inner ports are out of adjustment, adjust inner ports.

There is a Sulfurous odor (rotten eggs) in the product tank.

1. Dirty Pre-Filtration Element.
 - Dirty Pre-Filtration Elements allow biological matter to decay. When this biological matter decomposes, sulfur gas is released as a byproduct.
 - Check and replace as necessary Prefiltration and Post Filtration Elements.
2. Charcoal Filter Element requires replacement. Change the Charcoal Filter Element every 3 months.
3. Product Tank is dirty or has biological growth in it. Clean and Chlorinate product tank.

The UV sterilizer is flickering or does not light. (Ultra Violet light will damage skin and eyes. Do not look directly at the UV lamp)

1. UV lamp is weak due to length of time in use, in excess of 1,000 hours. Replace the UV lamp.
2. The UV ballast is very sensitive to voltage changes. Ensure that the voltage supplied to the UV sterilizer is within 11.5 VDC to 13 VDC.

3-way Product Water Diversion Valve Abnormalities

When the system is producing “unpotable” water and the Water Quality lamp is illuminated “red” the 3-way Product Water Diversion Valve coil will not receive voltage from the controller. This allows the 3-way Product Water Diversion Valve to divert the “unpotable” water to the Brine Discharge.

When the system is producing “potable” water and the Water Quality lamp is illuminated “green”, the 3-way Product Water Diversion Valve coil will receive 12 VDC from the controller. This allows the 3-way Product Water Diversion Valve to divert the “potable” water to the post filtration section and on to the boat’s potable water storage tank.

The Water Quality is less than 1000ppm, however, the Diversion Valve does not divert potable water to the post filtration section and on to the boat’s potable water storage tank.

The Diversion Valve is not energizing, and the valve’s coil is cool to the touch after several minutes of operation with the Water Quality is less than 1000ppm.

- The 3-way Product Water Diversion Valve may have a defective solenoid coil.
- There may be a loose wire connection at the Control Printed Circuit Board or the solenoid’s din connector.
- The Control Printed Circuit Board may not be delivering 12 VDC to the solenoid.

The 3-way Diversion Valve is receiving 12 VDC when the Water Quality less than 1000ppm safe water and the valve’s solenoid coil is not defective, the valve’s solenoid coil is warm or hot to the touch, however the Diversion Valve does not divert potable water to the post filtration section and on to the boat’s potable water storage tank.

The Diversion Valve internal ports may have been moved by over tightening of the black tube fittings causing blockage internally and require adjustment. Remove Diversion Valve from the system and adjust ports.

High Pressure Pump Abnormalities

High Pressure Pump flow is normal when the system operating pressure is below 100 PSI, but the flow drops or becomes erratic and pulsates as pressure is applied.

- Worn High Pressure Seals from normal use require replacement.
- Worn High Pressure Pump valves, valve seats, valve springs and/or valve seat "O" rings are broken or worn due to normal use and are allowing internal by-passing. Repair the pump with a Valve and Seal Kit.

Pump is noisier than usual and pulsations are observed in hoses and gauges.

- Worn or broken Valve, Valve Spring, or Valve Seat. Repair the pump with a Valve and Seal Kit.
- Pump is cavitating and not receiving sufficient feed water at its inlet due to blockage prior to the pump’s inlet port. Clear the blockage in the feed water line.

High Pressure Pump Leaks Oil

Determine source of leak and replace appropriate associated seal.

High Pressure Pump leaks water between manifold and Drive End.

- Worn Inlet Packings due to normal use
- Worn Inlet Packings due to operation under a vacuum condition
- Worn Inlet Packings because pump has been operated dry, without inlet feed water.
- Repair the pump with a Seal Kit.

If the High Pressure Pump electric motor fails to operate, follow these steps to isolate the problem.

1. Ensure that the system is receiving proper power from the power source.
2. Press “Start” switch to activate the motor. It will take approximately 10 seconds before the High Pressure Pump Motor starts. Do not press any other switch.
3. Measure the AC voltage between terminals 4 and 5 (AC Systems) or 3 and 4 (DC systems) on the main terminal strip.
4. If the voltage measured in the step 3 above matches the system voltage, then problems may be in the power cable attached to the motor or the motor internal wiring or windings.
5. If low or no voltage is present in step 3 above, then check for proper operation of the High Pressure Pump Contactor. To deactivate the contactor, press the “Stop” switch twice. To activate the contactor again, press the “Start” switch.
6. If the contactor is mechanically operating, but no voltage is present at the motor terminal (step 3 above), then the High Pressure Pump Motor contactor may be at fault.

7. If the contactor does not operate mechanically, then measure the DC voltage between A1 and A2 terminals on the High Pressure Pump Motor contactor coil. It should read 12V DC when activated.
8. If the contactor coil is receiving 12V DC but inoperative then the contactor's coil may be bad. Replace the contactor.
9. If 12V DC is not present when the High Pressure Pump is activated, trace the orange and orange/black wires to the main circuit board and measure the DC voltage at the terminals. It should read 12V when activated.

Booster Pump Abnormalities

If the Booster Pump electric motor fails to operate, follow these steps to isolate the problem.

1. Ensure that the system is receiving proper power from the power source.
2. Press "Booster Pump" switch to activate the motor. Do not press any other switch.
3. Measure the AC voltage between Terminals 1 and 2 on the main terminal strip in the controller.
4. If the voltage measured in the step 3 above matches the system voltage, then problems may be in the power cable attached to the motor or the motor internal wiring or windings.
5. If low or no voltage is present in step 3 above, then check for proper operation of the Booster Pump Contactor. To deactivate the contactor, press the "Stop" switch twice. To activate the contactor again, press the "Booster Pump" switch.
6. If the contactor is mechanically operating, but no voltage is present at the motor terminal (step 3 above), then the Booster Pump Motor contactor may be at fault.
7. If the contactor does not operate mechanically, then measure the DC voltage between A1 and A2 terminals on the Booster Pump Motor contactor coil. It should read 12V DC when activated.
8. If the contactor coil is receiving 12V DC but inoperative then the contactor's coil may be bad. Replace the contactor.
9. If 12V DC is not present when the Booster Pump is activated, trace the yellow and yellow/black wires to the Control Printed Circuit Board and measure the DC voltage at the terminals. It should read 12V when activated.

Electrical and Electronic Circuit Abnormalities

The Start Switch is pressed, but the system does not attempt to start.

1. System is in Fresh Water Flush Mode. Press Stop to exit Fresh Water Flush Mode. Press Start to operate the system.
2. The LCD on the Touch Pad is not illuminated
 - Reset the system circuit breaker.
 - There is no main Power to the system from the Power Source, investigate, and correct.
3. Blown Fuse in controller. Check and Replace fuse if blown.
4. Improper wiring. Ensure that system is wired correctly and that there are no loose wire connections.
5. Inadequate power source to the system
 - Ensure that the voltage does not drop below the industry standard of 10% of the full operating voltage set for the system. If the voltage drops below this standard during the system startup, the system will not start. High current is necessary to "excite" the electric motors. At the time of attempting to start the electric motors, they will consume high current. This may cause the voltage from the Power Source to drop dramatically for a fraction of a second which can be enough to cause the electronic circuit to shut off.
 - For D.C. systems it is instantaneous, and you will not hear or see this occur. D.C. systems ensure that the battery bank is fully charged and ensure that the wire size feeding the system is sufficient in diameter to carry the current without losing voltage. A.C. systems will usually result in the Generator loading down and the Generator R.P.M. slowing down.
 - Provide adequate power to the system.
6. Defective Start Switch on Touch Pad.
 - Test with Substitute Touch Pad.
 - Replace Touch Pad if one or more lamps or switches are found to be inoperable.

The Stop Switch is pressed, but the system does not stop.

1. Microprocessor has locked up. Turn main power off to the system at the power source circuit breaker for a minimum of 30 seconds to reset the microprocessor.
2. Defective Stop Switch on Touch Pad.
 - Test with Substitute Touch Pad.
 - Replace Touch Pad if one or more lamps or switches are found to be inoperable.
3. Water damage to printed circuit board.
 - Inspect Printed Circuit board for presence of water or corrosion from water.
 - If board had water spilled on it remove board from system, flush with distilled water, and thoroughly dry with hair dryer. Place board in low humidity area for minimum 24 hours. Shake the board to ensure that no water is left on the board. Reinstall and attempt to operate the system. If there is any sign of corrosion from water damage, replace it.

Fuse in the controller blows at startup.

1. Power source
 - There is either low voltage or high voltage into the system, below or above 10% of system set voltage.
 - Correct the improper power at the Power Source feeding the system.
2. Defective Component that relies on the fuse for power.
 - Check the 3-Way Diversion Valve, Printed Circuit board, Fresh Water Flush, UV Sterilizer (If installed), or the Touchpad.
 - Repair or replace Defective Component.

Product Water 3-way Diversion Valve does not switch to “safe water”, potable water.

1. First go to Section D. 3-WAY PRODUCT WATER DIVERSION VALVE ABNORMALITIES:
2. The Water Quality greater than 1000ppm the 3-way Product Water Diversion Valve is not energized, it is sending the Product Water to Brine Discharge over board. Using a hand held TDS Meter check the salinity of the Product Water. If the Salinity of the Product Water is greater than 800 PPM TDS then the Salinity controller is reading properly and diverting the “unpotable water” Product Water by not energizing the 3-way Diversion Valve. This is normal and the problem lies in the R.O. Membrane Element.
3. The Water Quality, however the 3-way Product Water Diversion Valve is not energized, it is sending the Product Water to Brine Discharge over board.

 **Danger:** ELECTRICAL SHOCK HAZARD. A Volt / Ohm Meter will be necessary. The following procedures expose the technician to High Voltage and electrical shock hazard. Only attempt this if you are a qualified electrician and only if surrounding conditions are safe.

With the system in operation and The Water Quality less than 1000ppm , remove the Controller Enclosure front panel to expose the inside of the controller box components.

With the system in operation and The Water Quality less than 1000ppm, measure the voltage at the terminals labeled 3-Way Product Water Diversion Valve. The voltage should be 12 VDC.

If no voltage is present replace the Control Printed Circuit Board.

Product Water salinity is confirmed (verified with a hand held TDS meter) to be less than 800 PPM TDS, however the Water Quality LED is illuminated RED “unpotable water”.

Salinity Control requires calibration.

Maintenance and Repair

Are you mechanically inclined? Troubleshooting and subsequent correction or repair will require understanding of:

- Electrical Circuits
- Electronic Circuits
- Electric Motors
- Hydraulic Systems
- Liquid Pressures and Flows
- Electro Mechanical Systems
- Mechanical knowledge and skills

Do not attempt troubleshooting and/or subsequent correction or repair if you are not familiar with or are not proficient in the above fields of expertise.

USE CAUTION WHEN TROUBLESHOOTING. DO NOT PERFORM MAINTENANCE UNLESS:

1. The system Feed Water Sea Cock Valve [2] is closed.
2. The system main electrical disconnect switch is switched "OFF", LOCKED, and TAGGED
3. The "EXPLODED PARTS VIEWS" of the this manual is available.

 **Caution:** ELECTRICAL SHOCK HAZARD. A Volt / Ohm Meter will be necessary. The following procedures expose the technician to High Voltage and electrical shock hazard. Only attempt this if you are a qualified electrician and only if surrounding conditions are safe.

Weekly Quick Check

The following steps ensure that potential problems are resolved preventing major repairs:

1. Inspect all fasteners for tightness including brackets, screws, nuts, and bolts. Pay special attention to the High Pressure Pump [11] and Electric Motor [10] since they are subject to increased vibration.
2. Ensure that Sea Strainer [3] and Plankton Filter [5], if either are installed, are clean and do not restrict flow.
3. Check the level of the High Pressure Pump [11] crankcase oil. The minimum oil level is the center of the sight glass, located at the side of the High Pressure Pump; the maximum oil level is at the top of the sight glass window. Use only SRC High Pressure Pump oil. **DO NOT USE MOTOR OR OTHER HYDRAULIC OIL.**
4. Clean any salt water or salt deposits from the system with a wet rag.
5. Check for fluid leaks; either oil from the High Pressure Pump or water from anywhere in the system.
6. Check all tubing and high-pressure hoses for wear and friction against abrasive surfaces. The hoses should not contact heated or abrasive surfaces.
7. Check Inlet Pressure to the High Pressure Pump. If pressure is below 10 psi after 5 minutes of operation, replace Pre-Filter element.

Operator Maintenance Intervals

The frequency of required maintenance is dependent on the regularity of usage, the condition of the intake water (the location of use), the length of time the system is exposed to water, the total running time and, in some cases, the manner in which the system is installed or operated. Because of these factors, it is virtually impossible to comprise an exact timetable for required maintenance. The following maintenance timetable is an estimate of the time intervals at which maintenance may be required on the various systems components. This is based upon factual data compiled from Sea Recovery installations around the world. However, this schedule must be adjusted to each individual system depending upon the variables listed.

COMPONENT	MAINTENANCE REQUIRED	TIME INTERVAL CONTINUOUS	TIME INTERVAL INTERMITTENT DUTY
Sea Strainer	Inspect and Clean	weekly	100 hours
	Screen and Housing		
Plankton Filter	Inspect and clean	weekly	100 hours
Pre-filter	Replace element	Low Pressure <6 psi	Low Pressure <6 psi
Flow Meter	Clean Inside of	As required when dirty	
	the clear tube		

COMPONENT	MAINTENANCE REQUIRED	TIME INTERVAL CONTINUOUS	TIME INTERVAL INTERMITTENT DUTY
High Pressure	Change oil	First 50 Hours New Pump Break In Period	
Pump		500 hours	Annually
	Replace Seal Kit	2000 hrs. / as required	2000 hrs.
	Replace Valve Kit	2000 hrs. / as required	2000 hrs.
R. O. Membrane	Clean Element	When production or salt rejection decreases by 10%	
Salinity Probe	Clean Probes	Annually	Annually
Charcoal Filter	Replace Element	3 months	3 months
U.V. Sterilizer	Replace lamp and clean quartz sleeve	2000 Hours	2000 Hours
Fresh Water Flush	Replace Element	3 months	3 months
Charcoal Briquette			

Other _____

Other _____

Other _____

Other _____

Other _____

Chapter 8

Electrical

Electrical Requirements and Information

Amperage Notes: The Electric Motors within the Aqua Mini 170 ,350, 550 & 750 systems start in series with time delay between each motor starting after the Touch Pad “Start” Switch is pressed. First, the Booster Pump starts, then the main High Pressure Pump Electric Motor starts. Alternatively, the Booster Pump may be started manually by pressing the “Booster Pump” Switch.

During start up, the current of the Booster Pump Electric Motor surges to “Locked Rotor” amperage for a fraction of a second after which the current drops to normal running load. Then the High Pressure Pump Electric Motor starts and surges to “locked Rotor” amperage for a fraction of a second after which the current drops to normal running load.

Therefore, the maximum surge current equals the Booster Pump Electric Motor normal running amperage plus the High Pressure Pump Electric Motor starting amperage. Normal operational amperage equals the normal operating amperage of the Booster Pump Electric Motor plus the normal operating amperage of the High Pressure Pump Electric Motor.

Power Source Requirements

Check line voltage and frequency to ensure that it agrees with system nameplate. Grounding and circuit protection should be done in accordance with National Electrical Code. See connection diagram on nameplate of motor or refer to the diagrams within this manual.

DC Systems

Voltage	HZ (AC)	Min. HZ	Max. HZ	Min. Voltage	Max. Voltage
12 VDC	N/A	N/A	N/A	11 VDC	15 VDC
24 VDC	N/A	N/A	N/A	22 VDC	30 VDC

AC Systems

120 VAC	60 HZ	58 Hz	62 Hz	108 VAC	132 VAC
230 VAC	60 HZ	58 Hz	62 Hz	207 VAC	253 VAC
100 VAC	50 HZ	48 Hz	52 Hz	90 VAC	110 VAC
220 VAC	50 HZ	48 Hz	52 Hz	198 VAC	242 VAC

Electrical Connections

 **Caution:** Always allow slack in electrical cables. Allow the cable to enter or leave from the strain relief in a straight manner for several inches to ensure proper connection, to relieve stress to the cable and fitting, and to allow ease of detachment and re-attachment for maintenance or replacement. If electrical cables are pulled tight causing them to bend at the strain relief, they will pull out of the strain relief causing a dangerous electrical shock condition, the wire may break, and the strain relief will lose its water-tight integrity.

1. Remove the front cover from the system controller to access the Main Terminal Strip and Printed Circuit Board.

REFER TO APPROPRIATE WIRING DIAGRAM ON THE FOLLOWING PAGES OF THIS SECTION.

2. Main Power: Insert main power cable through strain, see insert below. Connect main power cable leads to the system, see appropriate wiring diagram on following pages of this section.
3. Booster Pump: Insert Booster Pump power cable through strain relief, see insert below. Connect Booster Pump power cable leads to the system, see appropriate wiring diagram on following pages of this section.
4. Fresh Water Flush Solenoid Valve: Remove strain relief hold plug from the side of the control box, see insert below, and attach the Fresh Water Flush Solenoid Valve strain relief supplied with the Fresh Water Flush Accessory. Insert power cable through the strain relief. Connect Fresh Water Flush Solenoid Valve power cable leads to the system, see appropriate wiring diagram on following pages of this section.
5. U.V. Sterilizer: Remove strain relief hold plug from the side of the control box, see insert below, and attach the U.V. Sterilizer strain relief supplied with the U.V. Sterilizer Accessory. Insert power cable through strain relief. Connect U.V. Sterilizer power cable leads to the system, see appropriate wiring diagram on following pages of this section.
6. Remote Control: Remove strain relief hold plug from the side of the control box, see insert below, and attach the Remote Control strain relief supplied with the Remote Control Accessory. Insert power cable through strain. Connect Remote Control power cable leads to the system, see appropriate wiring diagram on following pages of this section.

Motor Rotation

Refer to Booster Pump and High Pressure Pump markings to determine proper rotation.

A.C. Systems: Refer to Booster Pump Electric Motor nameplate and High Pressure Pump Electric Motor nameplate for wiring connections and rotation notations.

DC Systems: The High Pressure Pump DC Electric Motor and Booster Pump DC Electric Motor rotation are polarity sensitive. If rotation is incorrect, check incoming polarity and individual motor wiring. Jog the motor by pressing the Start Switch and then quickly thereafter pressing the Stop switch.

Recommended Wire Sizes

 **Caution:** DO NOT USE ROMEX TYPE SOLID CORE WIRE. SOLID CORE WIRE CAN EASILY BREAK AND WILL NOT FIT OR SEAL INTO THE SUPPLIED STRAIN RELIEFS. USE ROUND JACKETED STRANDED WIRE PREFERABLY WITH AN OUTER JACKET DESIGNATION OF SJO OR SIMILAR COMPATIBLE WITH MARINE USE AND AN OILY ENVIRONMENT. FOR DC OPERATION FINE STRAND WIRE, SIMILAR TO BATTERY CABLE, IS PREFERRED FOR MINIMAL RESISTANCE AND MINIMAL VOLTAGE DROP.

Wire Size Cross Reference American Wire Gauge (AWG) vs. Metric Wire Sizes

AWG	Diameter Inch	Square Inch (In ²)	Diameter Millimeters	Square Millimeters (mm ²)
0000	0.4600	0.1661	11.6840	107.1649
000	0.4096	0.1317	10.4038	84.9683
00	0.3648	0.1045	9.2659	67.3980
0	0.3249	0.0829	8.2525	53.4609
1	0.2893	0.0657	7.3482	42.3871
2	0.2576	0.0521	6.5430	33.6069
3	0.2294	0.0413	5.8268	26.6516
4	0.2043	0.0328	5.1892	21.1385
6	0.1620	0.0206	4.1148	13.2913
8	0.1285	0.0130	3.2639	8.3626
10	0.1019	0.0082	2.5883	5.2588

AWG	Diameter Inch	Square Inch (In2)	Diameter Millimeters	Square Millimeters (mm2)
12	0.0808	0.0051	2.0523	3.3064
14	0.0641	0.0032	1.6281	2.0809
16	0.0508	0.0020	1.2903	1.3070
18	0.0403	0.0013	1.0236	0.8225
20	0.0320	0.0008	0.8128	0.5186
22	0.0254	0.0005	0.6452	0.3267

American Wire Gauge		Metric Wire Gauge	Metric Wire		
AWG	dia inch	sq. inch	dia mm	sq mm	Size mm
0000	0.4600	0.1661	11.6840	107.1649	100
000	0.4096	0.1317	10.4038	84.9683	85
00	0.3648	0.1045	9.2659	67.3980	65
0	0.3249	0.0829	8.2525	53.4609	50
1	0.2893	0.0657	7.3482	42.3871	40
2	0.2576	0.0521	6.5430	33.6069	32
3	0.2294	0.0413	5.8268	26.6516	32
4	0.2043	0.0328	5.1892	21.1385	19
6	0.1620	0.0206	4.1148	13.2913	13
8	0.1285	0.0130	3.2639	8.3626	8
10	0.1019	0.0082	2.5883	5.2588	5
12	0.0808	0.0051	2.0523	3.3064	3
14	0.0641	0.0032	1.6281	2.0809	2
16	0.0508	0.0020	1.2903	1.3070	1
18	0.0403	0.0013	1.0236	0.8225	0.8
20	0.0320	0.0008	0.8128	0.5186	0.5
22	0.0254	0.0005	0.6452	0.3267	0.35

Wiring Diagram Aqua Mini 24vdc

AQUA MINI 170 ELECTRICAL DIAGRAM 24 VDC Controller

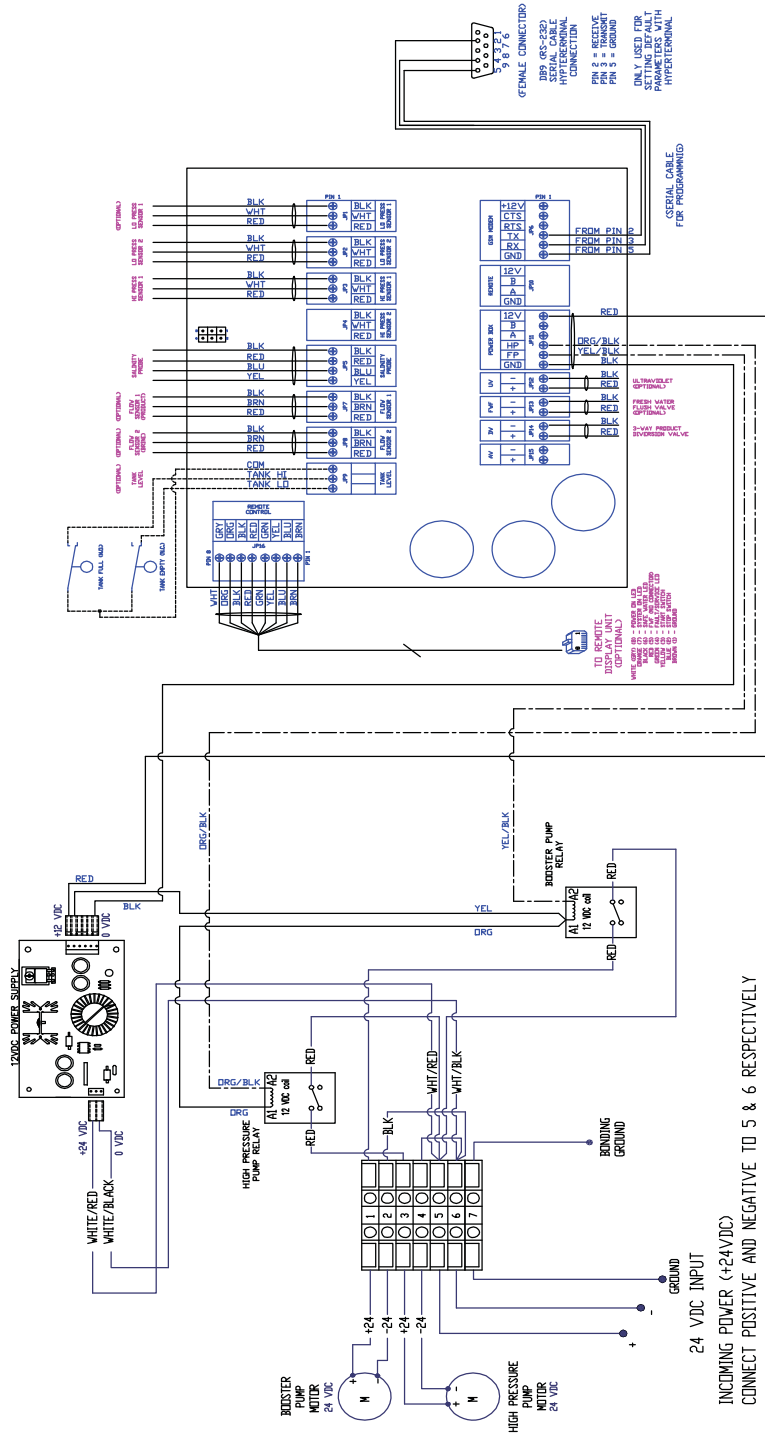

Chapter 9

Maintenance and Repair

Individual Component Maintenance and Repair

1. Inlet Thru Fitting [1]: Non Sea Recovery component. Keep the Inlet Thru Hull Fitting free and clear of debris and marine growth. If the Inlet Thru Hull Fitting is clogged, this results in a low feed pressure condition, which causes the system to shut off.
2. Cock Valve [2]: Non Sea Recovery component. The packings and connections of the Inlet Sea Cock Valve must be tight and must properly seal. Clean the valve cavity of debris or replace the seal and seat or the entire valve, as required. This section is under a vacuum condition while operating the system. Loose fittings or worn seal will allow air to enter the Sea Recovery system causing continual shut down due to subsequent low feed water pressure.
3. Sea Strainer [3]: Keep the mesh screen free and clear of debris. When the mesh screen is clogged, it results in a low-pressure condition causing system shut off. This section is under a vacuum condition while operating the system. If the Sea Strainer's bowl is loose or if the O-ring seal is worn or not properly seated, air will enter the system causing continual shut down due to subsequent low feed water pressure.

To clean the Sea Strainer:

- Remove the bowl by turning it counter-clockwise.
 - Remove the Mesh Screen from the bowl.
 - Remove the flat sealing gasket carefully from the bowl. The gaskets are fragile, so handle with care.
 - Wipe the sealing gasket with a damp cloth. Lubricate it sparingly with Parker "O" ring lubricant.
 - Place the seal back onto the bowl. Seat the mesh screen back into the bowl.
 - Screw the lid on clockwise. Hand-tighten only enough to seal water in and air out.
4. Booster Pump[4]:

Aqua Mini 170 Booster Pump with Electric Motor: This booster pump is not economically repairable. Replace the pump if it fails to deliver the proper flow or pressure to the system. Do not replace this pump with an intermittent duty pump found in marine stores. Use of a different pump may cause motor over heating, damage to the Control Box components, insufficient feed water pressure, or continual shut down of the Aqua Mini 170. The SRC Aqua Mini 170 Booster Pump is specifically manufactured for Sea Recovery for use as a continuous duty Feed Water Booster Pump for the Aqua Mini 170 and available only through an authorized Sea Recovery Service Dealer or directly through Sea Recovery.

UV Light Maintenance

Follow the preventative maintenance procedures to maximize the efficiency, reliable, and longevity of the UV unit. Refer to for recommended maintenance schedule.

 **Danger:** The most important consideration is operator safety. The following directly relates to operator safety. All personnel must review and comply with the following.

 **Caution:** Operators must observe Safety Requirements at all times

Safety Requirements

The following safety requirements are mandatory. Failure to comply can cause injuries and/or damages to the UV unit.

1. Never look directly at the blue ultraviolet lamp when it's "ON". Never operate the ultraviolet lamp outside the stainless steel cabinet. UV light exposure can severely burn and damage eyes and skin.
2. Properly ground the UV unit. Failure to properly ground the UN unit can cause severe electrical shock hazard.
3. Provide watertight piping and compression nut seals. Failure to provide watertight seals can cause damage to electrical components or cause electrical shock hazard.
4. Disconnect power before servicing the UV unit. The UV lamp and electrical components operate with high voltage electrical power. Do not attempt to service the UV unit without first disconnecting the power source. Shut off the source of power at the main panel breaker and use appropriate tag-out or lock-out procedures to prevent accidental power-up.
5. Only qualified service personnel should perform services to the UV unit.
6. Remove pressure before servicing the UV unit.
7. Never operate the UV unit for more than 30 minutes without water flow. Elevated water temperature can damage the UV unit.
8. Do not exceed 3 "Start/Stop" cycles per 24-hour period. Exceeding 3 cycles will subjected the lamp filament to excessive thermal stress leading to premature failure of the UV lamp.

Unit Maintenance

The exterior surfaces of the UV unit should be kept clean and dry. In most cases it may be necessary to clean the exterior of the unit once a month. Use soft cloth and soapy water, or any commercial stainless steel cleaner.

Interior of the ballast box should be inspected for debris. Any debris should be removed using vacuum.

Quartz Sleeve

Debris and other matter in the water will settle onto the quartz sleeve and eventually block the ultraviolet rays from penetrating into the water. It is necessary to determine a cleaning schedule for the quartz sleeve. The frequency will depend on the specific type of water being processed and the duty cycle of the unit.

Inspect the quartz sleeve 30 days after initial installation to assess the amount of contamination collected over the 30-day period. Use the finding to determine a reasonable schedule and frequency for periodic cleaning.

Clean-In-Place (CIP) cleaning is sometimes effective in removing debris from the quartz sleeve. Conduct a CIP cleaning test to determine its effectiveness. If CIP cleaning is not effective, then a manual cleaning or replacement is required.

When the quartz sleeve is due for cleaning, use the following procedures.

1. Turn off the water source to the UV unit.
2. Disconnect the power source to the UV unit.
3. Drain the UV treatment chamber.
4. Remove the ballast box cover.



5. Remove rubber boot and carefully pull out the UV lamp through the compression nut pass-thru.

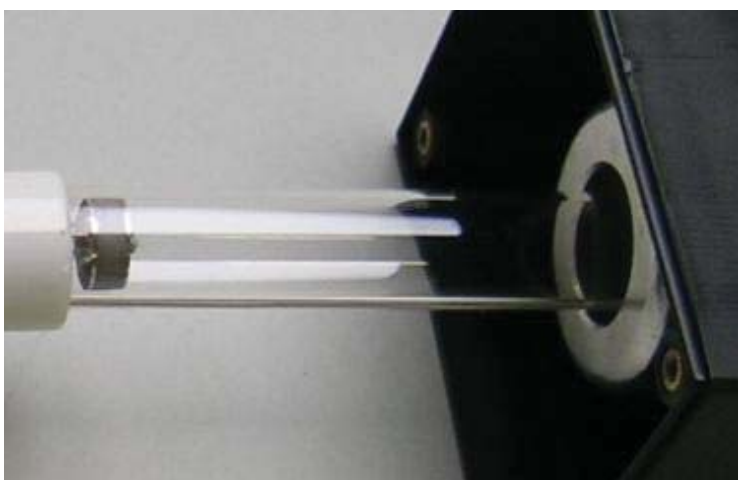

6. Use a channel lock to remove the compression nuts.
7. Remove the Quartz Sleeve carefully.



8. Wash the Quartz Sleeve with mild soapy water and rinse in clean hot water.
If dirt remains after rinsing, the quartz sleeve should be replaced. Contact your local CSR to order a replacement.

-
- ✔ **Note:** Failure to perform quartz sleeve maintenance may reduce the efficiency of the UV light to adequately treat water in the treatment chamber.

Checking for Leaks

Visually inspect the UV unit exterior for signs of leakage. The cause of any leakage must be located and repaired.

If a leakage is detected, perform the following.

1. Shut off all electrical power. Shut off the source of power at the main panel breaker and use appropriate tag-out procedures to prevent accidental power-up.
2. Depressurize the UV unit.
3. Remove ballast box cover and remove the rubber boot.
4. Locate which end of the quartz sleeve is leaking.



Repairing Leaks

If both ends of the quartz sleeve are leaking, perform the following on both ends.

1. Use a channel lock to loosen and remove the compression nut.
2. Remove the quartz sleeve O-ring without pulling the quartz sleeve out.

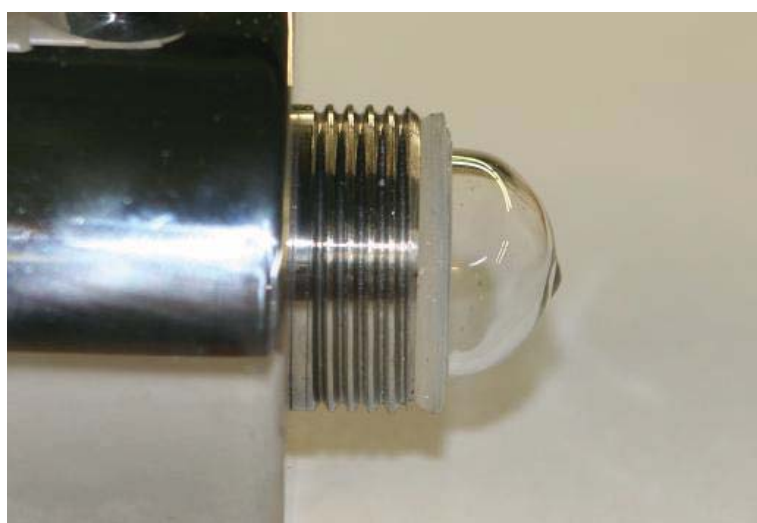
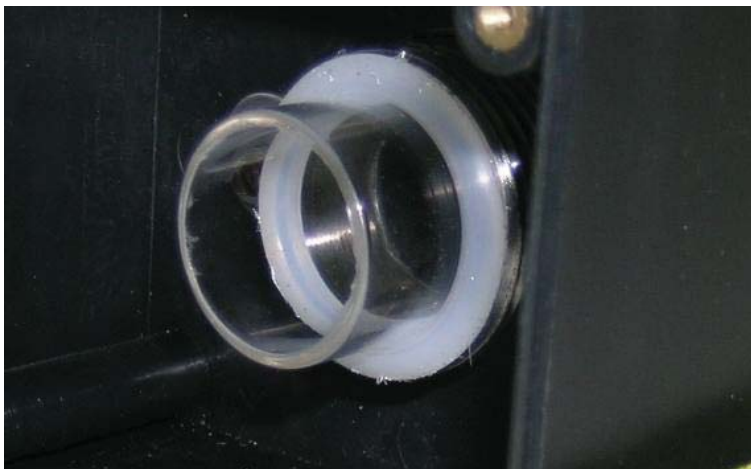

3. Lubricate the quartz sleeve tip with clean water and place new O-ring. Ensure the O-ring has all-round contact with the cylinder pass-thru.
4. Replace and tighten the compression nut.
5. Refill the treatment chamber and verify a leak-free condition.

Measuring Performance

Every UV unit must be tested periodically to verify its efficiency. Regardless of the intended application or any optional equipment provided with the UV unit, the most accurate procedure is the Post-UV Analysis. The Post-UV Test must be performed in accordance with standard testing methods.

Verifying Lamp Operation

The UV lamp is "ON" when the blue light is emitting thru the viewport.

Obtaining Water Samples

Vast majority of unsatisfactory Post-UV Test results are directly related to the improper sample-taking techniques. Although several commercial sample collection apparatuses are available, the proper manufacturer's sample procedures must be followed.

 **Note:** Sea Recovery recommends a valve with a discharge orifice not to exceed 3/8" (6mm).

Sampling Procedure

Use sterile sample bottles obtained from reliable laboratory that has been autoclaved and kept in plastic bag for this procedure.

1. Use temporary tube to direct water from UV unit to container or drainage.
2. Pressurize the UV unit and flush unit with sample valve fully opened for 3.5 minutes. After flushing for 3.5 minutes, reduce valve opening to 50% and flush for 3 minutes.
3. Open the sample bottle and keep the inside of the cap facing down.
4. Fill the sample bottle and avoid breathing directly into the bottle or touching the inside of the bottle, cap, or neck.
5. Immediately cover and secure the cap after filling the sample bottle.
6. Label the sample bottle and place in a clean plastic bag.
7. Take sample bottle to the laboratory for plating as soon as possible.



Note: Sample processing must begin within 3 hours after sample collection and must comply with accepted standard methods.

Periodic Maintenance Table

The table below represents the recommended Periodic Maintenance (PM) for the SP Series UV Unit.

Table 11: Periodic Maintenance Table

Description	Init.	Daily	Mn	Ann.	Other
Quartz Sleeve Cleaning	x				
Quartz Sleeve Replacement*	x				
Operating Condition	x				
Unit Cleaning	x		x		
Leak Inspection	x	x	x		
UV Lamp Inspection	x	x	x		
UV Lamp Replacement-SP-1				x	4,400 hrs
UV Lamp Replacement-SP-2				x	8,000 hrs

* Quartz Sleeve replacement will occur more frequently for systems operating with continuous high flow rate or low water quality water, and less frequently for systems operating with low flow rate or high water quality.

Quartz Sleeve Cleaning

1. Remove the four screws on the ballast box and remove lid.
2. Remove the rubber boot and carefully pull lamp out of the quartz sleeve.
3. Unscrew and remove the two compression nuts (ballst box and view port).
4. Remove the O-ring on the view port side only.
5. With care pull the quartz sleeve out from the ballast box side.
6. Clean the quartz tube with water and a bottlebrush without moving the O-ring . Dry with a soft cloth. Handle the quartz sleeve carefully.

Quartz Sleeve Reassembly

1. Replace old O-rings with new O-rings.
2. Insert the quartz sleeve (close-end first) through the ballast box passthru until O-ring contact passthru. Screw on the ballast box compression nut. Insert view port O-ring and screw on view port compression nut..

3. Attach a new U.V. Lamp into the plug.
4. Slide the lamp into the Quartz Sleeve and install rubber boot over the compression nut.
5. Replace the three 1/4-20 cap head screws.

Ultraviolet Sterilizer [23]

The UV Sterilizer lamp emits a low frequency form of light. This light degrades and loses intensity and ability to sterilize biological matter over approximately 4,000 hours of use. Therefore, the lamp may remain lit, but requires replacement every 4000-8000 hrs.

 **Caution:** Make sure that system power is turned off before beginning sterilizer maintenance. Ultra Violet light is harmful to eyes and skin.

Lamp Replacement:

1. Remove the four screws on the ballast box and remove lid.
2. Remove the rubber boot and carefully pull lamp out of the quartz sleeve.
3. Replace the lamp. During lamp replacement clean the quartz sleeve as well. The quartz sleeve should be crystal clear and if it has discolored, it must be cleaned or replaced.

Charcoal Filter [22]

A sulfurous (rotten eggs) odor from the product water requires the replacement of the Charcoal Element. Otherwise, the Charcoal Element should be replaced every 3 to 4 months. It is not cleanable.

To replace the Charcoal Filter Element:

1. Unscrew the bowl counter clockwise.
2. Remove the Charcoal Filter Element from the bowl.
3. Remove the O-Ring from the top of the bowl and take care to not damage it.
4. Replace the Charcoal Filter Element with a new Sea Recovery element.
5. Wipe the O-Ring with a damp cloth.
6. Lubricate the O-Ring lightly using a sparingly amount of O-Ring lubricant.
7. Place the O-Ring back onto the bowl.
8. Insert the new, Sea Recovery Charcoal Filter Element into the bowl.
9. Screw the bowl on clockwise.
10. Hand snug to seal the O-Ring, do not use a wrench or other tool to tighten, do not over tighten. Over tightening may damage the threads in the bowl or housing and over tightening will cause removal to be difficult.

The 3-way Product Water Diversion Solenoid Valve [21]

Over tightening of the tube fittings into the valve's body can cause the Diversion Valve internal ports to move out of proper position resulting in internal blockage or bypassing.

1. Remove Diversion Valve from the system and adjust ports.
2. Position the manual over ride button OUTWARD to normal position by first pushing the button inward and rotating it counter clockwise allowing it to spring outward away from the coil body.
3. With your mouth, blow into port "P", air should expel from port "B" which is the "normally open" or "bad water" port.
4. If it is extremely difficult to expel air from port "B" or if no air expels from port "B", then port "B" requires adjustment.
5. Again blow into port "P" while plugging port "B" with a finger tip. No air should expel from port "A".
6. If air expels from port "A", then port "A" requires adjustment.
7. Position the manual over ride button INWARD to manual over ride position by pushing the button inward and rotating it clockwise allowing it to lock inward close to the coil body.

8. With your mouth, blow into port “P”, air should expel from port “A” which is the “normally closed” or “good water” port.
9. If it is extremely difficult to expel air from port “A” or if no air expels from port “A”, then port “A” requires adjustment.
10. Again blow into port “P” while plugging port “A” with a fingertip. No air should expel from port “B”.
11. If air expels from port “B”, then port “B” requires adjustment.

Solenoid Valve Coil Check

The 3-way Product Diversion Valve Solenoid operates from 12 VDC. To check the condition of the Diversion Valve solenoid coil:

- a) While System is operating and while the Water Quality less than 1000ppm, remove the din connector from the valve’s coil. Using a voltmeter set to DC, check the voltage at the din connector terminals.
- b) If 12 VDC is present at the din connector terminals then the control circuit is operating normally, but the 3-way Diversion Valve Coil may be defective. Check the solenoid coil continuity.
- c) Using an Ohm meter measure the continuity of the solenoid coil as shown below.

Measure the DC resistance between pins 1 & 2. Proper resistance reading is approx. 12 to 15 W .

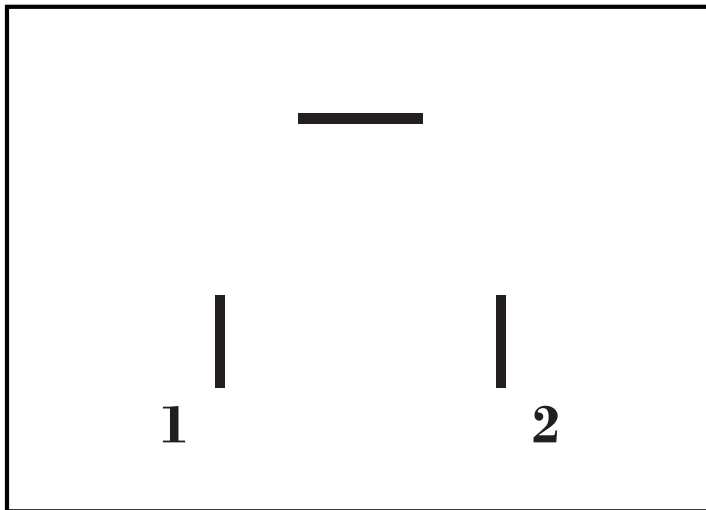

- d) If an open circuit exists, or if the resistance is much greater than or less than 12 to 15 , then replace the solenoid coil or the entire valve.
- e) If 12 VDC is not present at the din connector terminals, then the cable connections may be loose, the cable may be broken, or the control circuit may be defective. Check these components.
- f) Check for 12 VDC at the connection points of the Diversion Valve Solenoid Coil on the Control Printed Circuit Board terminals.
- g) If 12 VDC is present while system is operating and the Water Quality less than 1000ppm, then the Diversion Valve cable is loose at one of the connections or the cable is defective.
- h) If there is no voltage present while system is operating and while the “safe water” lamp on the Touch Pad is illuminated green, then troubleshoot the Control Printed Circuit Board.

Flow Meter [20]

Since the flow meter body is clear, light penetrates it and supports biological growth. To clean the flow meter body, remove the top access fitting, the guide rod, float and O-Ring bumpers, and tube stops. Clean the interior of the tube using a bottlebrush, soft rag, cotton swab or other soft item. Reassemble the unit.

High Pressure Pump Electric Motor

Troubleshoot electric motor failure to ensure that any abnormality from the power, wiring, wiring connections, contactor, or control circuit are not at fault or at cause. If the electric motor has failed, it will require replacement. Depending upon failure, replacement may be more cost effective than repair. If failure of the motor is due to external source, not the motor itself, then correct the cause or else the replacement or repaired motor will fail again.

Failures of the electric motor may be:

- Bearing failure. Bearings are field replaceable.
- Winding failure. Generally caused by low or high power, below or above the specified voltage requirements of the system, and feeding the motor. This is Not economically repairable.
- Internal centrifugal switch. Generally mechanical failure of the switch. Field replaceable.
- Capacitor failure. Generally caused by low power feeding the motor. Also caused by rapidly repeating starting and stopping of the motor. Field replaceable.

Back Pressure Regulator [17]

If the Back Pressure Regulator valve leaks from the valve stem, lightly tighten the packing gland nut located below the valve stem. Should adjustment fail to stop the leak, replace the stem and internal packing or replace the entire valve.

High Pressure Gauge [15]

If the pressure gauge fails to register, the orifice may be corroded with debris. Use a thin wire or small diameter (1/64th" / 0.4 mm) drill bit to dislodge any debris trapped within the pressure port orifice. If clearing the orifice does not bring the gauge to normal operation, then replace the gauge.

High Pressure Pump [11]

Failure Signs and possible causes (troubleshooting):

1. Abnormally High Pulsations at the High Pressure Gauge are caused by
 - Worn or broken Valve
 - Worn or broken Valve Spring
 - Worn or broken Valve Seat
 - Debris in Valve Chamber
2. Water Leak between the High Pressure Pump Manifold and Rear Section caused by.
 - Worn Low Pressure Seals
 - Low Pressure Seals damaged due to running dry.
3. Flow drops dramatically when attempting to pressurize and/or unable to build pressure. This is caused by:
 - Worn High Pressure Seals
 - High Pressure Seals damaged due to running dry
 - Broken Valve
 - Broken Valve Spring
 - Debris in Valve Chamber

High Pressure Pump Servicing

Disassembly of the Discharge Valve Assemblies

Tools required: 3/8" Drive Ratchet; 6 mm Hex Socket; O-Ring Pick; Two slotted screwdrivers, Torque Wrench; Needle Nose Pliers.

Only one valve kit is required to repair all of the valves in one pump. The Valve Kit includes new valve O-Rings, valve seats, valves, and springs.

1. Disconnect all plumbing.
2. Remove the six socket head screws from the manifold. Remove the outer screws first, then the inner screw.
3. Using a soft mallet, tap the back side of the Discharge Manifold from alternate sides to maintain alignment and avoid damage to the plungers
4. Grasp the Discharge Manifold from the underside and gradually lift manifold while you pull away from the Crankcase.
5. The Adapter/Spacers may stay with either the Discharge or Inlet Manifold. By inserting two opposing screwdrivers between Spacer and manifold, you can easily remove them from the Discharge Manifold. If they stay in the Inlet Manifold, gently work them up and down as you pull away from the Inlet Manifold.
6. The Valve Assemblies are in the Discharge Manifold ports and will fall out when manifold is turned over.

Disassembly of the Seal Assembly

Tools Required: 3/8" Drive Ratchet; 6mm Hex Socket; Packing Extractor; and Colette.

1. Remove the Inlet Valve Assembly from the exposed plunger rod ends, including Cotter pin, Nut, Washer, Spring, Spacer and Inlet Valve.
2. Grasp the Inlet Manifold from the front and underside and pull to remove from Plunger Rods.
3. Carefully examine backside of Low Pressure Seal before removing from manifold as it will be damaged during removal. If worn, insert screwdriver into I.D. of seal and pry out. Exercise caution to avoid damage to the Inlet Manifold.
4. Press ceramic Plunger with thumb or soft tool from backside of Inlet Manifold. (The High Pressure Seal may stay with the plungers or remain in the Inlet Manifold. If on the plungers, slide off by hand. If in the manifold, use reverse pliers to remove.)
5. Remove Seal Retainers from Crankcase by grasping tab with pliers and pulling out.
6. Examine Crankcase Oil Seal to determine if Crankcase servicing is needed.
7. Examine Ceramic Plunger, Low Pressure Seals, V-Packings for scoring, cracks, and wear and replace if needed.

Reassembly of Seal Assembly

1. Examine Seal Retainers and replace if worn or damaged. Install on Plunger Rod and press into Crankcase with tab out.
2. Place Inlet Manifold on work surface with Crankcase Side up.
3. Lubricate new Low Pressure Seals and press into position with garter spring down. Be certain the seal is seated squarely on the shoulder on the inlet manifold chamber.
4. Place the inlet Manifold on work surface with Crankcase side down (Larger ID ports up).
5. Carefully examine the Plungers for scoring or cracks and replace if worn.
6. Lubricate Ceramic Plungers and new High Pressure Seals. Press the plunger into the seal and position seal in middle of plunger. NOTE: Place the deeper recessed end of the plunger into the seal from the metal backside.
7. Insert the Plungers into the manifold ports. Press into position using the larger I.D. end of Discharge Valve Spacer. Examine the O-Ring and Back-up-ring under the Sleeve for cuts or wear and replace. Examine the Barrier Slinger for wear and replace as needed. Install the Barrier Slinger with the concave side facing away from the Crankcase. Lubricate the Plunger Rod O-Ring to avoid cutting during installation. Install the Back-up-ring first then the O-Ring into the groove on the Plunger Rod. Install the Sleeve with the tapered end facing out. Gently press towards the Plunger Rod shoulder until flush with the Barrier Slinger.
8. Carefully install Inlet Manifold over Plunger Rod ends and slowly press into Crankcase.
9. Examine Inlet Valve and replace if worn. Inlet valves cannot be reversed if worn. The SS Inlet Valves may be lapped if not badly worn. Install the SS Inlet Valves with square edges towards the plungers (round edges towards the discharge). Install the Nylon Inlet Valve with ridged side towards the discharge.
10. Examine Spacers for wear and replace as needed. Install Spacer on each Plunger Rod with smaller O.D. towards inlet valve.
11. Examine Springs for damage or fatigue and replace as needed. Place on Plunger Rods.
12. Install Washers next with concave side towards Inlet Manifold.
13. Install Nuts and torque to 55 in. lbs. / 4 ft. lbs. / 4 Nm.

14. Always install new Cotter pins and turn ends to secure in position.

Reassembly of the Discharge Valve Assembly

1. Examine Adapter Spacer O-Rings and replace if worn. Lubricate and install O-Rings and Back-up-Rings on both front and rear of the Adapter Spacer.
2. Examine the Valve Retainers for scale build up or war and install into each Discharge Manifold port with tab down into the manifold chamber.
3. Replace worn or damaged springs and place into Retainers.
4. Examine Valve and Seats for pitting, grooves, or wear and replace as needed.
5. Place Valves over springs with concave side down.
6. Place Valve Seats on Valves with concave side down.
7. Lubricate O.D. of Adapter/Spacer and insert smaller I.D. into Discharge Manifold ports. Snap into position. Exercise caution not to cut or pinch O-Rings.
8. Carefully guide Discharge Manifold with Spacers over Plunger Rod ends and press into Inlet Manifold.
9. Replace Socket Head Screws and torque to 115 in. lbs. / 9.4 ft. lbs. / 13 Nm
10. If oil was not changed, be sure oil it is at the proper level on the sight gauge.
11. Torque sequence for tightening the manifold:

3	1	5
X	X	X
X	X	X
6	2	4

Reverse Osmosis Membrane Element Replacement



Note:

- The Aqua Mini Membrane Element is accessible with the Vessel still attached to the frame.
- Replace all Brine and Product Water O-Rings attached to the End Plugs within the High Pressure Vessel Assembly each time the Reverse Osmosis Membrane Element is removed or replaced. Ensure these O-Rings are on hand prior to repair.
- Membranes are only installed and removed from the INLET end of the High Pressure Vessel.

Tools Required:

5/16" Allen wrench

regular pliers

Needle-Nose Pliers

1. Disconnect the High Pressure Hose from each end of the High Pressure Vessel Assembly.
2. Using a 5/16" Allen wrench remove the 3 each Socket Head Cap Screws from the three-piece Segment Rings located at each end of the Pressure Vessel.
3. Push inward on the End Plug and Remove the three-piece segment ring from one end, repeat for the other end.
4. Remove the Port Retainer from each end.
5. Remove the from each end.
6. Remove the product water tube from the respective end.
7. Insert all three of the Socket Head Cap Screws back into the End Plug. These screws are used as a grip to remove the End Plug.
8. Grasp one or more of the Socket Head Cap Screws with a pair of pliers and pull slowly outward to remove the End Plug. There is some resistance due to the two Brine O-Rings exerting friction against the Vessel wall. With the End Plug removed from the High Pressure Vessel, the Reverse Osmosis Membrane Element is visible.

9. Remove and discard the brine O-rings from each of the End Plugs.
10. Remove and discard the Product Water O-rings from each of the End Plugs.
11. Clean the end plugs with a cloth and inspect each for any sign of wear, cracks, or damage.
12. Sparingly, lightly, lubricate:
 - 4 (four) NEW Brine O-Rings and 4 (four) new Product Water O-Rings for the Aqua Mini 170 or
 - 4 (four) NEW Brine O-Rings and 2 (two) new Product Water O-Rings for the Aqua Mini 350
13. Place the NEW Product Water O-Rings into the product port inner O-Ring groove in each of the End Plugs.
14. Place the NEW Brine O-Rings onto the outer Brine O-Ring grooves of each of the End Plugs.

⊘ Caution: At each end of the Reverse Osmosis Membrane Element is a Product Water Tube approximately ½" diameter by 1" long. The outside diameter surface of this product water tube is a sealing surface, which isolates the Product Water from the Feed Water. The surface of the Product Water Tube must be scratch free. Never use pliers or other grabbing tools on the Product Water Tube. Do not drop the R.O. Membrane onto a hard surface as the Product Water Tube may be damaged.

15. With your fingers grasp the Product Water Tube attached to the R.O. Membrane Element from the INLET end of the Pressure Vessel and pull outward. If resistance is met then cup the INLET end of the High Pressure Vessel with one hand and shake downward to dislodge the R.O. Membrane Element.
16. Run a rag through the High Pressure Vessel to remove any biological film or debris from the High Pressure Vessel.

A new Sea Recovery R.O. Membrane Element comes complete with a "U" cup Brine Seal at one end of the Element. This Brine Seal must be positioned at the INLET end of the Pressure Vessel.

INLET End	OUTLET End
Feed Water Entry End	Brine Discharge End
R.O. Membrane Element Brine Seal End	no brine seal on this end

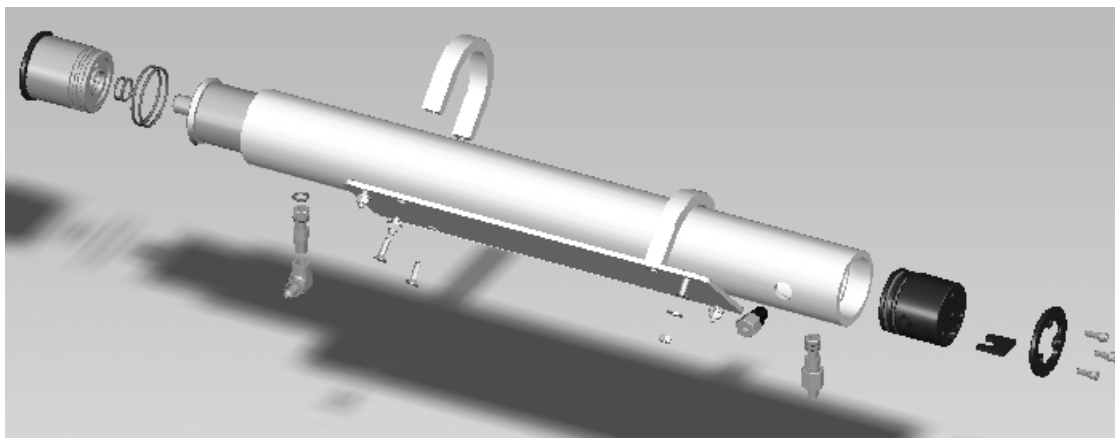

Install a new R.O. Membrane Element with attached "U" cup Brine Seal into the Pressure Vessel. Place the end of the R.O. Membrane Element that DOES NOT have the Brine Seal attached into the INLET end of the Pressure Vessel and slide it into the Pressure Vessel. (Insert the down stream end [end without a brine seal] of the Reverse Osmosis Membrane Element into the upstream inlet end of the High Pressure Vessel.)

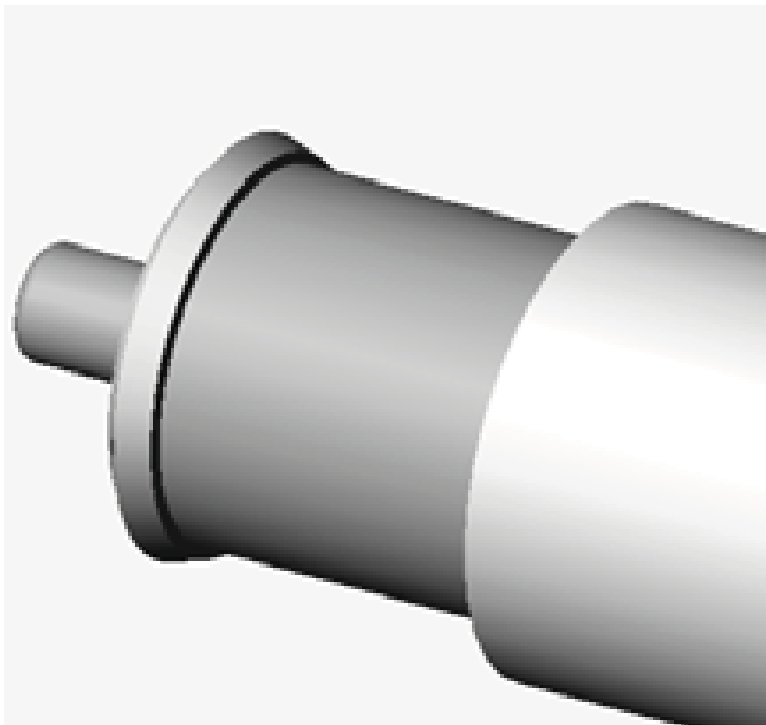

Figure 1: Inlet end of Pressure Vessel Brine Seal End of R.O. Membrane Element

17. Slide the Membrane Element into the High Pressure Vessel, past the brine seal, until the Membrane Element product water tube is 4 inches past the end lip of the High Pressure Vessel.
18. Insert the End Plug with new attached O-Rings into the High Pressure Vessel while aligning the High Pressure Port and Product Water Port to the respective holes in the High Pressure Vessel. Continue pushing inward on the End Plug until its exposed end travels just past the Segment Ring Groove in the Pressure Vessel. Ensure that the Ports of the End Plug are aligned with the Port Holes of the High Pressure Vessel.
19. Insert the High Pressure Port Fitting with attached O-Rings into the High Pressure Port.
20. Replace the Port Retainer.
21. Insert the three-piece Segment Ring Set into the Segment Ring Groove of the High Pressure Vessel. Align the Segment Ring Set with the tapped holes in the End Plug for insertion of the three Socket Head Cap Screws. Attach the three Socket Head Cap Screws and tighten.
22. Connect the High Pressure Hoses to the respective fitting on the Pressure Vessel.

Plankton Filter [5]

Element Cleaning: Identical procedure for Pre-filter and Charcoal Elements

1. Unscrew the bowl counter clockwise.
2. Remove the Plankton Filter Element from the bowl.
3. Remove the O-Ring from the top of the bowl. The O-Ring is fragile, so handle it with care.
4. Clean the mesh screen filter element with a bristle brush and water spray.
5. Wipe the O-Ring with a damp cloth.
6. Lubricate the O-Ring lightly using a sparingly amount of O-Ring lubricant.
7. Place the O-Ring back onto the bowl.
8. Insert the cleaned or a new plankton filter element into the bowl.
9. Screw the bowl on clockwise.
10. Hand snug to seal the O-Ring; do not use a wrench or other tool to tighten; do not over tighten. Over tightening may damage the threads in the bowl or housing and will cause removal to be difficult.

Pre-filter [6] Element Replacement

The Prefilter Pleated Cartridge Element may be cleaned with water spray once or twice. After cleaning the expected life will be reduced in half. Attempts to clean the element more than twice will result in a very short life and will damage the element rendering it useless. Change the element after the first or second cleaning. Clean or replace the element when plugged to the extent that the Low Pressure Gauge at the control panel reads 10 to 6 psi. At slightly below 6 PSI, the Low Pressure Switch shuts the system off.

 **Caution:** Do not use third party prefilter elements; use only Sea Recovery Prefilter Elements. Third party prefilter elements on the market do not properly fit, the seams fall apart, they will allow by-pass, and will allow the R.O. Membrane Element to foul prematurely. Use of third party prefilter elements will void any and all Sea Recovery warranty to the High Pressure Pump and the R.O. Membrane Element.

 **Important:** Do not use “string wound” or “fiber” prefilter elements. These types of elements are designed for the Photographic Film Developing industry. When used in sea water, they will plug up rapidly in 1/10th or less the time causing frequent shut down of the system and very frequent changing which will also lead to very high cost of maintenance. Use of String Wound or Fiber type elements will only lead to user frustration and very high maintenance costs. Use of third party prefilter elements will void any and all Sea Recovery warranty to the High Pressure Pump and the R.O. Membrane Element.

To clean or replace the Prefilter Element:

1. Unscrew the bowl counter clockwise.
2. Remove the Prefilter Pleated Cartridge Element from the bowl.
3. Remove the O-Ring from the top of the bowl. The O-Ring is fragile, so handle it with care.
4. Replace the Prefilter Pleated Cartridge Element with a new Sea Recovery element.
5. Wipe the O-Ring with a damp cloth.
6. Lubricate the O-Ring lightly using a sparingly amount of O-Ring lubricant.
7. Place the O-Ring back onto the bowl.
8. Insert the cleaned or new Sea Recovery Prefilter Pleated Cartridge Element into the bowl.
9. Screw the bowl on clockwise.
10. Hand snug to seal the O-Ring; do not use a wrench or other tool to tighten; do not over tighten. Over tightening may damage the threads in the bowl or housing and cause removal to be difficult.

Low Pressure Gauge [7]

If the pressure gauge fails to register the orifice may be corroded with debris. Use a thin wire or small diameter (1/64th" / 0.4 mm) drill bit to dislodge any debris trapped within the pressure port orifice. If clearing the orifice does not bring the gauge to normal operation, then replace the gauge.

Brine Discharge Thru Hull Fitting [1]

Non Sea Recovery component. Keep the Brine Discharge Thru Hull Fitting free and clear of debris and corrosion.

Aqua Mini 350/550/750 Booster Pump with 1/2 Horse Power Electric Motor

Booster Pump Disassembly

1. Disconnect Power Source to motor.
2. Disconnect electrical connections tagging wires carefully to preserve correct rotation.
3. Remove pump and motor assembly to repair area
4. Remove bolts and volute cover from pump.
5. Remove impeller locknut and impeller. Unscrew CCW.

6. Remove seal head from the shaft. Slide from the shaft.
7. Remove four motor bolts and volute bracket from motor.
8. Remove seal seat from bracket.

Booster Pump Reassembly

1. Clean seat cavity of the volute bracket thoroughly.
2. Thoroughly clean pump shaft. Assure that the shaft is not grooved and that there is no evidence of pitting or fretting. If the shaft is grooved, fretted, or worn, replace it.
3. Install the pump shaft onto the motor shaft. Ensure all debris and burrs are removed from the motor shaft.
4. Place the volute bracket on a firm surface with the seat cavity (pump end) up. Then place a small amount of vegetable oil on the seat cup or o-ring seat. Place the seat in the cavity with the polished face up toward the pump end. Evenly push seat into cavity with fingers then gently tap seat into place with a wooden dowel or plastic rod (1 - 1/8" outside diameter / 28 mm). To help ensure the seat is not damaged, place the cardboard disk supplied with the seal over the seat face.
5. Place volute bracket on motor (aligning the base if applicable). Secure volute bracket with four motor bolts.
6. Pull pump shaft forward until shoulder of pump shaft contacts back of volute bracket and slightly snug one setscrew to hold shaft in place.
7. Install seal head assembly
 - a) Lubricate shaft and elastomer with vegetable oil.
 - b) Install rotary seal head onto pump shaft and slide toward seat until carbon face touches seal seat.
 - c) Install seal spring and retainer.
 - d) Thread impeller onto pump shaft ensuring that the spring retainer does not slip between the shoulder of the shaft and the hub of the impeller. Install locknut with small amount of removable loctite. Hold shaft with locking type pliers (vice grips) and tighten impeller locknut.
 - e) Loosen pump shaft setscrew.
 - f) Install new volute cover gasket and mount volute cover. Secure with bolts and tighten evenly.
 - g) Slide pump shaft forward until impeller touches volute cover. Slide shaft back with a screwdriver .010 - .015" (0.254 - 0.381 mm). Tighten pump shaft setscrews. Rotate shaft by hand to ensure impeller does not rub against volute cover.
8. Return pump to installation and reconnect electrical connections.
9. Start pump momentarily to observe shaft rotation. If rotation corresponds to the rotation arrow, pump may be put into service. If rotation is incorrect, refer to the wiring diagrams within this manual.

Chapter 10

System Logs

Sea Recovery Aqua Mini 170,350,550,&750 NEW SYSTEM INITIAL READINGS

At the time of commissioning the NEW system, record the following information after one hour of continuous proper operation of the system. Retain this form in the Owner's Manual for future reference and troubleshooting.

Retain the form in this Owners Manual for the owner and operator's future reference. This information is valuable to the servicing technicians in providing technical support to the owner and future operators of the Aqua Mini 170/350/550/750. Provide this information to service technicians when requesting technical assistance.

Serial Number: _____ Model Number: Aqua Mini 170 _____; or Aqua Mini 350/550/750 _____

Name of Operator: _____ Date: _____

Installer Information:

Company _____

Street Address _____

City, State _____

Country, postal code _____

Telephone number _____

Name of Installer _____

System Power: _____ Volts AC, _____ Hz or _____ Volts DC

Feed Water Temperature: _____ Fahrenheit or _____ Celsius

Hour Meter : _____ Hours

PRESSURE GAUGE

Low Pressure Gauge : _____ psi High Pressure Gauge reading: _____ psi

WATER FLOW METER

Product Water Flow Meter: _____ Gallons Per Hour or _____ Liters Per Hour

WATER QUALITY

Feed Water Salinity: _____ ppm or Location of use: _____

Product Water Salinity: _____ ppm

Unusual occurrences or noises: _____

Sea Recovery AquaMini 170,350,550,& 750 System Identification Information

INSTRUCTIONS: It is important that this form is completely filled in at the time of purchase of the Sea Recovery Aqua Mini 170,350,550,&750 Reverse Osmosis Desalinator. This information will be requested by our Service Department and Parts Order Desk whenever contacting Sea Recovery for technical assistance or by the Sales Department whenever ordering parts.

System Information: Aqua Mini 170/350/550/750

Model Number: _____ Serial Number: _____

Operating Voltage:

Direct Current: ___ 12 VDC or ___ 24 VDC

Alternating Current: ___ 110/115 VAC or ___ 220/230 VAC

Cycles: ___ 50 Hz or ___ 60 Hz

Date Purchased: _____

Date Commissioned: _____

(First tested or operated)

Dealer Information:

Dealer's Name: _____

Address: _____

City: _____ State: _____

Country: _____ Postal Code: _____

Dealer's Invoice Number: _____

Sea Recovery Corporation

P.O. Box 5288

Carson, California 90745-5288 U.S.A.

Tel: 1-310-637-3400 • Fax: 1-310-637-3430

Email: sales@searecovery.com • Web: <http://www.searecovery.com>

Sea Recovery Aqua Mini 170,350,550, & 750 Daily Operation Log System Readings

Make copies of this blank form. At each shut down of the Aqua Mini 170 /350/550/750, record the following information. Retain these daily logs of the system performance for future reference and troubleshooting.

This information is valuable to the servicing technicians in providing technical support to the owner and future operators of the Aqua Mini 170/350/550/750. Provide this information to service technicians when requesting technical assistance.

Serial Number: _____ Model Number: Aqua Mini 170 _____; or Aqua Mini 350/550/750 _____
Name of Operator: _____ Date: _____
System Power: _____ Volts AC, _____ Hz; or ; _____ Volts DC
Feed Water Temperature: _____ Fahrenheit or _____ Celsius
Hour Meter : _____ Hours

PRESSURE GAUGE

Low Pressure Gauge : _____ psi High Pressure Gauge reading: _____ psi

WATER FLOW METER READINGS

Product Water Flow Meter: _____ Gallons Per Hour or _____ Liters Per Hour

WATER QUALITY

Feed Water Salinity: _____ ppm or Location of use: _____

Product Water Salinity: _____ ppm

Unusual occurrences or noises: _____

Chapter 11

Glossary

Terms

Cascading Failure

A failure in a system of interconnected parts in which the failure of a part can trigger the failure of successive parts.

Boundary Layer

(Also known as Concentration Polarization.) When water permeates through the membrane, nearly all the salt is left behind in the brine channel. In any dynamic hydraulic system, the fluid adjacent to the wall of the vessel is moving relatively slow. Even though the main body of the stream is turbulent, a thin film adjacent to the wall (membrane) is laminar. This thin film is called the boundary layer. At the boundary layer the salts are saturated and can readily adhere to and pack into the RO membrane element surface if the Feed Water Flow is insufficient. For this reason, it is important to maintain sufficient Feed Water flow, to prevent Concentration Polarization, through the RO membrane element.

Brine Velocity

The brine flow over the membrane surface is very important to both product water quality and quantity. At low flows, concentration polarization occurs, causing the water quality to decline. In addition to inferior product water quality, low brine flows can increase the precipitation of sparingly soluble salts which will foul the RO membrane element surface (concentration polarization). If this occurs, the product water flux (production) will decline. The Feed Pump integrated design provide a relatively smooth and continual flow of Feed Water across and through the RO membrane element.

Compaction

Some densification of the membrane structure may take place while operating at elevated pressures, above 1000 PSI. The change is known as compaction and is accompanied by a reduction in the water permeation rate. When the RO membrane element is subjected to elevated pressures beyond 1000 PSI the Product Water Channel becomes squeezed which results in restriction and in turn product water recovery reduction.

Osmotic Pressure

The transfer of the water from one side of the membrane to the other will continue until the head (pressure) is great enough to prevent any net transfer of the solvent (water) to the more concentrated (feed water) solution. At equilibrium, the quantity of water passing in either direction is equal, and the head pressure is then defined as the "Osmotic Pressure" of the solution having that particular concentration of dissolved solids.

Pressure

The operating pressure has a direct affect on product water quality and quantity. Both factors will increase as the system pressure increases (higher quantity and higher quality within design limits). The system must be operated at the lowest pressure required to achieve the designed product water flow rate. This parameter also minimizes compaction, which proceeds at a faster rate at higher pressures as well as at higher temperatures. The System self adjusts its operating pressure to maintain a precise amount of Product Water Flow. However in so doing, at low temperatures and or high salinity feed water conditions the system will operate at higher than normal pressure in maintaining the specified amount of product water flow. This is normal, to be expected, and is due to the design characteristics of the system.

Spiral-Wound Membrane

The spiral-wound membrane consists of multiple membrane envelopes each formed by enclosing a channelized product water carrying material between two large flat membrane sheets. The membrane envelope is sealed on three edges with a special adhesive and attached with the adhesive to a small diameter pipe. A polypropylene screen is used to form the feed water channel between the membrane envelopes. A wrap is applied to the membrane element to maintain the cylindrical configuration. The center tube is also the permeate (product water) collecting channel. Several elements may be connected in series within a single or multiple pressure vessels).

Water Temperature Effect

The product water flow through the membrane is significantly affected by the water temperature. At any given pressure this flow increases with increasing water temperature and is reduced at lower temperatures. The System over comes this factor by self adjusting the operating pressure to maintain a precise amount of Product Water Flow.

Chapter 12

Exploded Parts View

A041C AQUA MINI 170

ITEM NO.	QTY.	PART NUMBER	DESCRIPTION
1	1	B156220110	HP PUMP-MOTOR 110-220-56 AW 170
2	1	B196220017	MEMBRANE VESSEL ASSY AS 170
3	1	B502220003	MANIFOLD LP ASSY
4	1	B502230003	CONTROL MANIFOLD ASSY, MINIS (2012)
5	1	B586220003	FRAME ASSY AQUA MINI 170 (2012)
6	1	B595320007	CONTROLLER 110-220V AW MINI (2012)
7	4	061100043000	WASHER,FLAT,OS,1/4",SS
8	4	061142145012	BOLT HEX .25-20 X .75 SS
9	3	061160630012	SC PHIL PAN 10-24 X .75 SS

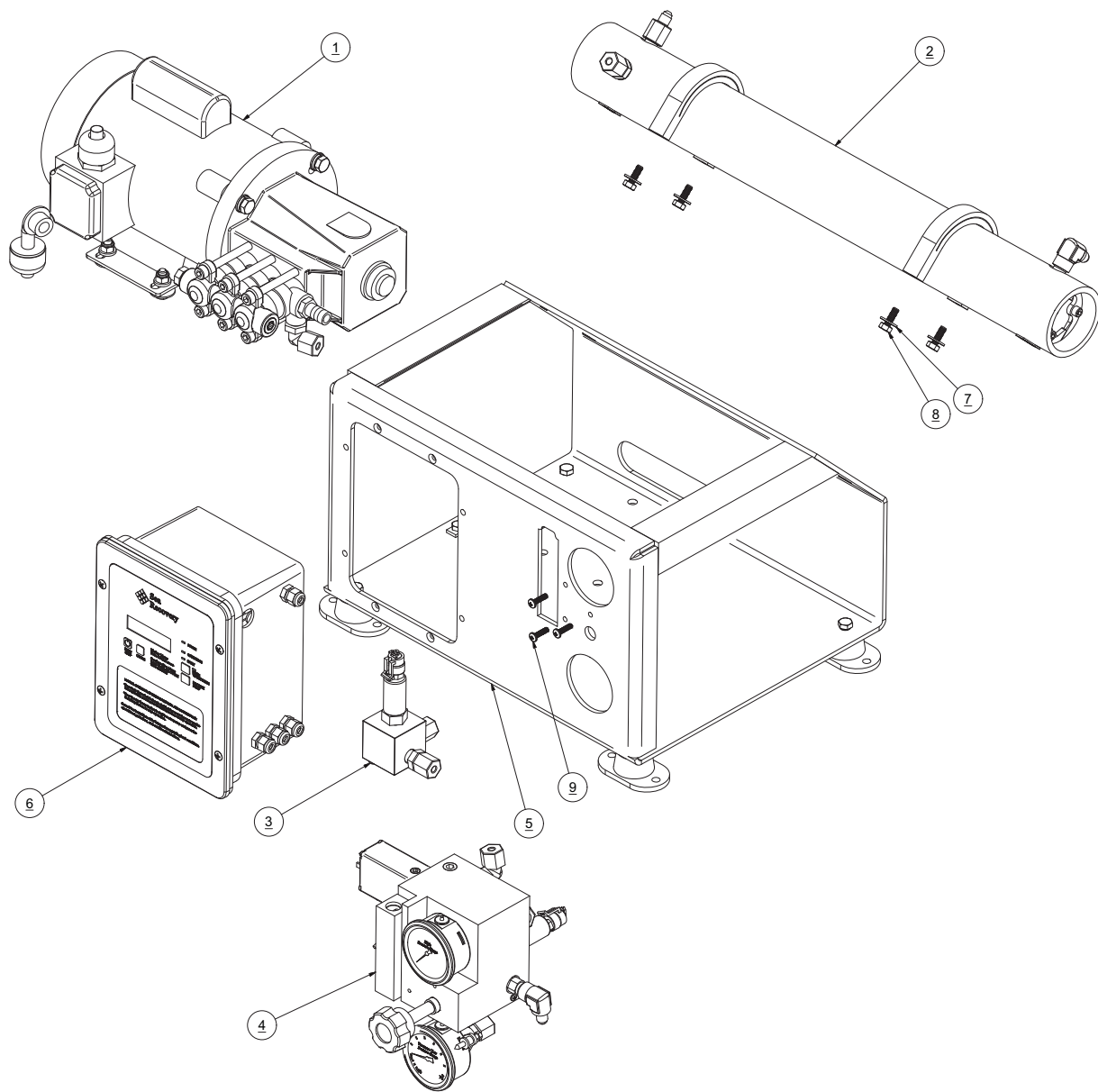

A051C AQUA MINI 350

ITEM NO.	QTY.	PART NUMBER	DESCRIPTION
1	1	B107230001	PREFILTER ASSY DUAL 350
2	1	B156230003	HP PUMP-MOTOR 110-220 50-60 1PH
3	1	B196230001	MEMBRANE VESSEL ASSY AW 350
4	1	B502220003	MANIFOLD LP ASSY
5	1	B502230003	CONTROL MANIFOLD ASSY, MINIS (2012)
6	1	B586230003	FRAME ASSY, MINI 350 (2012)
7	1	B595320007	CONTROLLER 110-220V AW MINI (2012)
8	4	061100043000	WASHER,FLAT,OS,1/4",SS
9	4	061142145012	BOLT HEX .25-20 X .75 SS
10	3	061160630012	SC PHIL PAN 10-24 X .75 SS

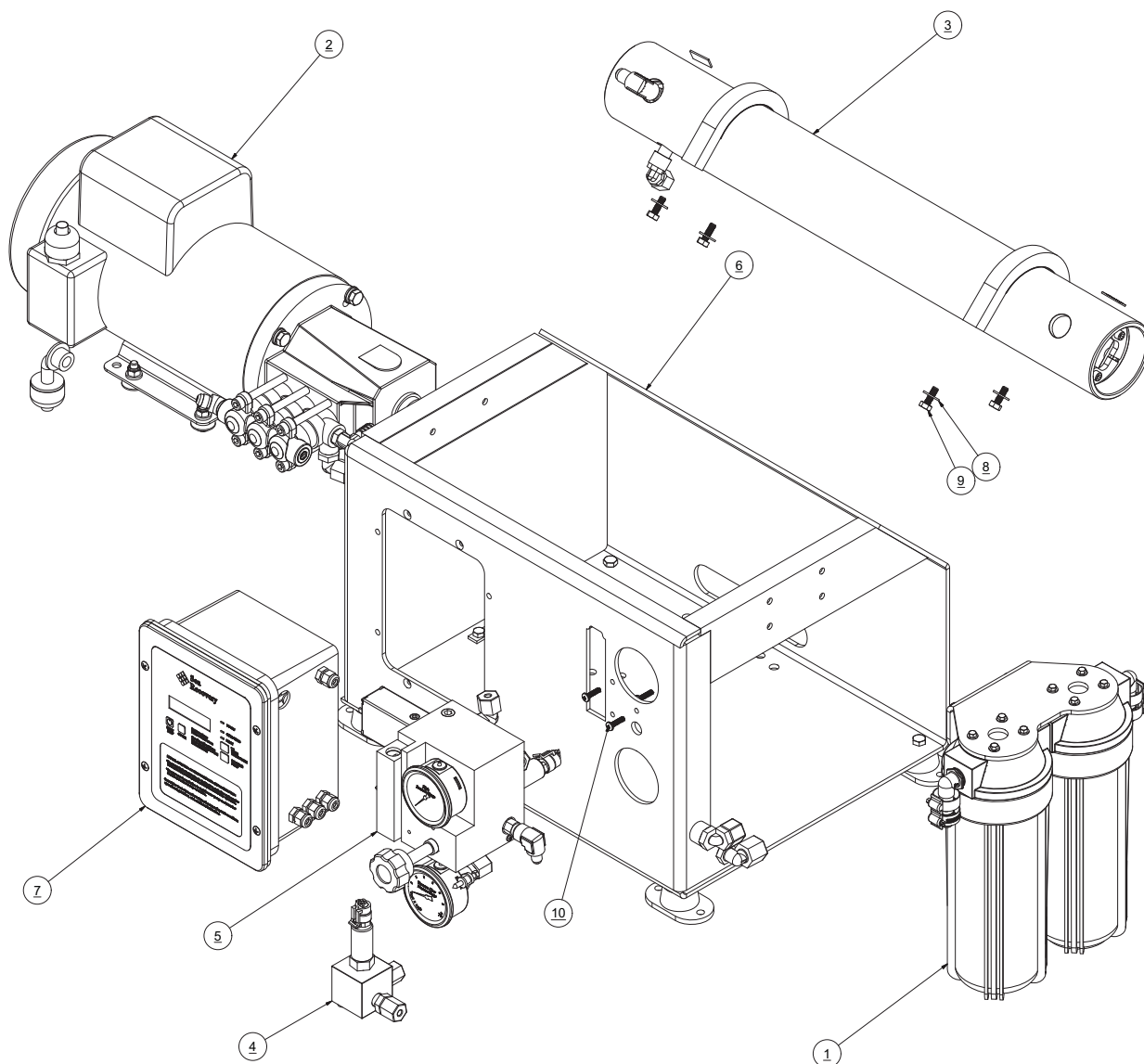

A051C AQUA MINI 550

ITEM NO.	QTY.	PART NUMBER	DESCRIPTION
1	1	B107230002	BRACKET MNT SADDLE UV-AW TOP
2	1	B156230003	BRACKET MNT SADDLE UV-AW BTM
3	1	B196230002	MEMBRANE RACK ASSY AW-SF 500-1
4	1	B502220002	MANIFOLD LP ASSY
5	1	B502230002	CONTROL MANIFOLD ASSY, MINIS (2012)
6	1	B586230003	FRAME ASSY, MINI 350 (2012)
7	1	B595320007	CONTROLLER 110-220V AW MINI (2012)
8	4	061100043000	WASHER,FLAT,OS,1/4",SS
9	4	061142145012	BOLT HEX .25-20 X .75 SS
10	3	061160630012	SC PHIL PAN 10-24 X .75 SS

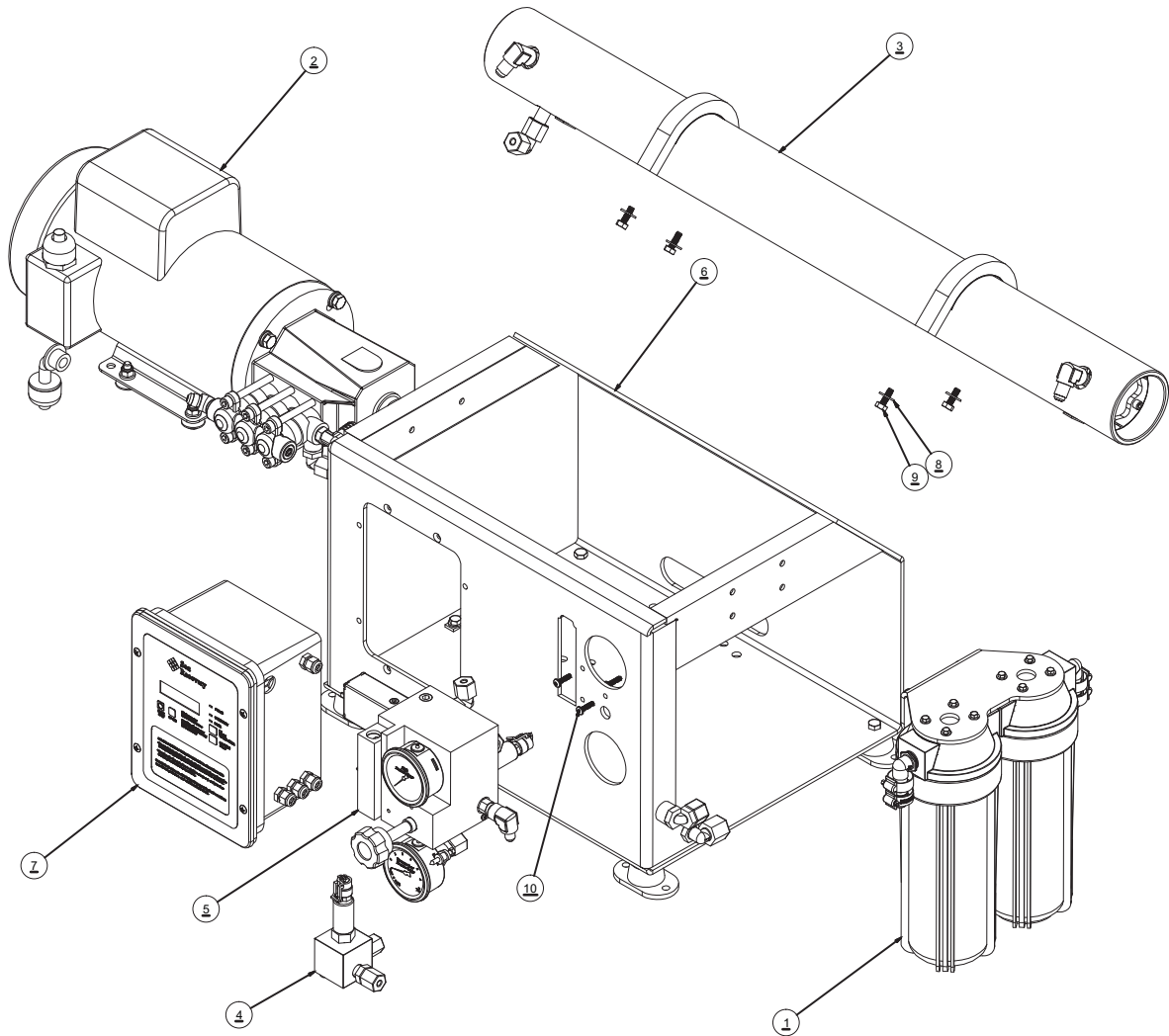

A051C AQUA MINI 750

ITEM NO.	QTY.	PART NUMBER	DESCRIPTION
1	1	B107230001	PREFILTER ASSY DUAL 350
2	1	B156230003	HP PUMP-MOTOR 110-220 50-60 1PH
3	1	B196230003	MEMBRANE RACK ASSY AW-SF 750-1
4	1	B502220003	MANIFOLD LP ASSY
5	1	B502230003	CONTROL MANIFOLD ASSY, MINIS (2012)
6	1	B586230003	FRAME ASSY, MINI 350 (2012)
7	1	B595320007	CONTROLLER 110-220V AW MINI (2012)
8	4	061100043000	WASHER,FLAT,OS,1/4",SS
9	4	061142145012	BOLT HEX .25-20 X .75 SS
10	3	061160630012	SC PHIL PAN 10-24 X .75 SS

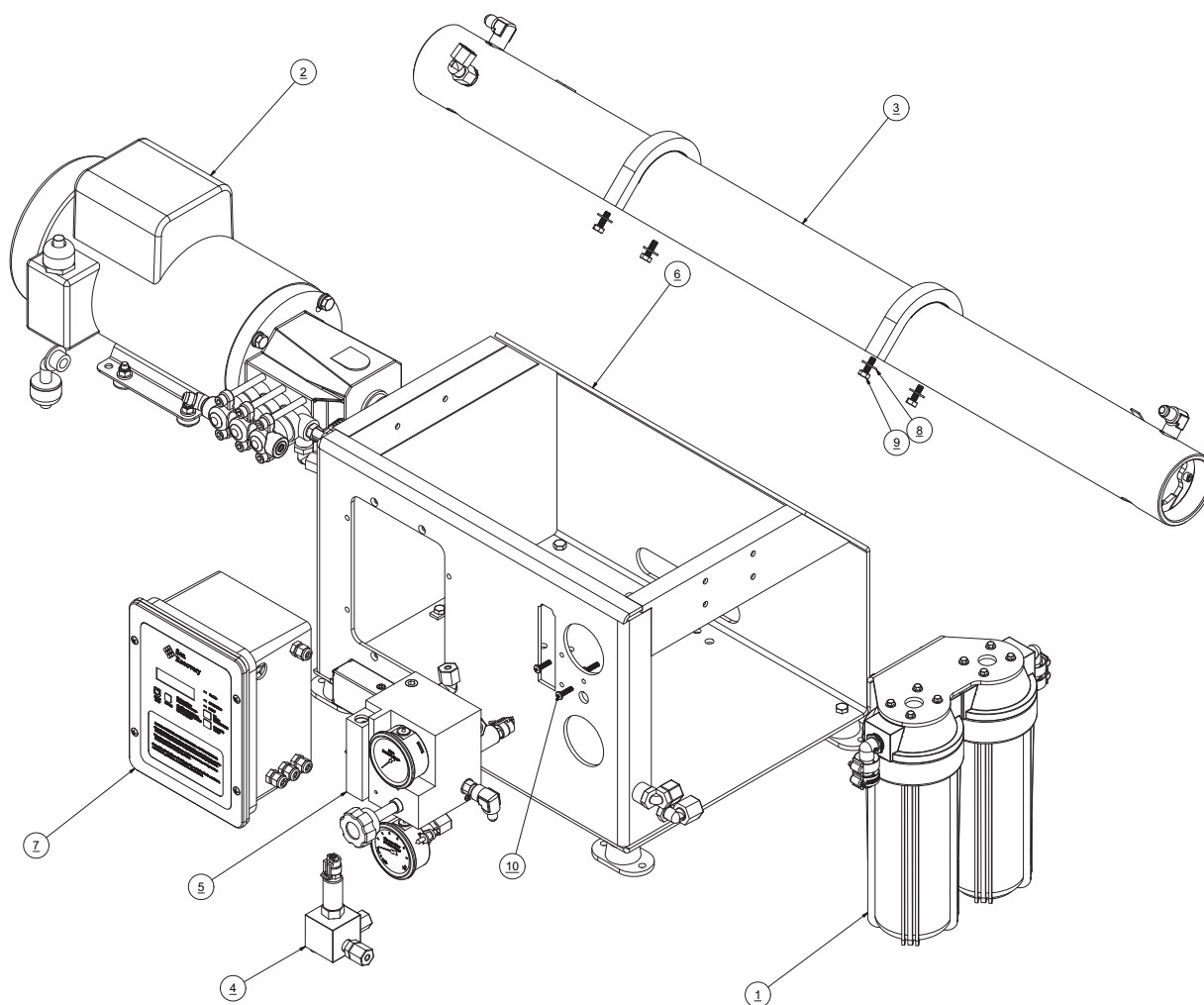

A052M AQUA MINI MODULAR

ITEM NO.	QTY.	PART NUMBER	DESCRIPTION
1	1	B586510002	FRAME ASSY, MINI MODULAR
2	1	B502220003M	MANIFOLD LP ASSY
3	1	B502230003M	CONTROL MANIFOLD ASSY, MINIS
4	1	B595320007	CONTROLLER 110-220V AW MINI
5	1	B156230004M	HP PUMP-MOTOR 110-220 50-60 AW 550-750 1PH
6	1	B196230002	MEMBRANE RACK ASSY AW-SF 500-1
7	1	B107230001	PREFILTER ASSY DUAL 350
8	4	061142145012	BOLT HEX .25-20 X .75 SS
9	3	061160630012	SC PHIL PAN 10-24 X .75 SS
10	4	061100043000	WASHER,FLAT,OS,1/4",SS

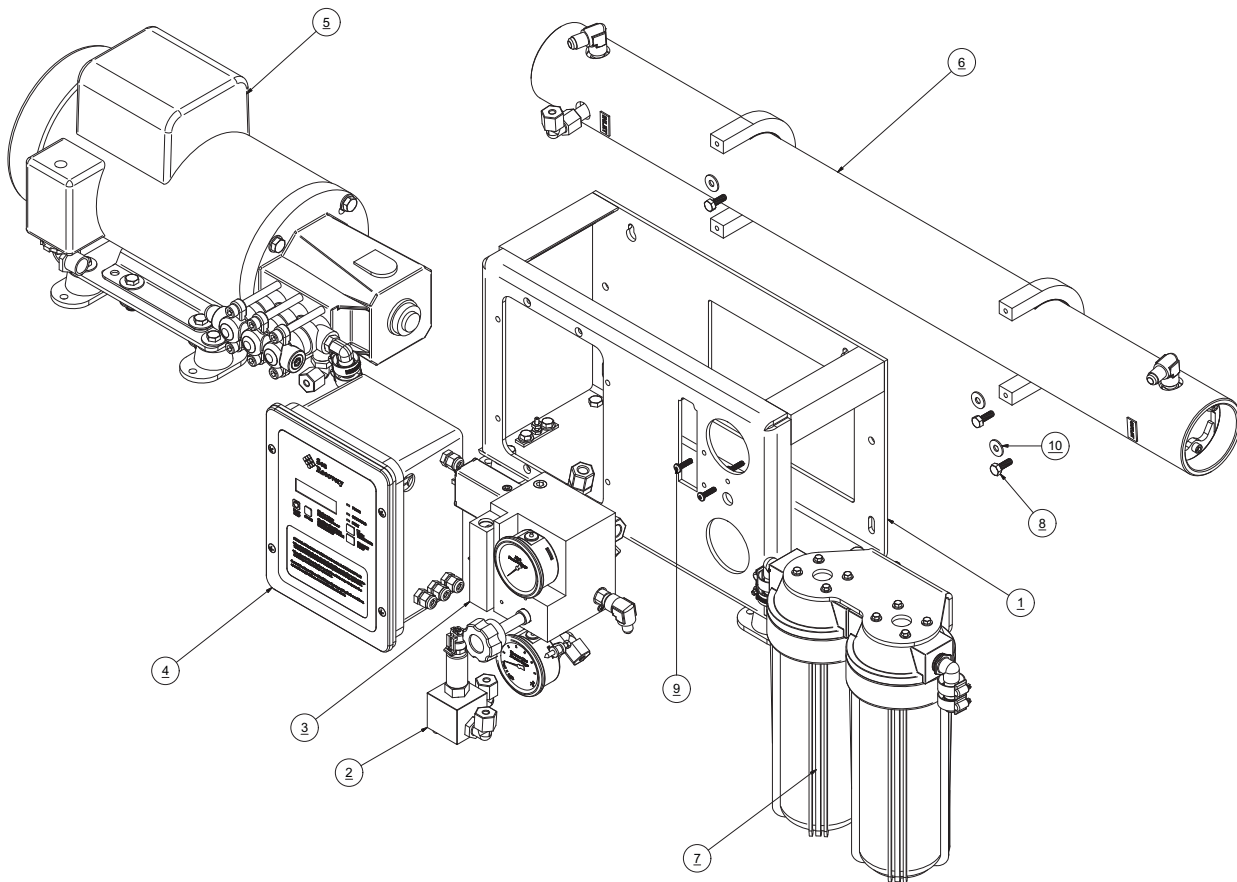

BOOSTER PUMP ASSY AW 170

ITEM NO.	QTY.	PART NUMBER	DESCRIPTION
2	2	0112651900	ADAP .375 MPT X .50 BARB NYLON
3	4	061170628020	SC PHIL PAN A #10 X 1.25 SS
4	4	065080028000	WASHER FLAT #10 NYLON

PART NUMBER: B016220001 BOOSTER PUMP ASSY AW170 12VDC

ITEM NO.	QTY.	PART NUMBER	DESCRIPTION
1	1	12124001SF	BOOSTER PUMP/MOTOR 170-12VDC

PART NUMBER: B016220002 BOOSTER PUMP ASSY AW170 12VDC

ITEM NO.	QTY.	PART NUMBER	DESCRIPTION
1	1	12124002SF	BOOSTER PUMP/MOTOR 170-24VDC

PART NUMBER: B016220003 BOOSTER PUMP ASSY AW170 110V

ITEM NO.	QTY.	PART NUMBER	DESCRIPTION
1	1	12124003SF	BOOSTER PUMP/MOTOR 170-115VAC

PART NUMBER: B016220004 BOOSTER PUMP ASSY AW170 220VAC

ITEM NO.	QTY.	PART NUMBER	DESCRIPTION
1	1	12124004SF	BOOSTER PUMP/MOTOR 170-220VAC

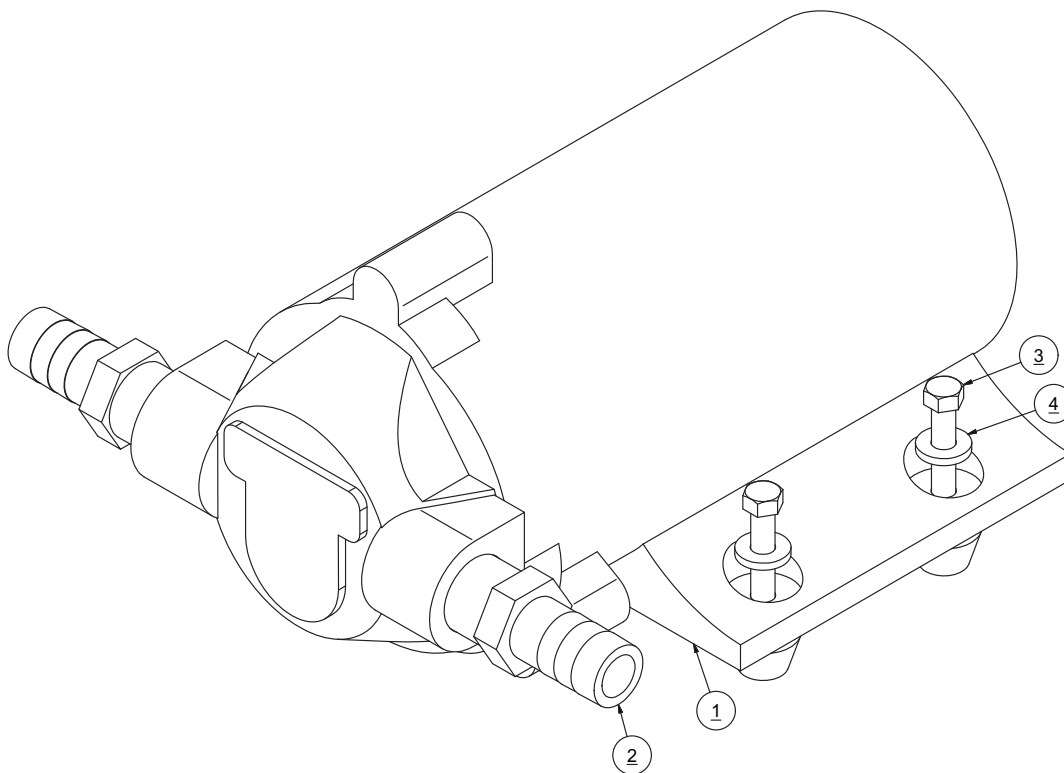

B016230003 BOOSTER PUMP ASSY 350 HP75 W- 4.75 IN IMPELLER

ITEM NO.	QTY.	PART NUMBER	DESCRIPTION
1	1	1205514772	BOOSTER PUMP HEAD HP75 W-4.75 IN IMPELLER
2	1	1519081110	MOTOR .50 HP 110-230-50-60-1PH
3	1	1920023632	STRAIN RELIEF 90 CG90-6250
4	1	0112653700	ADAP .75 MPT X.75 BARB NYLON
5	1	01120737DG	ELB90 .75 MPT X .75 BARB NYLON
6	4	061172143016	SCREW,HEX A.,.25x1.00,SS
7	1	063200066000	NUT LOCK .50 STEEL
8	4	061142157016	SCREW,HEX HEAD,3/8-16x1",SS
9	4	061080056000	WASHER,FLAT,3/8",SS
10	4	061100043000	WASHER,FLAT,OS,1/4",SS

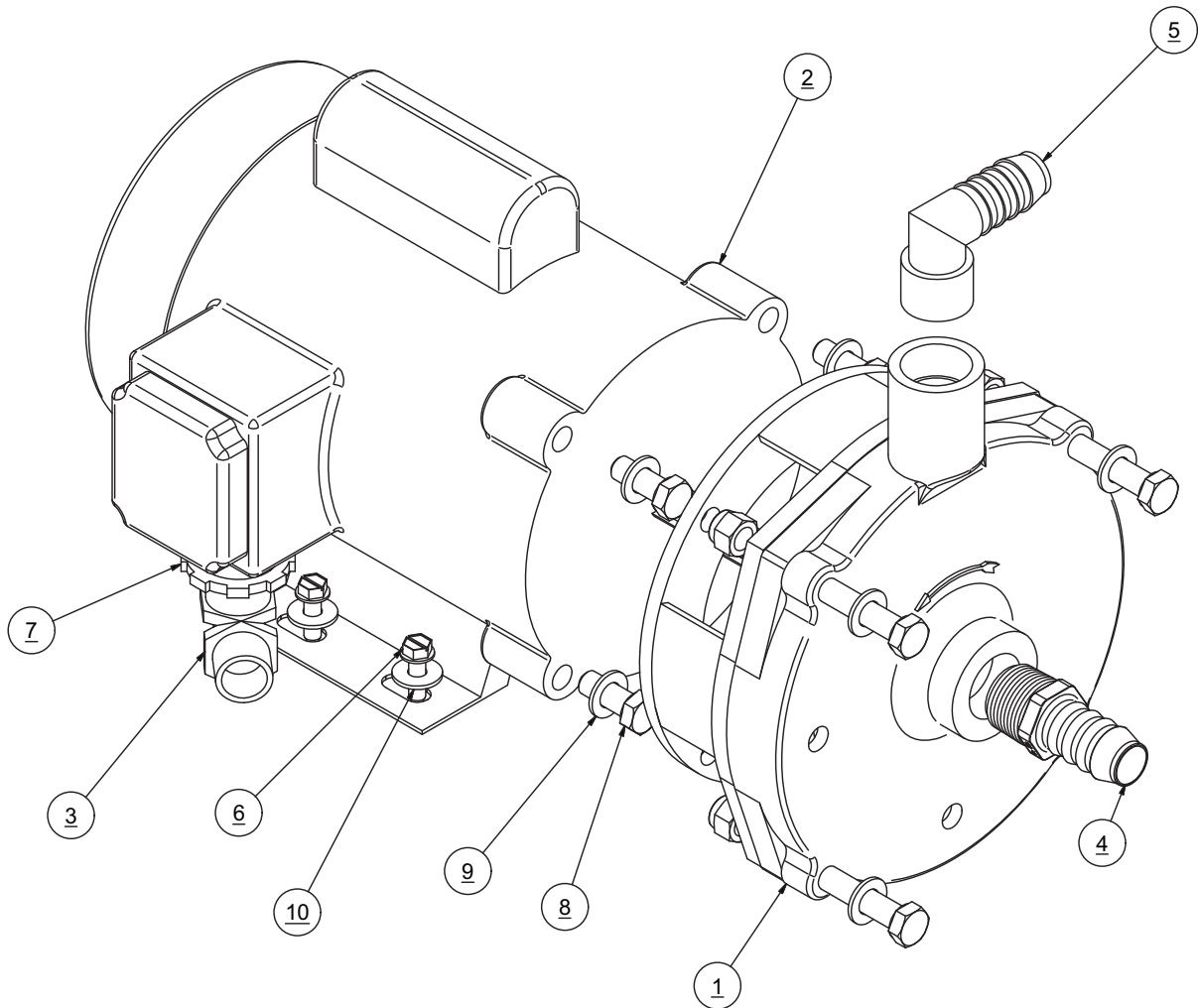

B196220017 MEMBRANE VESSEL ASSY 170

ITEM NO.	QTY.	PART NUMBER	DESCRIPTION
1	2	05202402GR	BRACKET MVA U-CLAMP
2	1	2453487000	END PLUG SINGLE 2.5 AW 170
3	1	2453497000	END PLUG 2.5 AW 170
4	1	2408132026	VESSEL 170 AW
5	1	2724010633	MEMBRANE VESSEL ASSY AW 170
6	2	0520210500	RETAINER PORT MVA AW 170
7	2	20201022000	SEGMENT RING AW 170
8	2	2615180100	FELT ADHESIVE 0.125 X 0.75 STRIP
9	2	0117410801	HP NIPPLE, MVA, AW 170
10	1	0204090869	FITTING,PP,1/4 ODx1/4 MT
11	1	1317010869	ELB90 -4 FLARE X .25 FPT SS
12	1	1317120869	CONN -4 FLARE X .25 FPT SS
13	6	061162345012	SC SOC CAP .25-20 X .75 SS
14	4	2614010100	O-RING 116 PRODUCT AS-AW
15	4	2614010200	O-RING 227 SEAL 2.50
16	4	2614017100	O-RING 111 SALINITY PRB-BPR CS
17	1	2213017063	LABEL INLET (WHITE BACKGROUND)
18	1	2213017163	LABEL OUTLET (WHITE BACKGROUND)

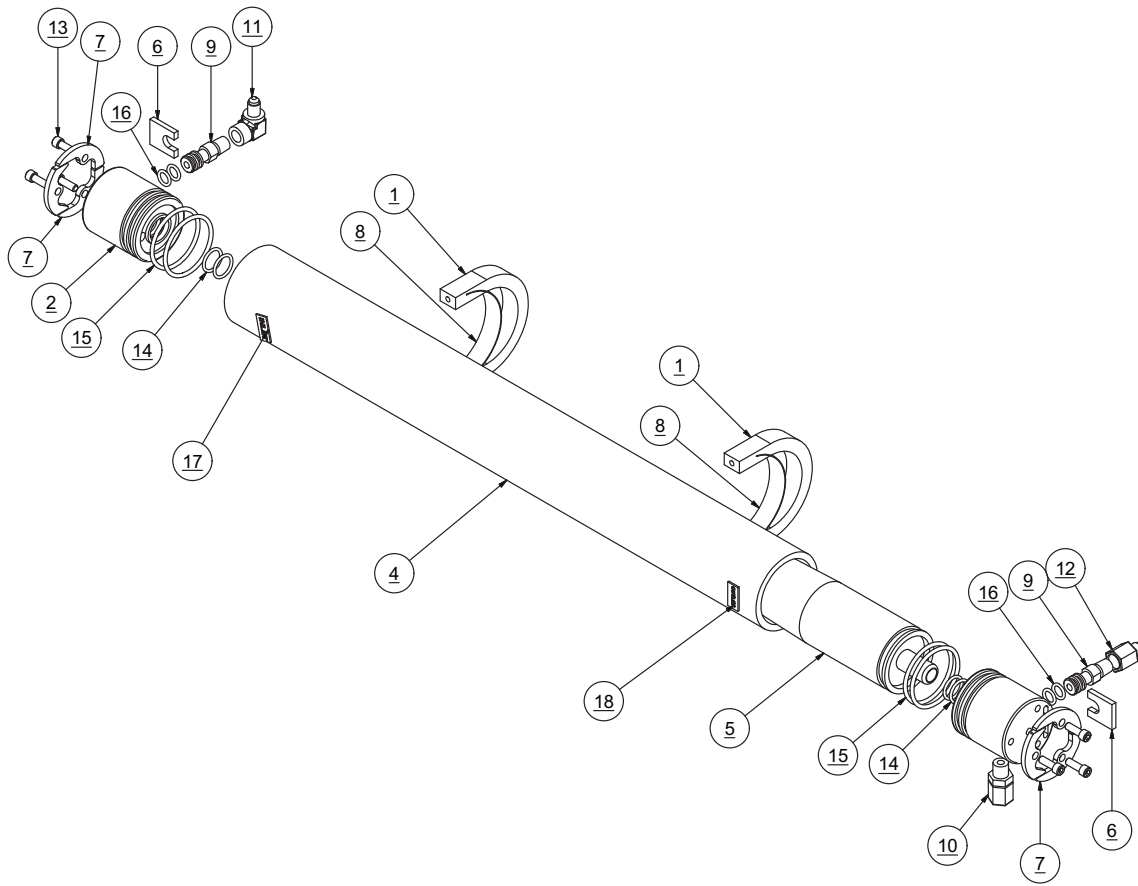

MEMBRANE VESSEL ASSY AW 350-750

ITEM NO.	QTY.	PART NUMBER	DESCRIPTION
1	2	05202401GR	BRACKET,MVA U-CLAMP,3 IN
2	1	2453502400	END PLUG SINGLE 3 AW
3	2	0520210600	RETAINER PORT MVA
6	2	2615180100	FELT ADHESIVE 0.125 X 0.75 STRIP
7	1	2453512400	END PLUG DUAL 3 IN AW
8	1	0204010869	ELB90 .25 TUBE x .25 FNPT PLASTIC
9	2	1317011769	ELB90 6 FLARE X .25 FPT SS
10	1	0101370815	NIPPLE 0.25 NPT x 1.50
11	2	0117410800	NIPPLE HP MVA AW
12	2	2614010100	O-RING 116 PRODUCT AS-AW
13	4	2614014900	O-RING 230 BRINE 3.0 END PLUG
14	4	2614017900	O-RING 115 INTERCONNECT AW
15	6	061162345012	SC SOC CAP .25-20 X .75 SS
16	2	20201030000	SEGMENT RING AW (SET)
17	1	2213017063	LABEL INLET (WHITE BACKGROUND)
18	1	2213017163	LABEL OUTLET (WHITE BACKGROUND)

PART NUMBER: B196230001 MEMBRANE VESSEL ASSY AW-SF 350

ITEM NO.	QTY.	PART NUMBER	DESCRIPTION
4	1	2408132500	VESSEL HIGH PRESSURE 450GPD
5	1	2724011233	MEMBRANE 450GPD AW W-SEAL

PART NUMBER: B196230002 MEMBRANE RACK ASSY AW-SF 500

ITEM NO.	QTY.	PART NUMBER	DESCRIPTION
4	1	2408132500-01	VESSEL HIGH PRESSURE 700GPD
5	1	2724011333	MEMBRANE 700GPD AW W-SEAL

PART NUMBER: B196230003 MEMBRANE RACK ASSY AW-SF 750

ITEM NO.	QTY.	PART NUMBER	DESCRIPTION
4	1	2408132500-02	VESSEL HIGH PRESSURE 900GPD
5	1	2724011433	MEMBRANE 900 GPD AW W-SEAL

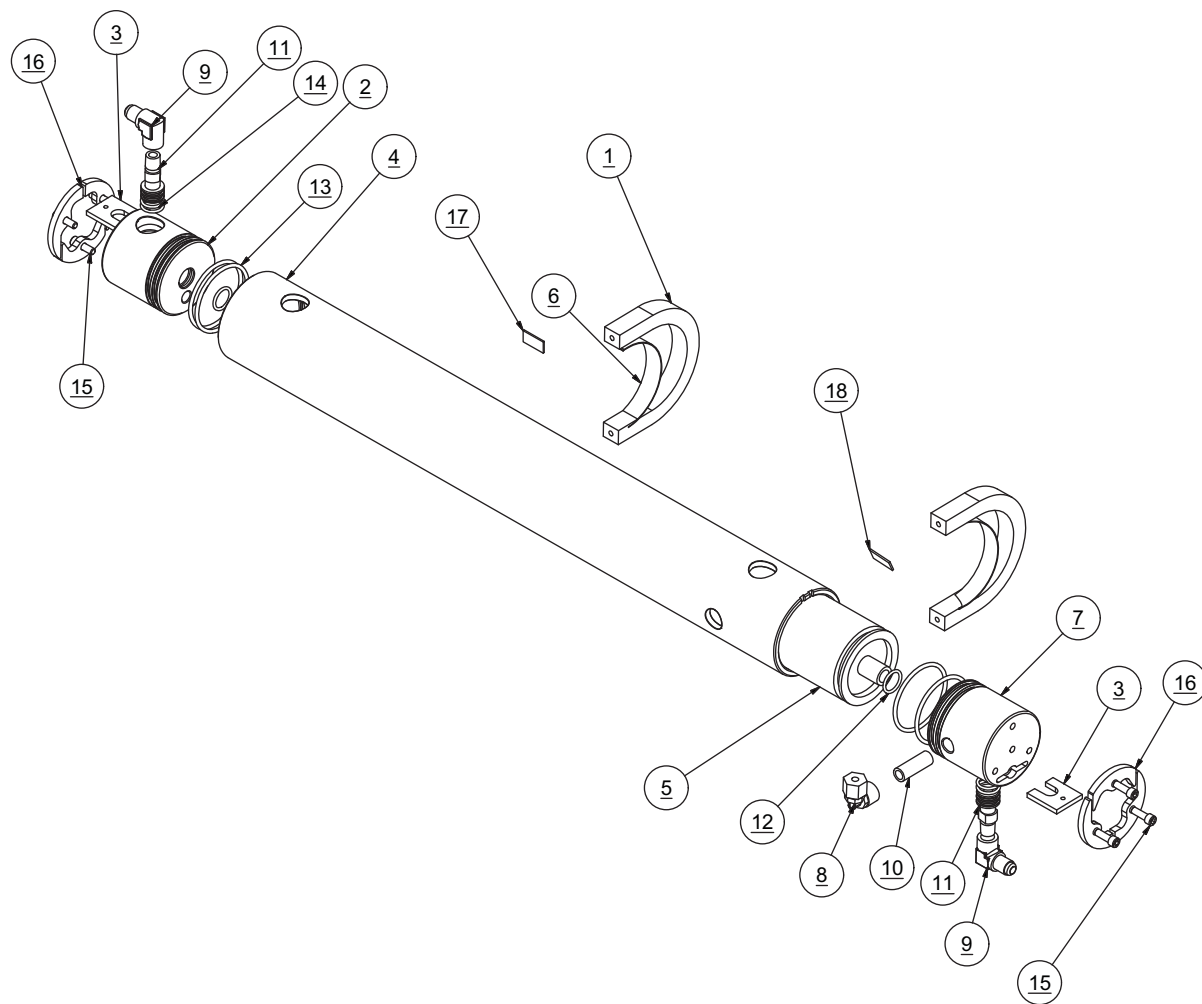

Anatomy of a Spiral Wound Reverse Osmosis Membrane Element

ANATOMY OF A SPIRAL WOUND REVERSE OSMOSIS MEMBRANE ELEMENT

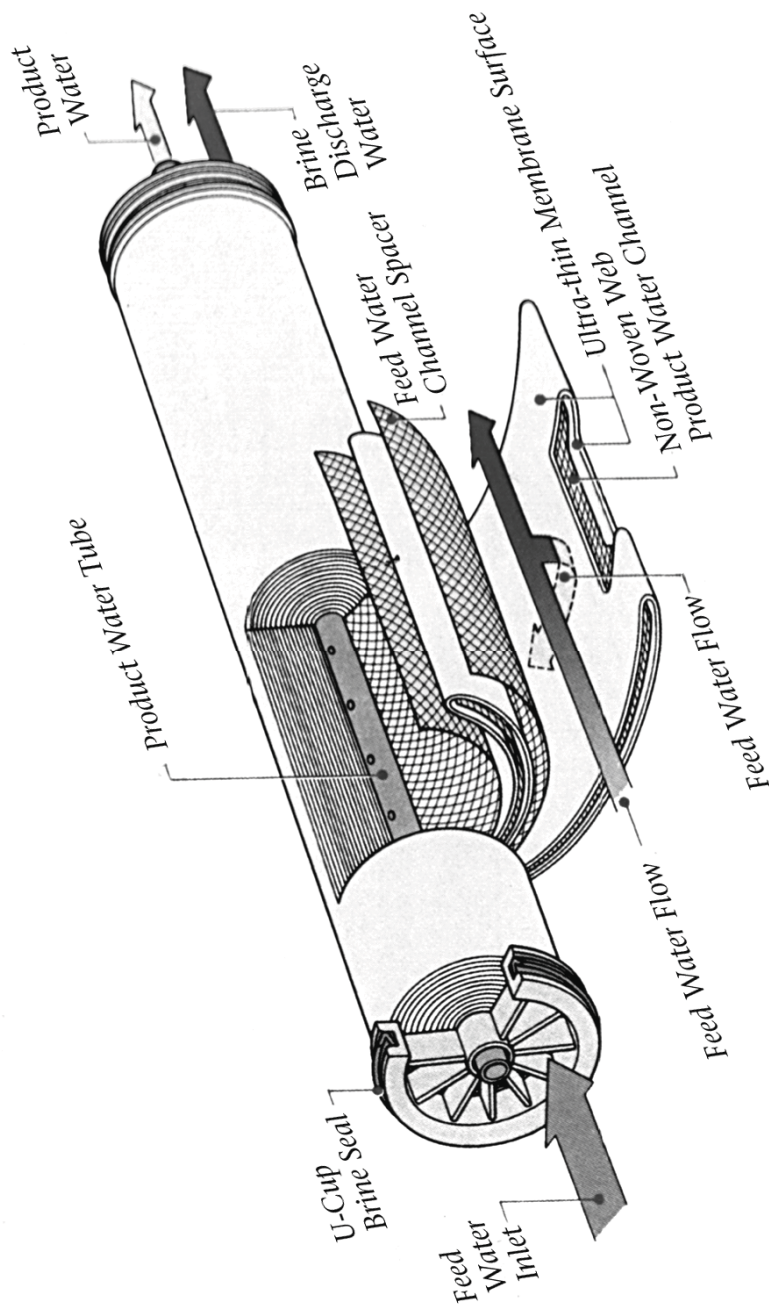

HP PUMP-MOTOR 12VDC-24VDC AW

Mini 170

ITEM NO.	QTY.	PART NUMBER	DESCRIPTION
1	1	1218181422	HP PUMP 0.5 GPM SS CAT
3	1	0112651900	ADAP .375 MPT X .50 BARB NYLON
4	1	0204020869	ELBOW,PP,1/4 ODx1/4 MT
5	1	0117291700	RB .375 MT X .25 FT SS
6	1	1317060800	ELB45 -4 FLARE X .25 MPT SS
7	2	05181434AA	HOSE CLAMP .75 SS
8	1	1904010043	STRAIN RELIEF 3217 .50 IN GREY
9	4	061060050000	NUT HEX .31-18 W-INSERT SS
10	1	0117341869	PLUG .375 MNPT SS
11	4	061142150016	SCREW,HEX HEAD,.31-18x1.00,SS
12	4	061142157024	SCREW,HEX HEAD,3/8-16x1-1/2",SS
13	4	061080056000	WASHER,FLAT,3/8",SS
14	4	061100049000	WASHER,FLAT,OS,5/16",SS
15	4	061120056000	WASHER,LOCK,3/8",SS

B156220012 HP PUMP-MOTOR 12VDC

ITEM NO.	QTY.	PART NUMBER	DESCRIPTION
2	1	15093110CF	MOTOR .33HP 12 VDC

B156220024 HP PUMP-MOTOR 24VDC

ITEM NO.	QTY.	PART NUMBER	DESCRIPTION
2	1	15103210CF	MOTOR .33HP 24 VDC

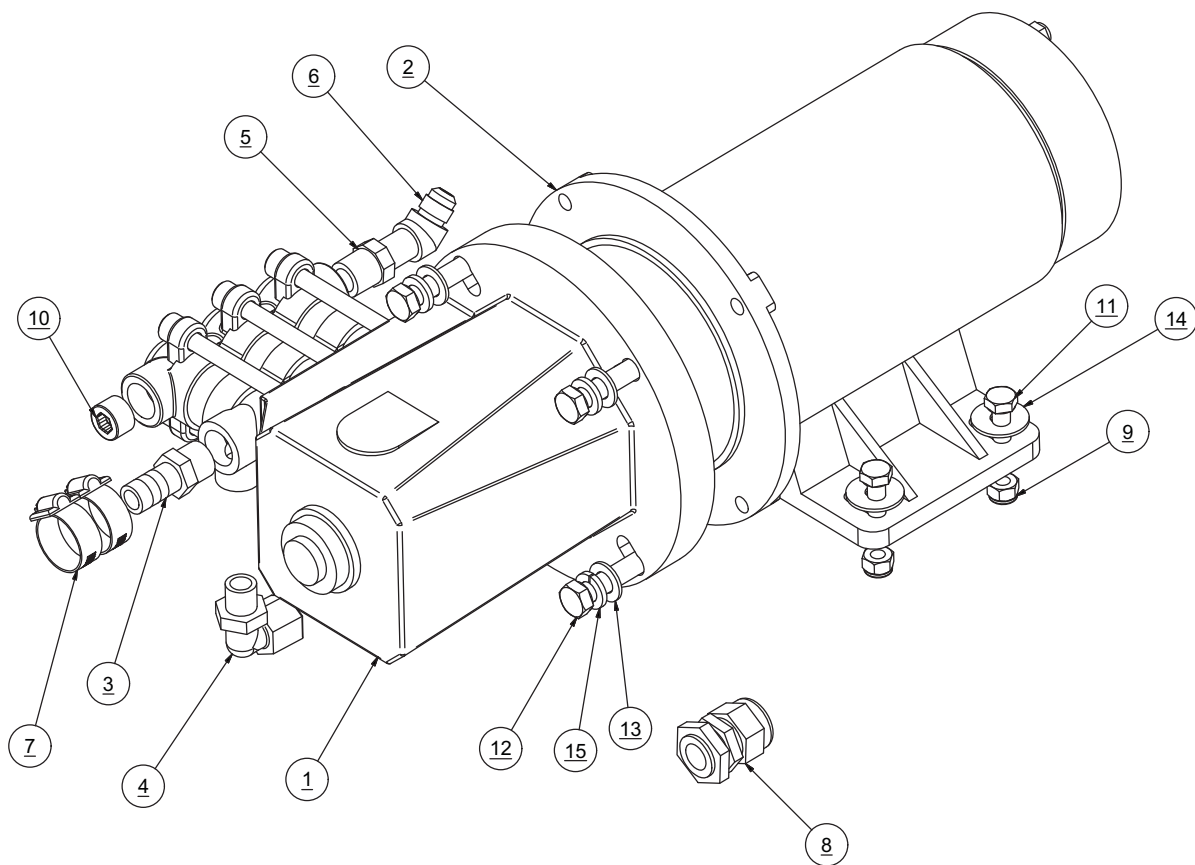
**RECOMMENDED SPARES:**

QTY.	PART NUMBER	DESCRIPTION
1	B653220001	HPP -C SEAL KIT
1	B654220001	HPP -C INLET VALVE REBUILD KIT
1	B652220001	HPP -C PMP KIT SEALS/VALVES

B156220110 HP PUMP-MOTOR 110-220 50-60 AW 170

ITEM NO.	QTY.	PART NUMBER	DESCRIPTION
1	1	1218181422	HP PUMP 0.5 GPM SS CAT
2	1	15AG250912	MOTOR .33 HP 50-60-1
3	1	0112651900	ADAP .375 MPT X .50 BARB NYLON
4	1	0204020869	ELBOW,PP,1/4 ODx1/4 MT
5	1	0117291700	RB .375 MT X .25 FT SS
6	1	1317060800	ELB45 -4 FLARE X .25 MPT SS
7	2	05181434AA	HOSE CLAMP .75 SS
8	4	061060050000	NUT HEX .31-18 W-INSERT SS
9	1	0117341869	PLUG .375 MNPT SS
10	4	061142150016	SCREW,HEX HEAD,.31-18x1.00,SS
11	4	061142157024	SCREW,HEX HEAD,3/8-16x1-1/2",SS
12	1	1904010543	STRAIN RELIEF 8400
13	1	1904013543	STRAIN RELIEF 8423
14	4	061080056000	WASHER,LOCK,3/8",SS
15	4	061100049000	WASHER,FLAT,OS,5/16",SS

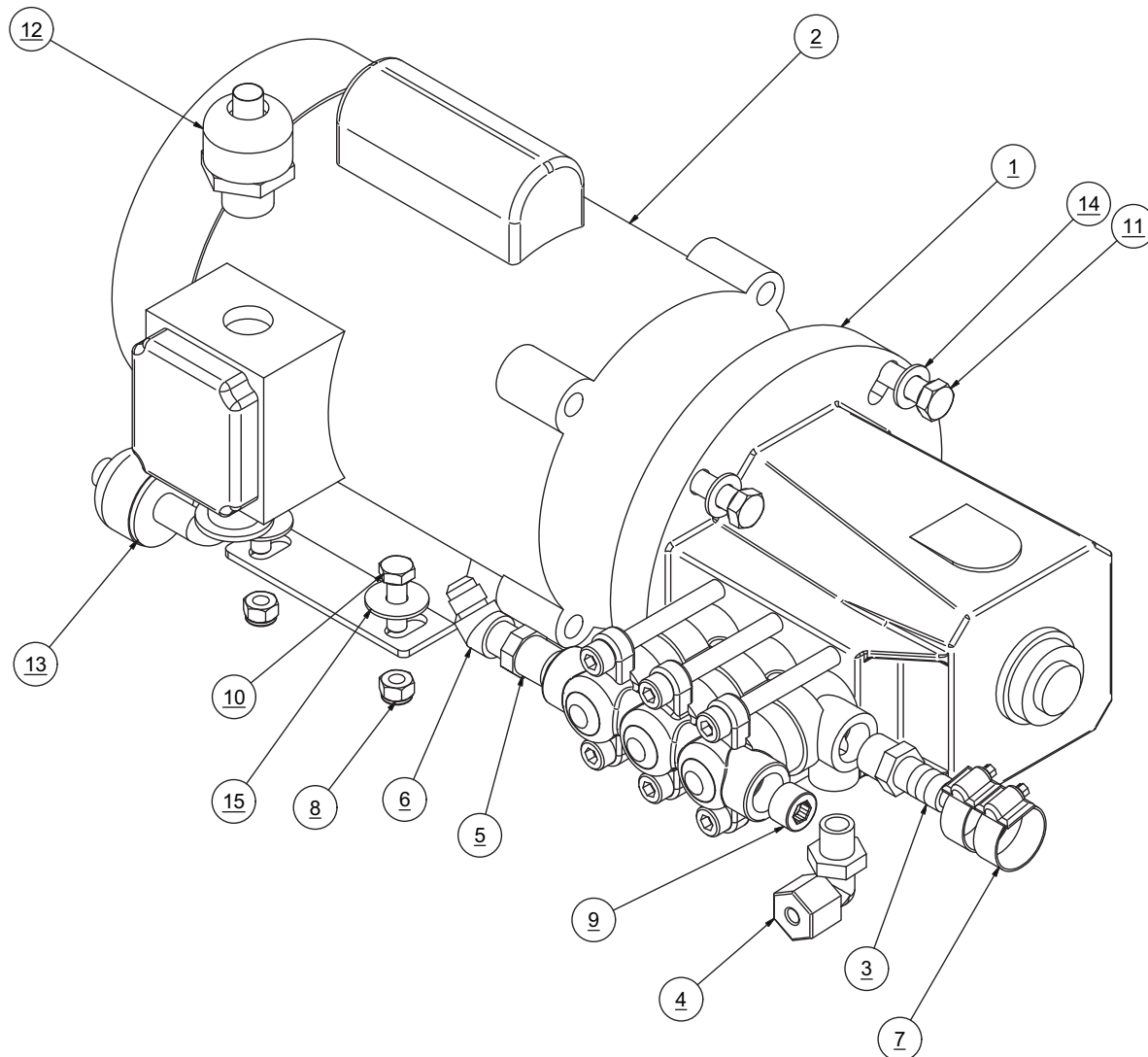
**RECOMMENDED SPARES:**

QTY.	PART NUMBER	DESCRIPTION
1	B653220001	HPP -C SEAL KIT
1	B654220001	HPP -C INLET VALVE REBUILD KIT
1	B652220001	HPP -C PMP KIT SEALS/VALVES

B156230003 HP PUMP-MOTOR 110-220 50-60 1PH

Mini 350, 550, & 750

ITEM NO.	QTY.	PART NUMBER	DESCRIPTION
1	1	12180522CO	HP PUMP GP 2.85 GPM
2	1	15AD062412	MOTOR 2.1 HP 50-60 110-220 1PH
3	1	0112021800	ELB90 .375 MNPT x .62 BARB NYLON
4	1	0204020869	ELBOW,PP,1/4 ODx1/4 MT
5	1	1317061900	ELB45-6 FLARE X 3-8 MT SS
6	1	0117341869	PLUG .375 MNPT SS
7	4	061060050000	NUT HEX .31-18 W-INSERT SS
8	4	061080056000	WASHER,FLAT,3/8",SS
9	4	061100049000	WASHER,FLAT,OS,5/16",SS
10	8	061120056000	WASHER,LOCK,3/8",SS
11	4	061142150016	SCREW,HEX HEAD,.31-18x1.00,SS
12	4	061142157024	SCREW,HEX HEAD,3/8-16x1-1/2",SS
13	1	1904010543	STRAIN RELIEF 8400
14	1	1904013543	STRAIN RELIEF 8423

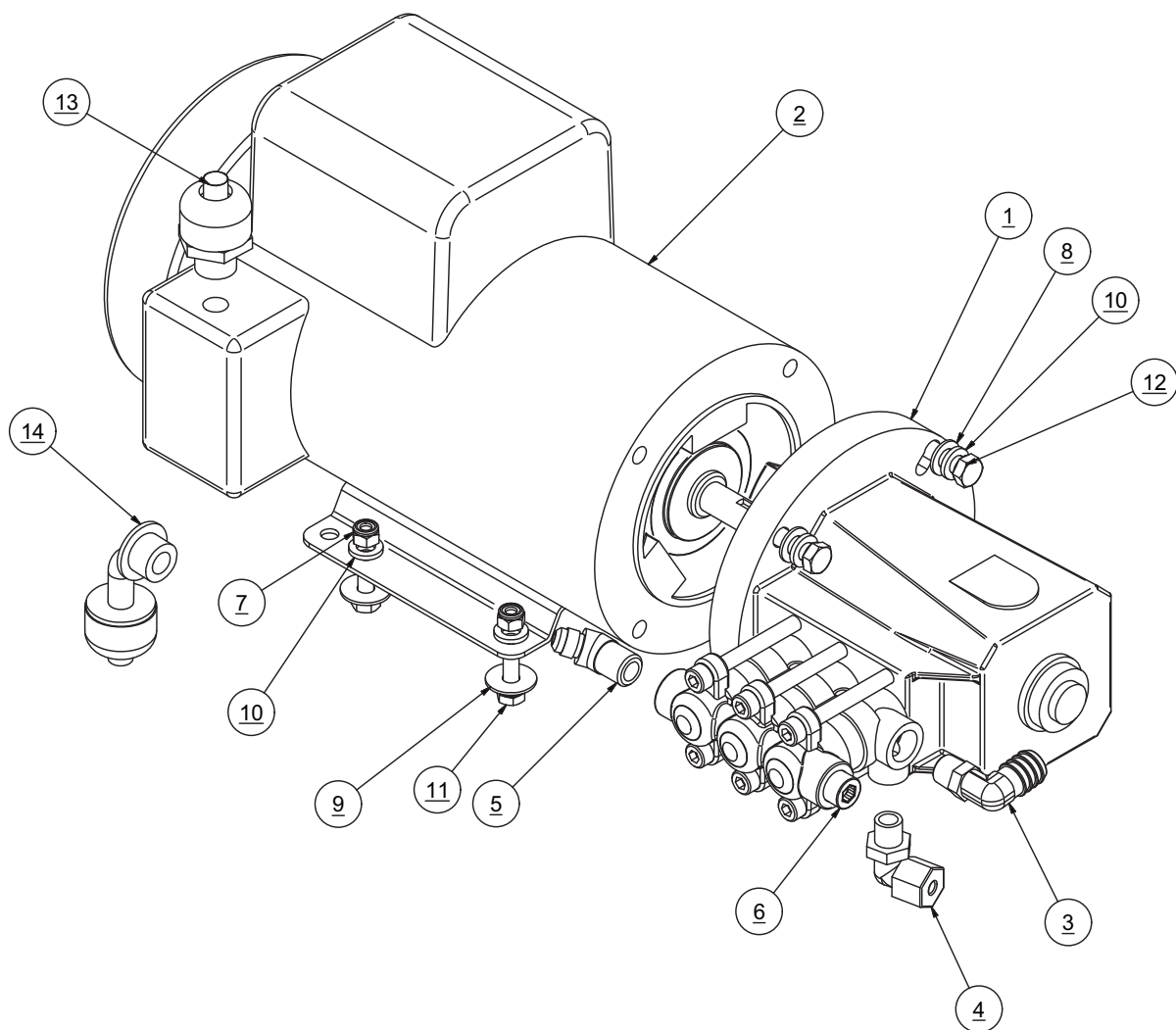
**RECOMMENDED SPARES:**

QTY.	PART NUMBER	DESCRIPTION
1	B653220001	HPP -C SEAL KIT
1	B654220001	HPP -C INLET VALVE REBUILD KIT
1	B652220001	HPP -C PMP KIT SEALS/VALVES

B156230001 HP PUMP-MOTOR 110-220-60HZ AW350

ITEM NO.	QTY.	PART NUMBER	DESCRIPTION
1	1	1218181422	HP PUMP 1.5 GPM SS CAT
2	1	1535231010	MOTOR,1HP,120V,60HK,1 PH
3	1	1317061900	ELB45-6 FLARE X 3-8 MT SS
4	1	0112021800	ELB90 .375 MNPT x .62 BARB NYLON
5	1	0204020869	ELBOW,PP,1/4 ODx1/4 MT
6	2	05181434AA	HOSE CLAMP .75 SS
7	4	061060050000	NUT HEX .31-18 W-INSERT SS
8	1	0117341869	PLUG .375 MNPT SS
9	4	061142150016	SCREW,HEX HEAD,.31-18x1.00,SS
10	4	061120056000	WASHER,LOCK,3/8",SS
11	1	1904010543	STRAIN RELIEF 8400
12	1	1904013543	STRAIN RELIEF 8423
13	4	061080056000	WASHER,FLAT,3/8",SS
14	4	061100049000	WASHER,FLAT,OS,5/16",SS

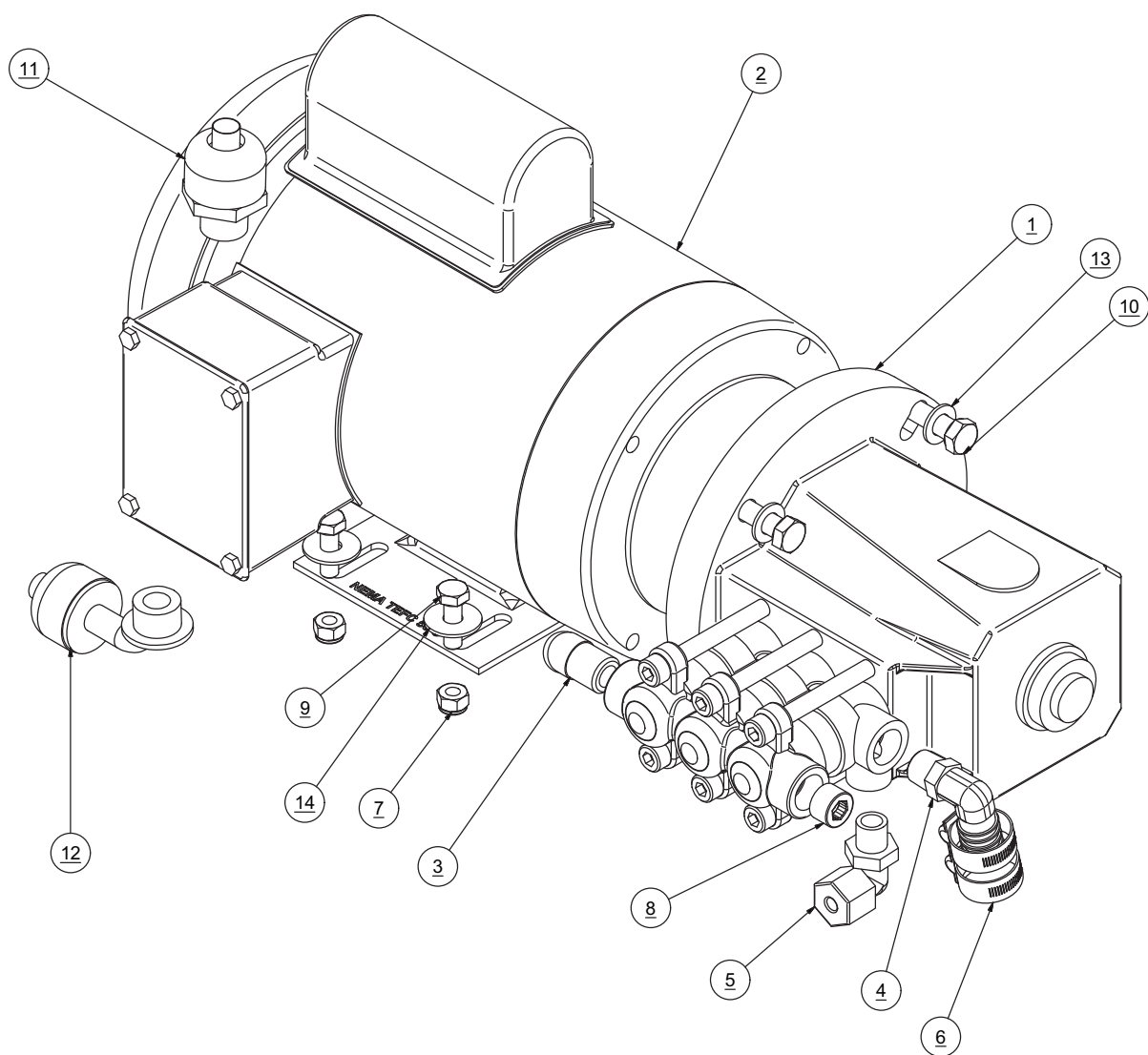
**RECOMMENDED SPARES:**

QTY.	PART NUMBER	DESCRIPTION
1	B653220001	HPP -C SEAL KIT
1	B654220001	HPP -C INLET VALVE REBUILD KIT
1	B652220001	HPP -C PMP KIT SEALS/VALVES

B156230003 HP PUMP-MOTOR 110-220 50-60 1PH

Mini 350, 550, & 750

ITEM NO.	QTY.	PART NUMBER	DESCRIPTION
1	1	12180522CO	HP PUMP GP 2.85 GPM
2	1	15AD062412	MOTOR 2.1 HP 50-60 110-220 1PH
3	1	0112021800	ELB90 .375 MNPT x .62 BARB NYLON
4	1	0204020869	ELBOW,PP,1/4 ODx1/4 MT
5	1	1317061900	ELB45-6 FLARE X 3-8 MT SS
6	1	0117341869	PLUG .375 MNPT SS
7	4	061060050000	NUT HEX .31-18 W-INSERT SS
8	4	061080056000	WASHER,FLAT,3/8",SS
9	4	061100049000	WASHER,FLAT,OS,5/16",SS
10	8	061120056000	WASHER,LOCK,3/8",SS
11	4	061142150016	SCREW,HEX HEAD,.31-18x1.00,SS
12	4	061142157024	SCREW,HEX HEAD,3/8-16x1-1/2",SS
13	1	1904010543	STRAIN RELIEF 8400
14	1	1904013543	STRAIN RELIEF 8423

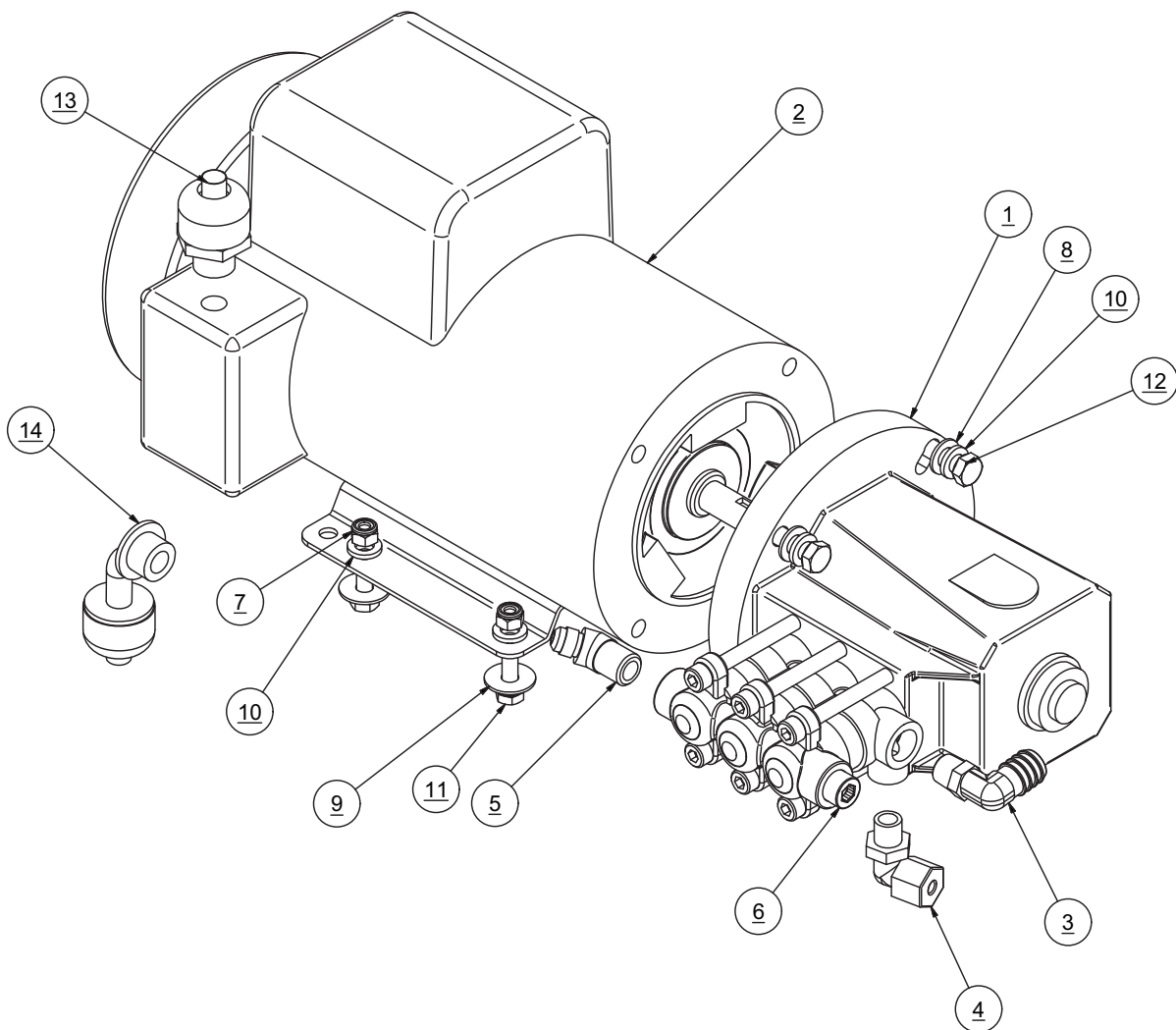
**RECOMMENDED SPARES:**

QTY.	PART NUMBER	DESCRIPTION
1	B653220001	HPP -C SEAL KIT
1	B654220001	HPP -C INLET VALVE REBUILD KIT
1	B652220001	HPP -C PMP KIT SEALS/VALVES

B156230004 HP PUMP-MOTOR 110-220 50-60 AW 550-750 1PH

ITEM NO.	QTY.	PART NUMBER	DESCRIPTION
1	1	15AD062412	MOTOR 2.1 HP 50-60 110-220 1PH
2	1	1218182422	HP PUMP 3.5 GPM SS
3	1	1317061900	ELB45-6 FLARE X 3-8 MT SS
4	1	0112021800	ELB90 .375 MNPT x .62 BARB NYLON
5	1	0204020869	ELBOW,PP,1/4 ODx1/4 MT
6	2	05181434AA	HOSE CLAMP .75 SS
7	4	061060050000	NUT HEX .31-18 W-INSERT SS
8	1	0117341869	PLUG .375 MNPT SS
9	4	061142150016	SCREW,HEX HEAD,.31-18x1.00,SS
10	4	061142157024	SCREW,HEX HEAD,3/8-16x1-1/2",SS
11	1	1904010543	STRAIN RELIEF 8400
12	1	1904013543	STRAIN RELIEF 8423
13	4	061080056000	WASHER,FLAT,3/8",SS
14	4	061100049000	WASHER,FLAT,OS,5/16",SS

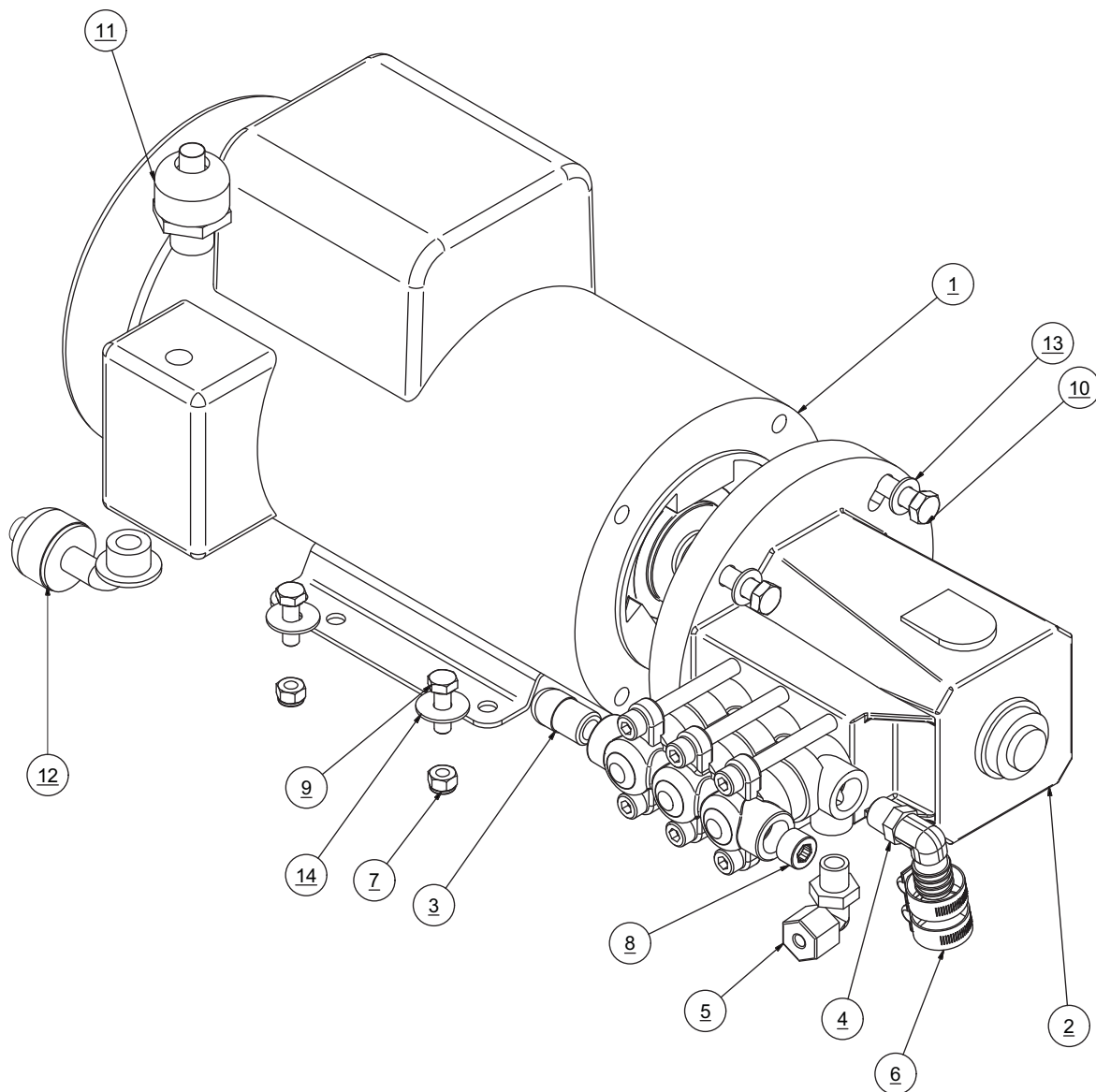
**RECOMMENDED SPARES:**

QTY.	PART NUMBER	DESCRIPTION
1	B653220001	HPP -C SEAL KIT
1	B654220001	HPP -C INLET VALVE REBUILD KIT
1	B652220001	HPP -C PMP KIT SEALS/VALVES

B502220003 MANIFOLD LP ASSY

Mini 170

ITEM NO.	QTY.	PART NUMBER	DESCRIPTION
1	1	2317100200	TRANSDUCER 0-200 PSI .437 SAE
2	1	5333220901	MANIFOLD LP AW 170
3	2	0204090869	FITTING,PP,1/4 ODx1/4 MT
4	2	061161130012	SC PHIL OVAL #10-24 X .75 SS

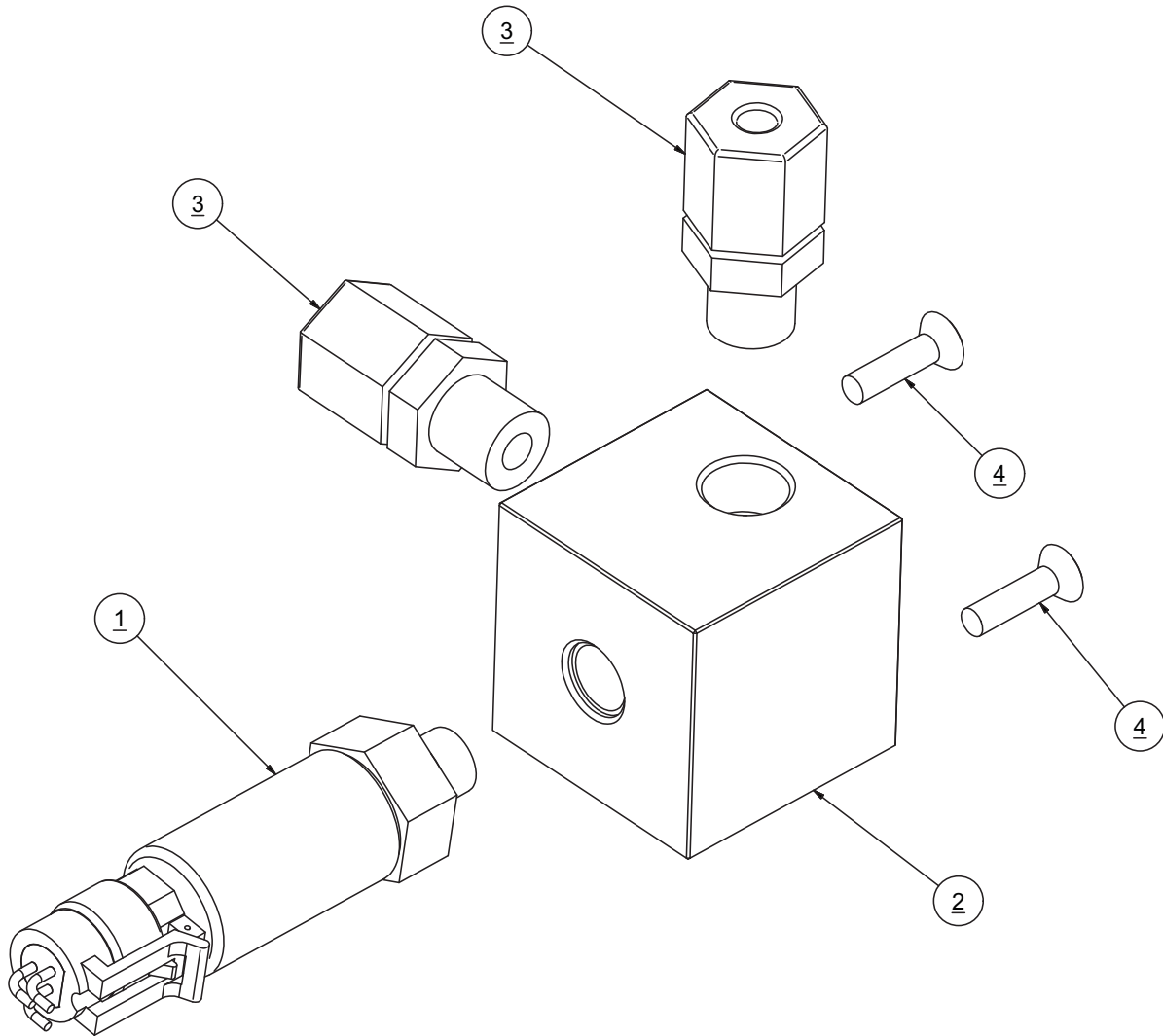

B156230001M HP PUMP-MOTOR 110-220-60HZ AW350-MODULAR

ITEM NO.	QTY.	PART NUMBER	DESCRIPTION
1	1	2020054903A	PANEL MOTOR BASE PLATE
2	1	1218181422	HP PUMP 1.5 GPM SS CAT
3	1	1535231010	MOTOR,1HP,120V,60HK,1 PH
4	4	2115030120	RUBBER MOUNT 55 AQUA SERIES
5	1	1920023632	STRAIN RELIEF 90 CG90-6250
6	1	1317061900	ELB45-6 FLARE X 3-8 MT SS
7	1	0112021800	ELB90 .375 MNPT x .62 BARB NYLON
8	2	0204020869	ELBOW,PP,1/4 ODx1/4 MT
9	4	05181434AA	HOSE CLAMP .75 SS
10	1	063200066000	NUT LOCK .50 STEEL
11	4	061060050000	NUT HEX .31-18 W-INSERT SS
12	1	0117341869	PLUG .375 MNPT SS
13	8	061142150016	SCREW,HEX HEAD,.31-18x1.00,SS
14	4	061142157024	SCREW,HEX HEAD,3/8-16x1-1/2",SS
15	4	061080056000	WASHER,FLAT,3/8",SS
16	12	061100049000	WASHER,FLAT,OS,5/16",SS

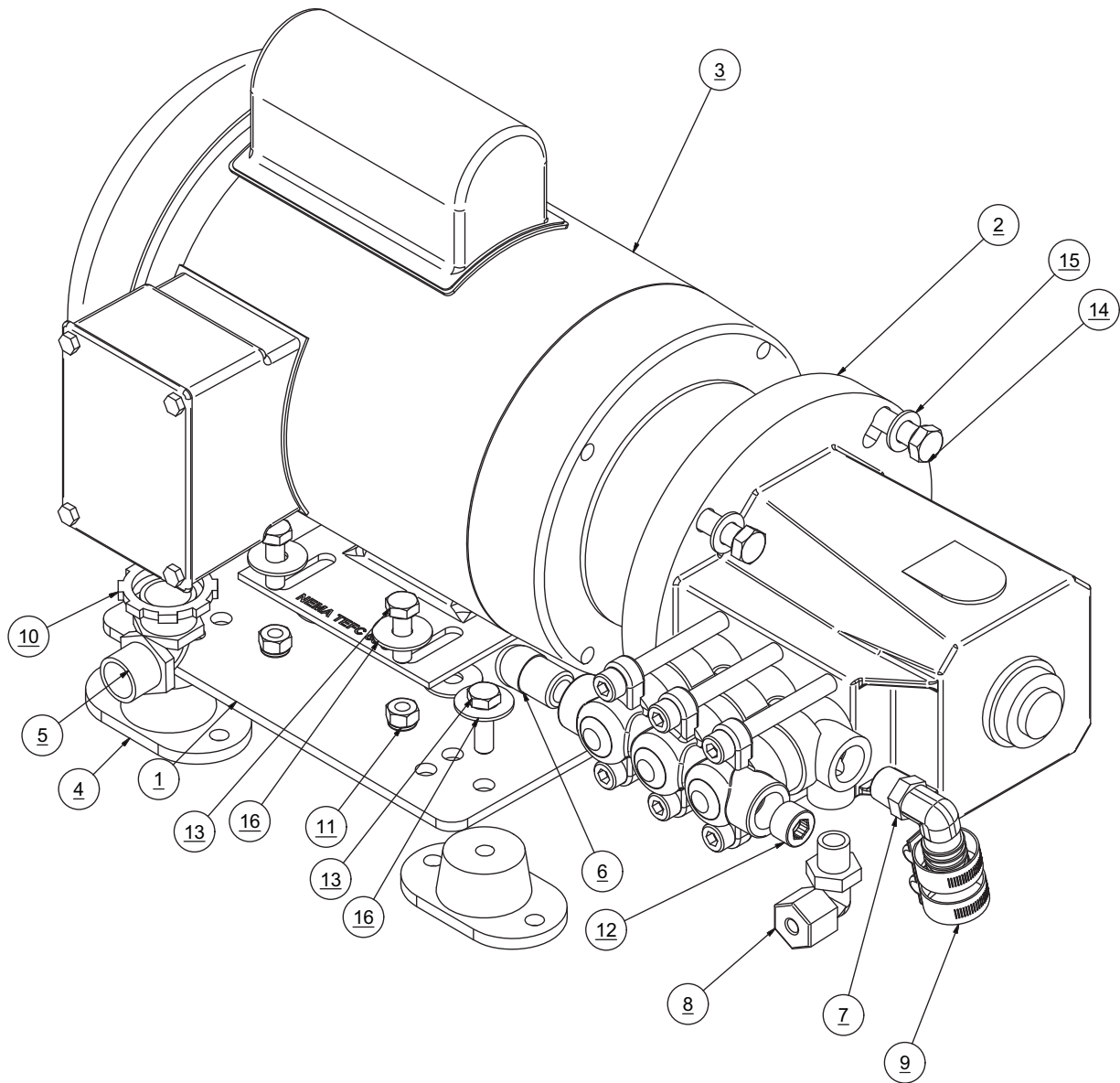

RECOMMENDED SPARES:

QTY.	PART NUMBER	DESCRIPTION
1	B653220001	HPP -C SEAL KIT
1	B654220001	HPP -C INLET VALVE REBUILD KIT
1	B652220001	HPP -C PMP KIT SEALS/VALVES

B156230002M HP PUMP-MOTOR 110-220 50HZ AW 350-MODULAR

ITEM NO.	QTY.	PART NUMBER	DESCRIPTION
1	1	2020054903A	PANEL MOTOR BASE PLATE
2	1	1218181422	HP PUMP 1.5 GPM SS CAT
3	1	1534231010	MOTOR 1 HP 115-220-50-1 PH
4	4	2115030120	RUBBER MOUNT 55 AQUA SERIES
5	1	1920023632	STRAIN RELIEF 90 CG90-6250
6	1	1317061900	ELB45-6 FLARE X 3-8 MT SS
7	1	0112021800	ELB90 .375 MNPT x .62 BARB NYLON
8	2	0204020869	ELBOW,PP,1/4 ODx1/4 MT
9	4	05181434AA	HOSE CLAMP .75 SS
10	1	063200066000	NUT LOCK .50 STEEL
11	4	061060050000	NUT HEX .31-18 W-INSERT SS
12	1	0117341869	PLUG .375 MNPT SS
13	8	061142150016	SCREW,HEX HEAD,.31-18x1.00,SS
14	4	061142157024	SCREW,HEX HEAD,3/8-16x1-1/2",SS
15	4	061080056000	WASHER,FLAT,3/8",SS
16	12	061100049000	WASHER,FLAT,OS,5/16",SS

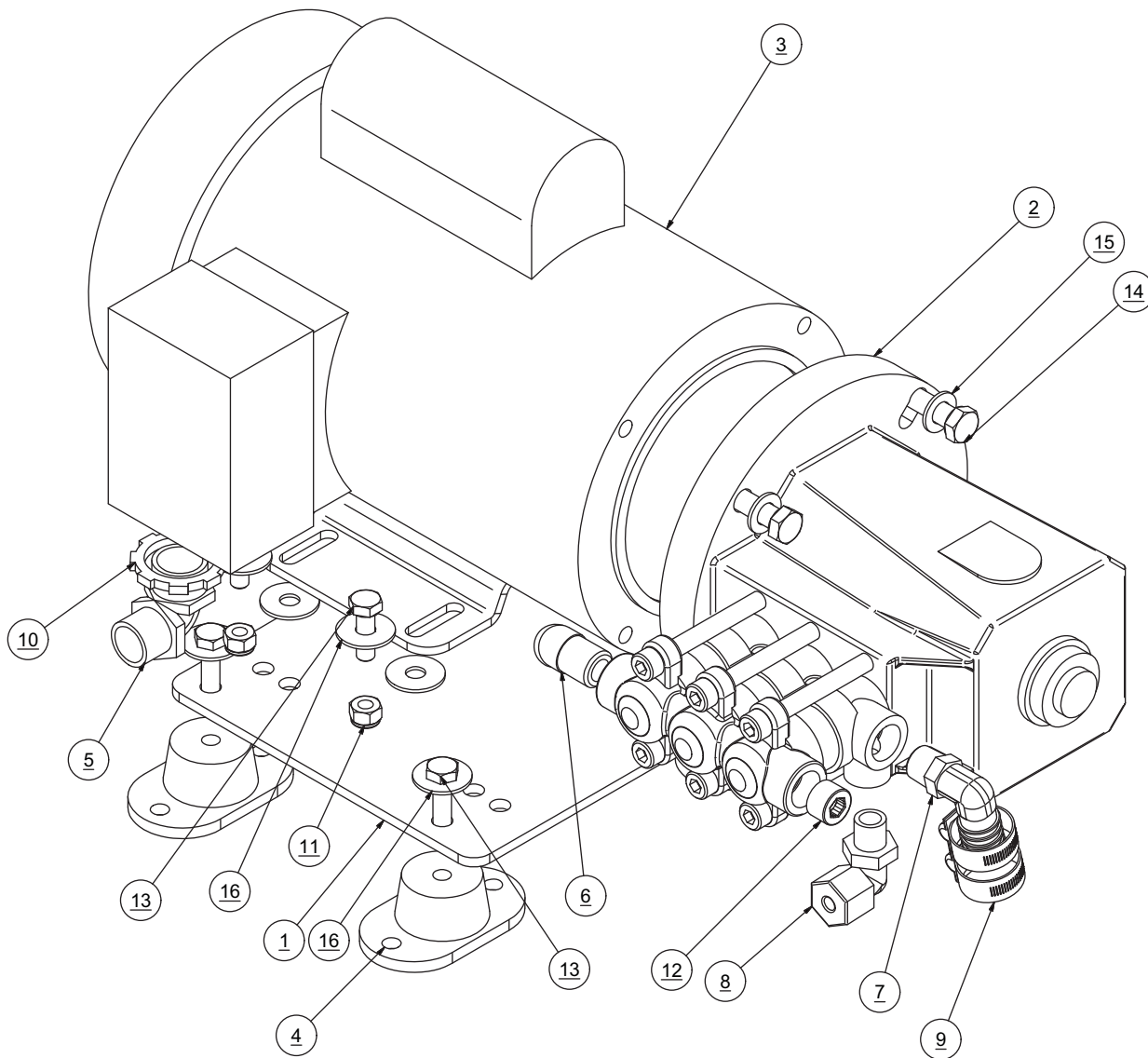

RECOMMENDED SPARES:

QTY.	PART NUMBER	DESCRIPTION
1	B653220001	HPP -C SEAL KIT
1	B654220001	HPP -C INLET VALVE REBUILD KIT
1	B652220001	HPP -C PMP KIT SEALS/VALVES

B156230004M HP PUMP-MOTOR 110-220 50-60 AW 550-750 1PH-MODULAR

ITEM NO.	QTY.	PART NUMBER	DESCRIPTION
1	1	2020054903A	PANEL MOTOR BASE PLATE
2	1	15AD062412	MOTOR 2.1 HP 50-60 110-220 1PH
3	4	2115030120	RUBBER MOUNT 55 AQUA SERIES
4	1	1218182422	HP PUMP 3.5 GPM SS
5	1	1920023632	STRAIN RELIEF 90 CG90-6250
6	1	1317061900	ELB45-6 FLARE X 3-8 MT SS
7	1	0112021800	ELB90 .375 MNPT x .62 BARB NYLON
8	2	0204020869	ELBOW,PP,1/4 ODx1/4 MT
9	4	05181434AA	HOSE CLAMP .75 SS
10	1	063200066000	NUT LOCK .50 STEEL
11	4	061060050000	NUT HEX .31-18 W-INSERT SS
12	1	0117341869	PLUG .375 MNPT SS
13	8	061142150016	SCREW,HEX HEAD,.31-18x1.00,SS
14	4	061142157024	SCREW,HEX HEAD,3/8-16x1-1/2",SS
15	4	061080056000	WASHER,FLAT,3/8",SS
16	12	061100049000	WASHER,FLAT,OS,5/16",SS

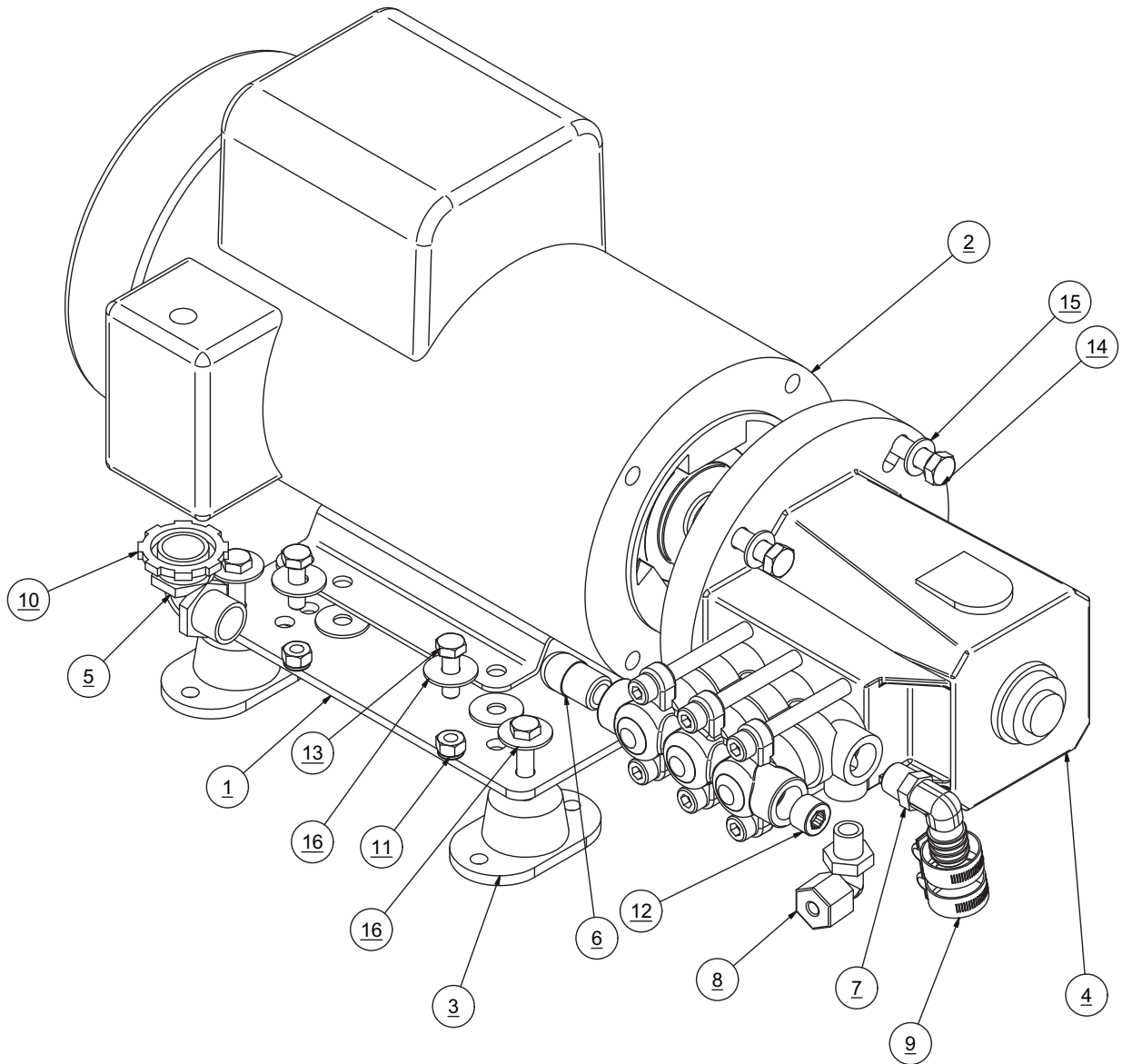

RECOMMENDED SPARES:

QTY.	PART NUMBER	DESCRIPTION
1	B653220001	HPP -C SEAL KIT
1	B654220001	HPP -C INLET VALVE REBUILD KIT
1	B652220001	HPP -C PMP KIT SEALS/VALVES

B502220003M MANIFOLD LP ASSY

Mini 350, 550, 750

ITEM NO.	QTY.	PART NUMBER	DESCRIPTION
1	1	2317100200	TRANSDUCER 0-200 PSI .437 SAE
2	1	5333220901	MANIFOLD LP AW 170
3	2	0204020869	ELBOW,PP,1/4 ODx1/4 MT
4	2	061161130012	SC PHIL OVAL #10-24 X .75 SS

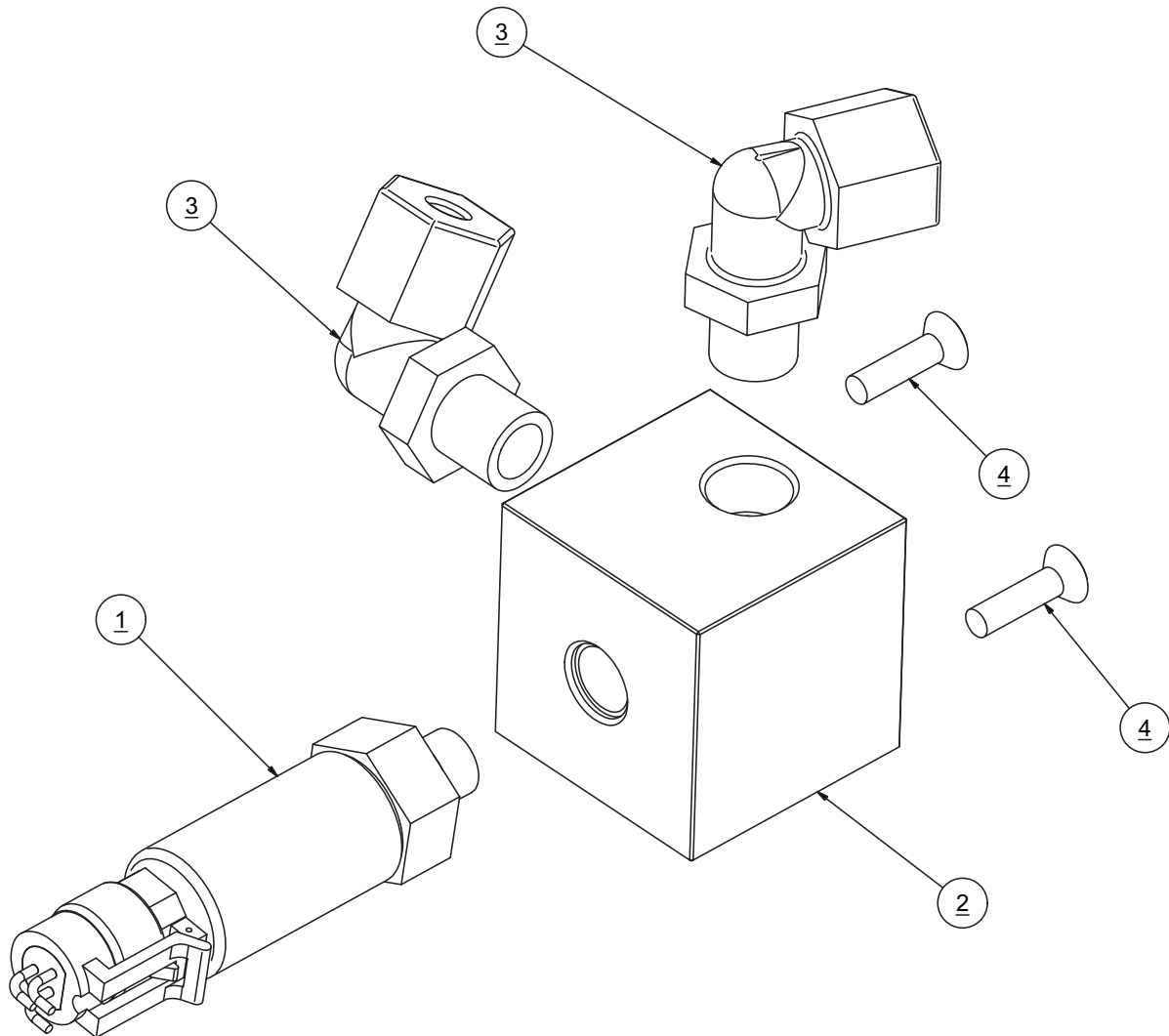

B502230004 CONTROL MANIFOLD ASSY

Mini 170

ITEM NO.	QTY.	PART NUMBER	DESCRIPTION
1	1	5333220701	MANIFOLD CONTROL AW 170 (2012)
2	1	0520210500	RETAINER PORT MVA AW 170
3	1	0204120869	FITTING, PP, 1/2"OD X 1/2FT
4	1	10181522CC	GAUGE -30-0-70 CBM.NPT
5	1	1401096100	VALVE SOLENOID 12VDC
6	1	05180851CC	BRACKET,GAUGE,CBM,SS
7	1	1105400153	FLOW METER 0-12 GPH AW170
8	1	10181421CC	GAUGE 0-1400 CBM.O-RING SEAL
9	1	H32458020158	KNOB BP REGULATOR
10	1	B511080003	SALINITY PROBE ASSY
11	1	2317100200	TRANSDUCER 0-200 PSI .437 SAE
12	1	1417021000	VALVE STEM PRESS REG AW 170
13	1	1317010869	ELB90 -4 FLARE X .25 FPT SS
14	1	0204021769	ELB90 .375 TUBE x .25 MNPT PLASTIC
15	1	0204020869	ELBOW,PP,1/4 ODx1/4 MT
16	1	0204090869	FITTING,PP,1/4 ODx1/4 MT
17	1	0117410801	HP NIPPLE, MVA, AW 170
18	3	0117340800	PLUG SOC ,0.25 MT SS
19	2	2614014600	O-RING 113 PLUG PRODUCT AW-FM
20	1	061170618109	SC PHIL PAN A #6 X .75 SS
21	2	H30612730006	INSERT 8-32 X .31-18 SS
22	2	2614015800	O-RING 011 GAUGE-PRES SWITCH
23	4	2614017100	O-RING 111 SALINITY PRB-BPR CS
24	2	061160526048	SC 8-32 x 3.00 SS
25	2	061162020008	SC PHIL FLAT #6-32 x .50SS

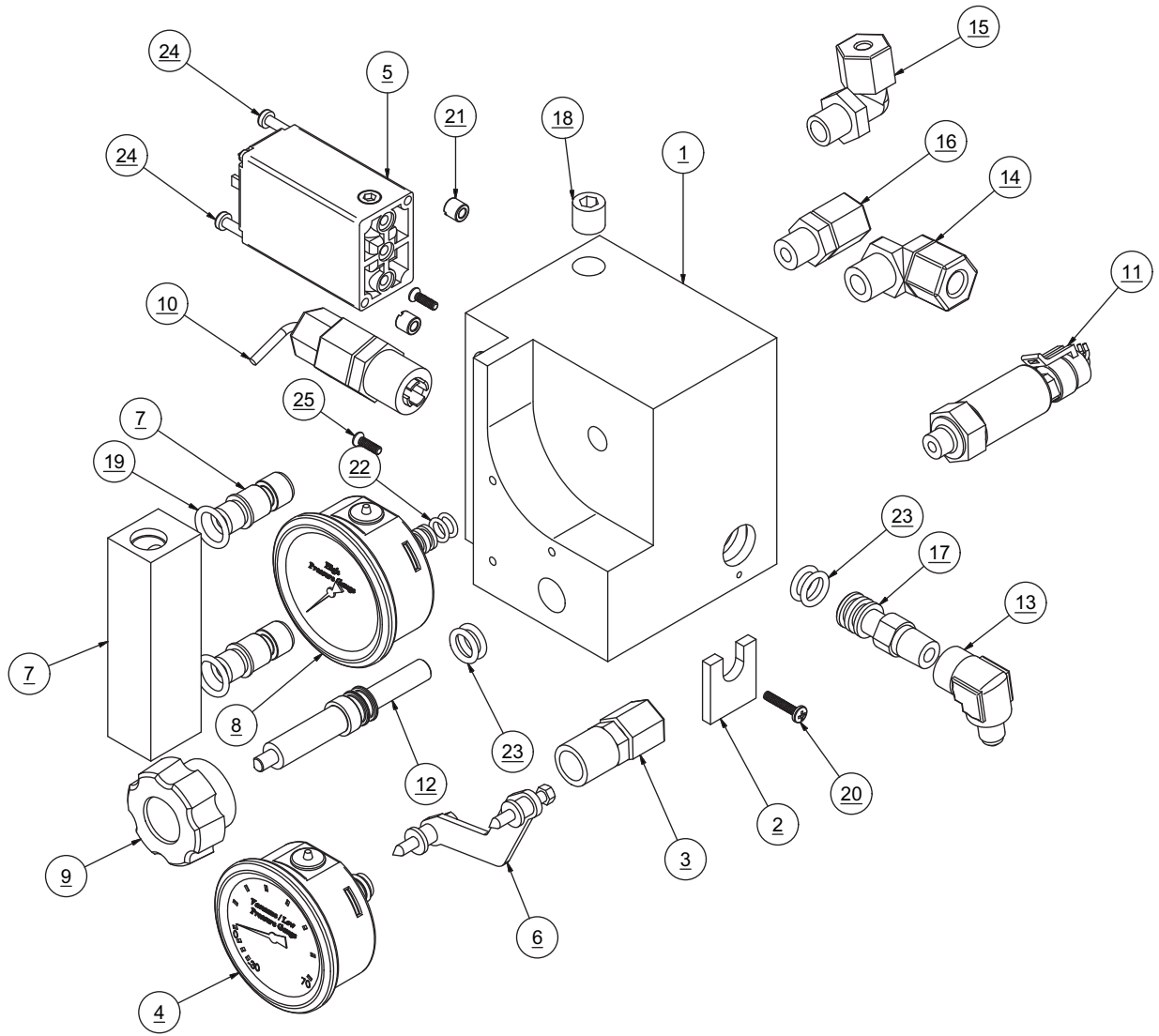

B502230003 CONTROL MANIFOLD ASSY

Mini 350, 550, 750

ITEM NO.	QTY.	PART NUMBER	DESCRIPTION
1	1	5333220701	MANIFOLD CONTROL AW 170 (2012)
2	1	0520210500	RETAINER PORT MVA AW 170
3	1	0204120869	FITTING, PP, 1/2"OD X 1/2FT
4	1	10181522CC	GAUGE -30-0-70 CBM.NPT
5	1	1401096100	VALVE SOLENOID 12VDC
6	1	05180851CC	BRACKET,GAUGE,CBM,SS
7	1	1105400153	FLOW METER 0-12 GPH AW170
8	1	10181421CC	GAUGE 0-1400 CBM.O-RING SEAL
9	1	H32458020158	KNOB BP REGULATOR
10	1	B511080003	SALINITY PROBE ASSY
11	1	2317100200	TRANSDUCER 0-200 PSI .437 SAE
12	1	1417021000	VALVE STEM PRESS REG AW 170
13	1	1317010869	ELB90 -4 FLARE X .25 FPT SS
14	1	0204021769	ELB90 .375 TUBE x .25 MNPT PLASTIC
15	1	0204022369	ELBOW,PP,1/2 ODx1/4 MT
16	1	0204090869	FITTING,PP,1/4 ODx1/4 MT
17	1	0117410801	HP NIPPLE, MVA, AW 170
18	3	0117340800	PLUG SOC ,0.25 MT SS
19	2	2614014600	O-RING 113 PLUG PRODUCT AW-FM
20	1	061170618109	SC PHIL PAN A #6 X .75 SS
21	2	H30612730006	INSERT 8-32 X .31-18 SS
22	2	2614015800	O-RING 011 GAUGE-PRES SWITCH
23	4	2614017100	O-RING 111 SALINITY PRB-BPR CS
24	2	061160526048	SC 8-32 x 3.00 SS
25	2	061162020008	SC PHIL FLAT #6-32 x .50SS

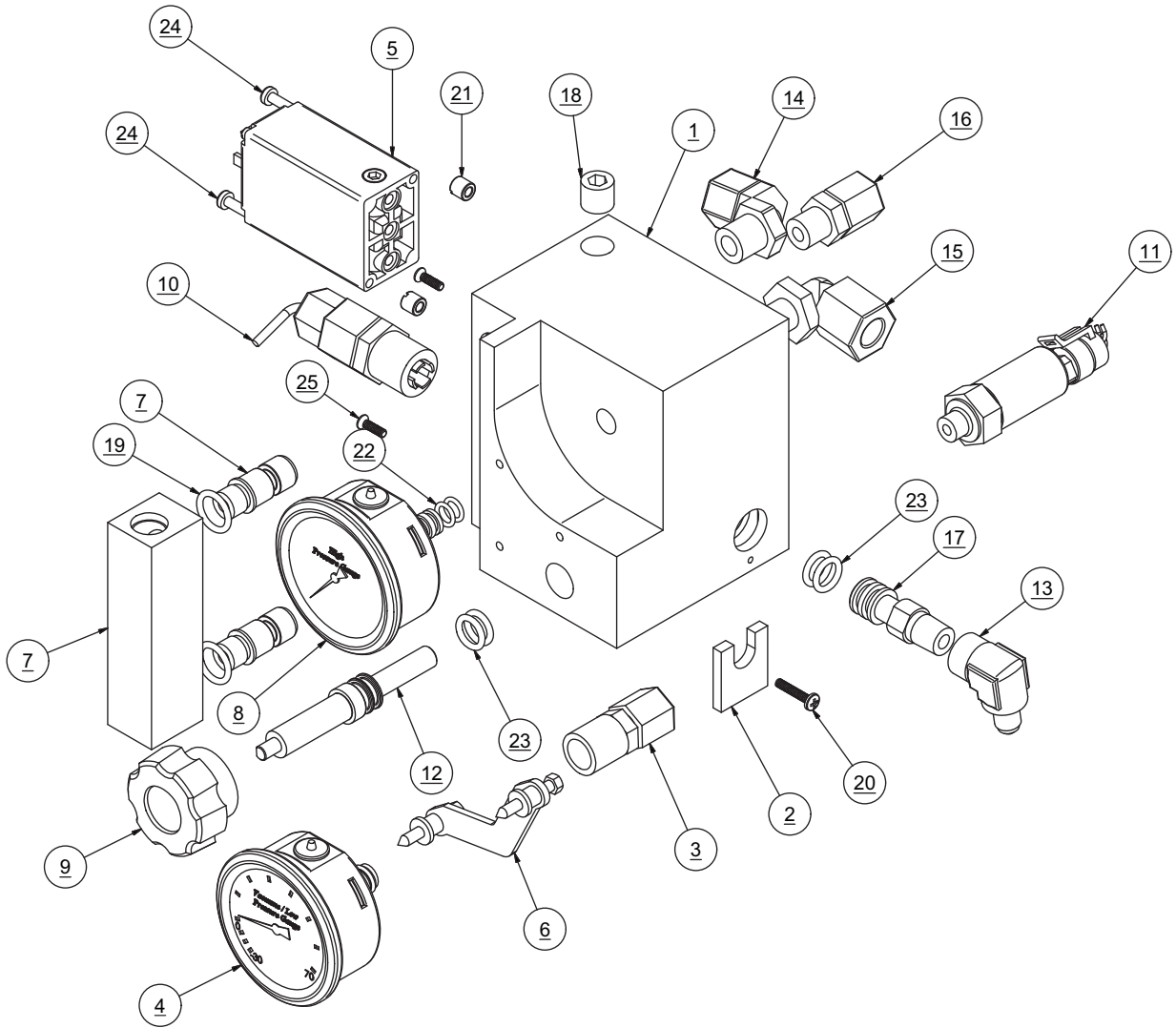

B502230003M CONTROL MANIFOLD ASSY MODULAR

Modular

ITEM NO.	QTY.	PART NUMBER	DESCRIPTION
1	1	5333220701	MANIFOLD CONTROL AW 170 (2012)
2	1	0520210500	RETAINER PORT MVA AW 170
3	1	0204120869	FITTING, PP, 1/2"OD X 1/2FT
4	1	10181522CC	GAUGE -30-0-70 CBM.NPT
5	1	1401096100	VALVE SOLENOID 12VDC
6	1	05180851CC	BRACKET,GAUGE,CBM,SS
7	1	1105400153	FLOW METER 0-12 GPH AW170
8	1	10181421CC	GAUGE 0-1400 CBM.O-RING SEAL
9	1	H32458020158	KNOB BP REGULATOR
10	1	B511080003	SALINITY PROBE ASSY
11	1	2317100200	TRANSDUCER 0-200 PSI .437 SAE
12	1	1417021000	VALVE STEM PRESS REG AW 170
13	1	1317010869	ELB90 -4 FLARE X .25 FPT SS
14	1	0204021769	ELB90 .375 TUBE x .25 MNPT PLASTIC
15	1	0204022369	ELBOW,PP,1/2 ODx1/4 MT
16	1	0204090869	FITTING,PP,1/4 ODx1/4 MT
17	1	0117410801	HP NIPPLE, MVA, AW 170
18	3	0117340800	PLUG SOC ,0.25 MT SS
19	2	2614014600	O-RING 113 PLUG PRODUCT AW-FM
20	1	061170618109	SC PHIL PAN A #6 X .75 SS
21	1	01172308BN	ELB90 ST 1/4 MPT X1/4 FPT 316SS -W/ORING
22	2	H30612730006	INSERT 8-32 X .31-18 SS
23	2	2614015800	O-RING 011 GAUGE-PRES SWITCH
24	4	2614017100	O-RING 111 SALINITY PRB-BPR CS
25	2	061160526048	SC 8-32 x 3.00 SS
26	2	061162020008	SC PHIL FLAT #6-32 x .50SS

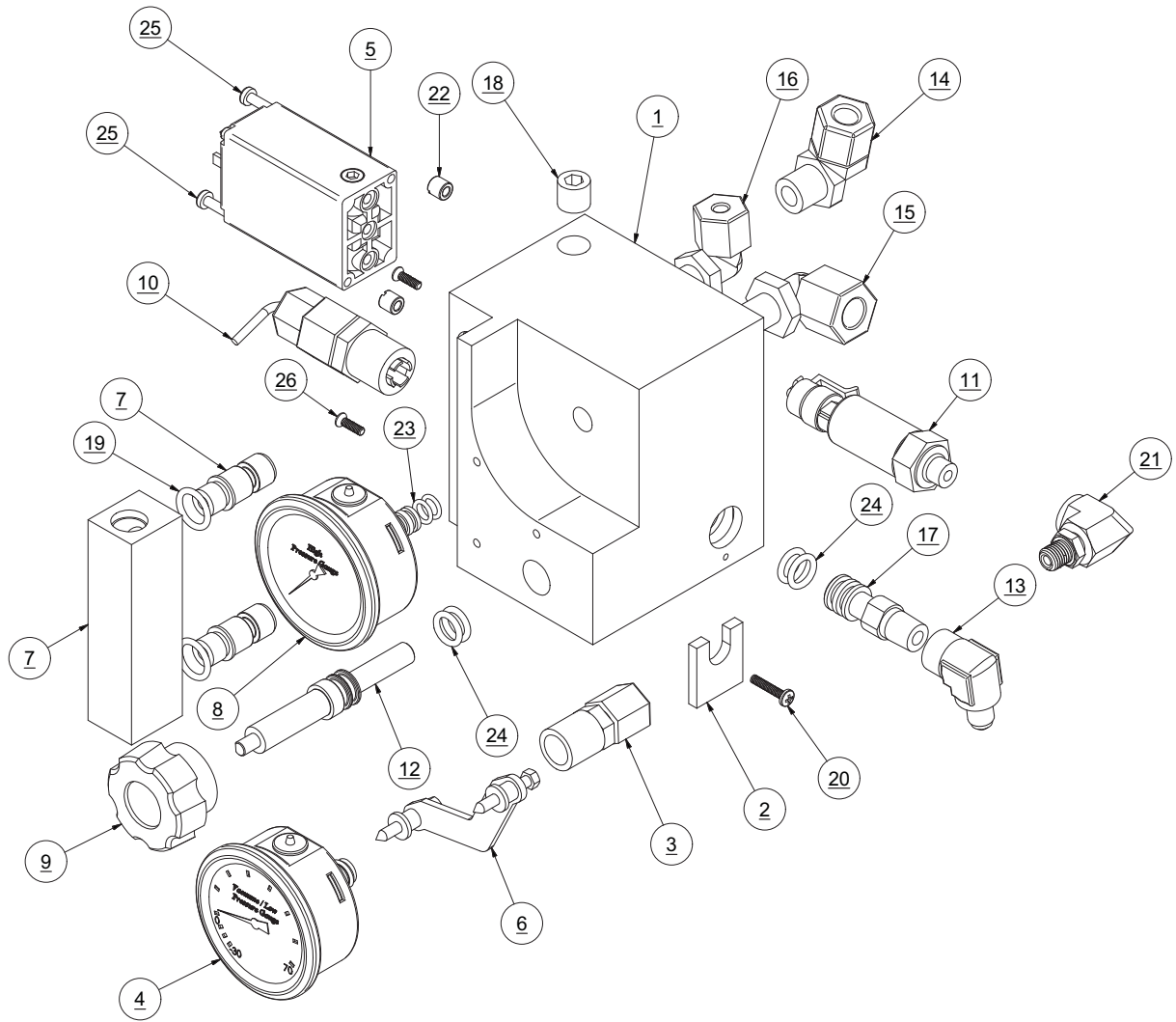

1401096100 3-WAY PRODUCT WATER DIVERSION SOLENOID VALVE

PORT DESIGNATION & DESCRIPTION (WATER FLOW)

VALVE WITH PORT DESIGNATION "A" "P" "B"

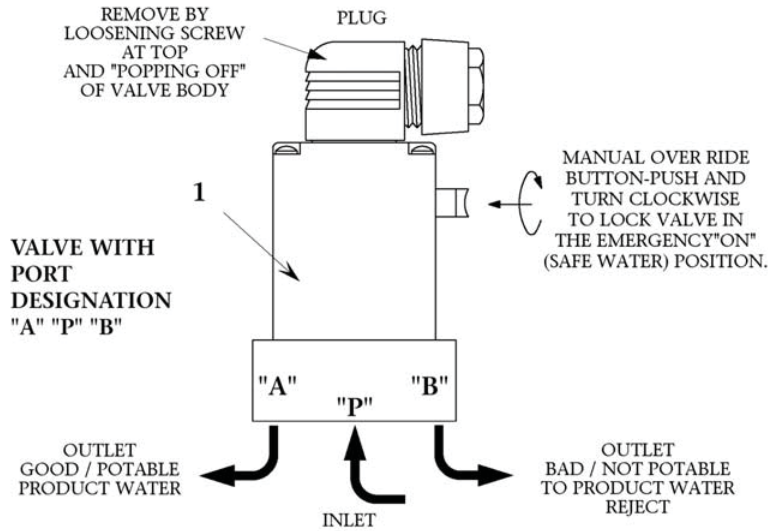

PLUMBING CONNECTIONS
 "A" = NORMALLY CLOSED -TO CHARCOAL FILTER INLET (GOOD WATER)
 "P" = INLET (COMMON)
 "B" = NORMALLY OPEN -TO DISCHARGE (BAD WATER)

VALVE WITH PORT DESIGNATION "R" "B" "P"

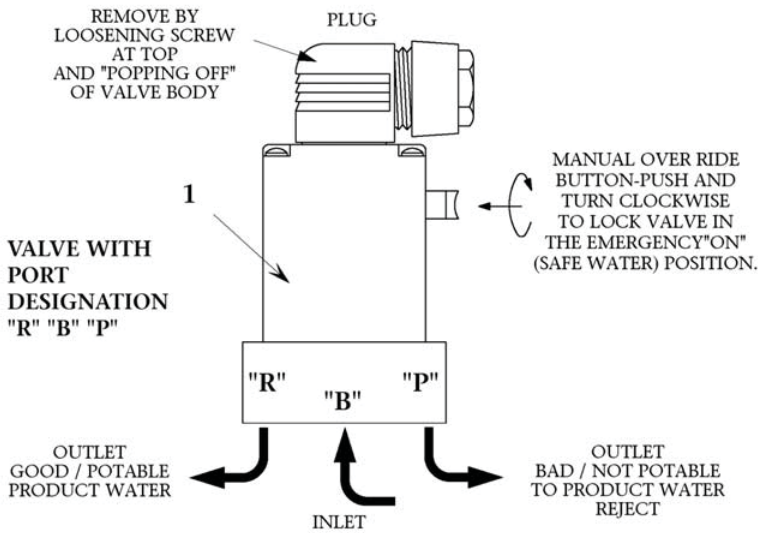

PLUMBING CONNECTIONS
 "R" = NORMALLY CLOSED -TO CHARCOAL FILTER INLET (GOOD WATER)
 "B" = INLET (COMMON)
 "P" = NORMALLY OPEN -TO DISCHARGE (BAD WATER)

B107220002 PREFILTER ASSY 170

ITEM NO.	QTY.	PART NUMBER	DESCRIPTION
1	1	20200402102	BRACKET SINGLE FILTER
2	1	0713020573	FILTER HOUSING-LID .375 X 10 ASM
3	1	0801060157	ELEMENT PREFILTER 10-05
4	2	0112072500	ELB90 0.50 MPT x 0.50 BARB
5	4	061172143016	SCREX,HEX A,.25x1.00,SS
6	4	05181432AA	CLAMP,HOSE,SS,1/2"
7	4	061170628016	SC PHIL PAN A #10 X 1 SS
8	4	065080028000	WASHER FLAT #10 NYLON
9	4	061100043000	WASHER,FLAT,OS,1/4",SS

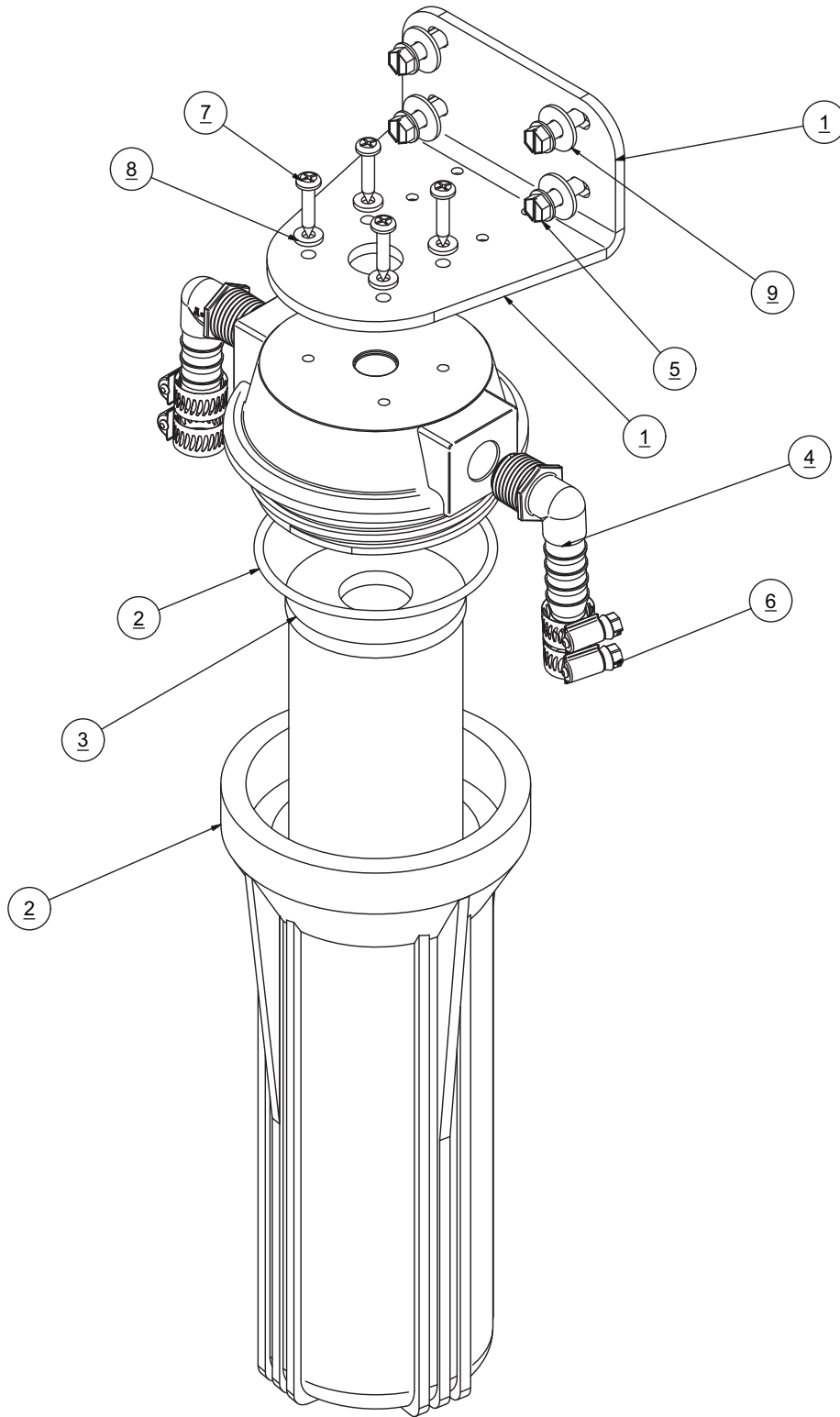

RECOMMENDED SPARES:

QTY.	PART NUMBER	DESCRIPTION
1	2614010473	ORING BLUE HSG 237

B107230001 PREFILTER ASSY DUAL 350

ITEM NO.	QTY.	PART NUMBER	DESCRIPTION
1	1	20200402101	DUAL BRACKET PREFILTER-CHRCL-PLNKTN Rev A
2	2	0713020873-1	FILTER HOUSING .50 X 10 LID
3	2	0713020873-2	FILTER HOUSING .50 X 10 BODY
4	2	0713020873-3	FILTER HOUSING .50 X 10 O-RING
5	1	0801060157	ELEMENT PREFILTER 10-05
6	1	0801130257	ELEMENT PREFILTER 10-25
7	1	01013725CL	NIPPLE 0.50 NPT x CL
8	2	0112072500	ELB90 0.50 MPT x 0.50 BARB
9	4	05181434AA	HOSE CLAMP .75 SS
10	4	061060045000	NUT HEX .25-20 W-INSERT SS
11	8	061080028000	WASHER FLAT #10 SS
12	4	061100043000	WASHER FLAT OS .25 SS
13	4	061142145012	BOLT HEX .25-20 X .75 SS
14	8	061170628016	SC PHIL PAN A #10 X 1 SS
15	1	2234012360	LABEL 25 MICRON PREFILTER -1
16	1	2234012460	LABEL 5 MICRON PREFILTER -2

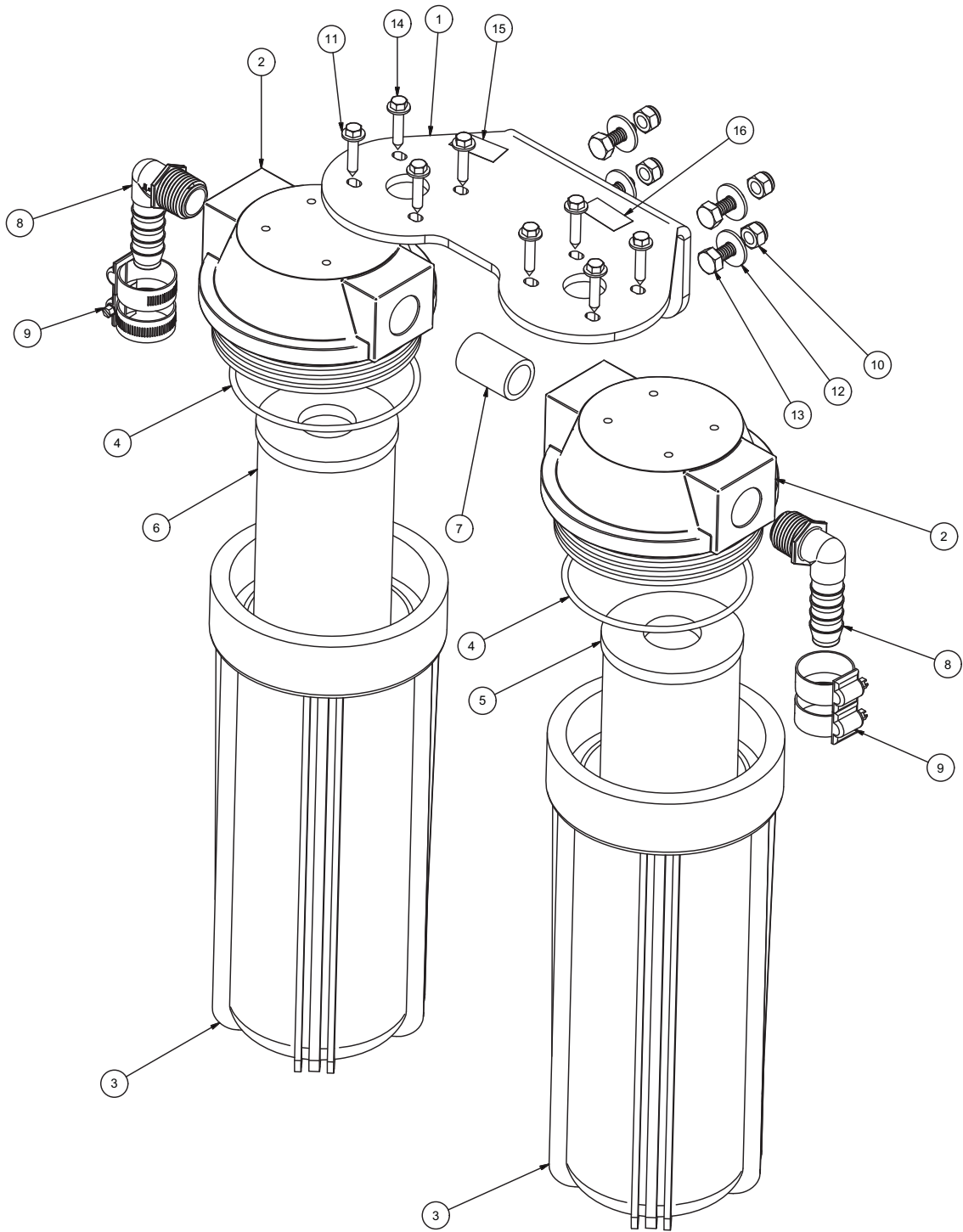

RECOMMENDED SPARES:

QTY.	PART NUMBER	DESCRIPTION
1	2614010473	ORING BLUE HSG 237

B598000009 FRESH WATER FLUSH 10" HOUSING

ITEM NO.	QTY.	PART NUMBER	DESCRIPTION
1	1	20200402102	BRACKET SINGLE FILTER
2	1	0713020573	FILTER HOUSING-LID .375 X 10 ASM
3	1	0801060157	ELEMENT PREFILTER 10-05
4	1	0112072500	ELB90 0.50 MPT x 0.50 BARB
5	1	061172143016	SCREX,HEX A,.25x1.00,SS
6	1	05181432AA	CLAMP,HOSE,SS,1/2"
7	1	061170628016	SC PHIL PAN A #10 X 1 SS
8	1	065080028000	WASHER FLAT #10 NYLON
9	2	061100043000	WASHER,FLAT,OS,1/4",SS
10	1	0204092069	CONN .375 TUBE X .75 MPT PLASTIC
11	1	0204091769	CONN .375 TUBE x .250 MT PLASTIC
12	1	0204021969	ELBOW,PP,3/8 ODx1/2 MT
13	1	0204011769	ELBOW,PP,3/8 ODx1/4 FT
14	1	01123737DG	NIP 0.75 NPT X 0.75 NPT NYLON
15	1	0101340883	PLUG 0.25 MT
16	8	061172143016	SCREX,HEX A,.25x1.00,SS
17	1	01124237DG	TEE 0.75 FPT X FPT X FPT NYLON
18	1	14172105AT	VALVE CHECK .25 MPT SS
19	4	05181434AA	HOSE CLAMP .75 SS
20	1	0501164500	PIPE SUPPORT 1.25
21	4	061170623008	SC PHIL PAN B #8 X .50 SS
22	2	061060026000	NUT,HEX,8-32 W-INSERT SS
23	1	0501164200	PIPE SUPPORT 1.125
24	2	061161626012	SC PHIL FLAT #8-32 X .75 SS
25	4	061170628016	SC PHIL PAN A #10 X 1 SS
26	4	065080028000	WASHER FLAT #10 NYLON
27	8	061100043000	WASHER,FLAT,OS,1/4",SS

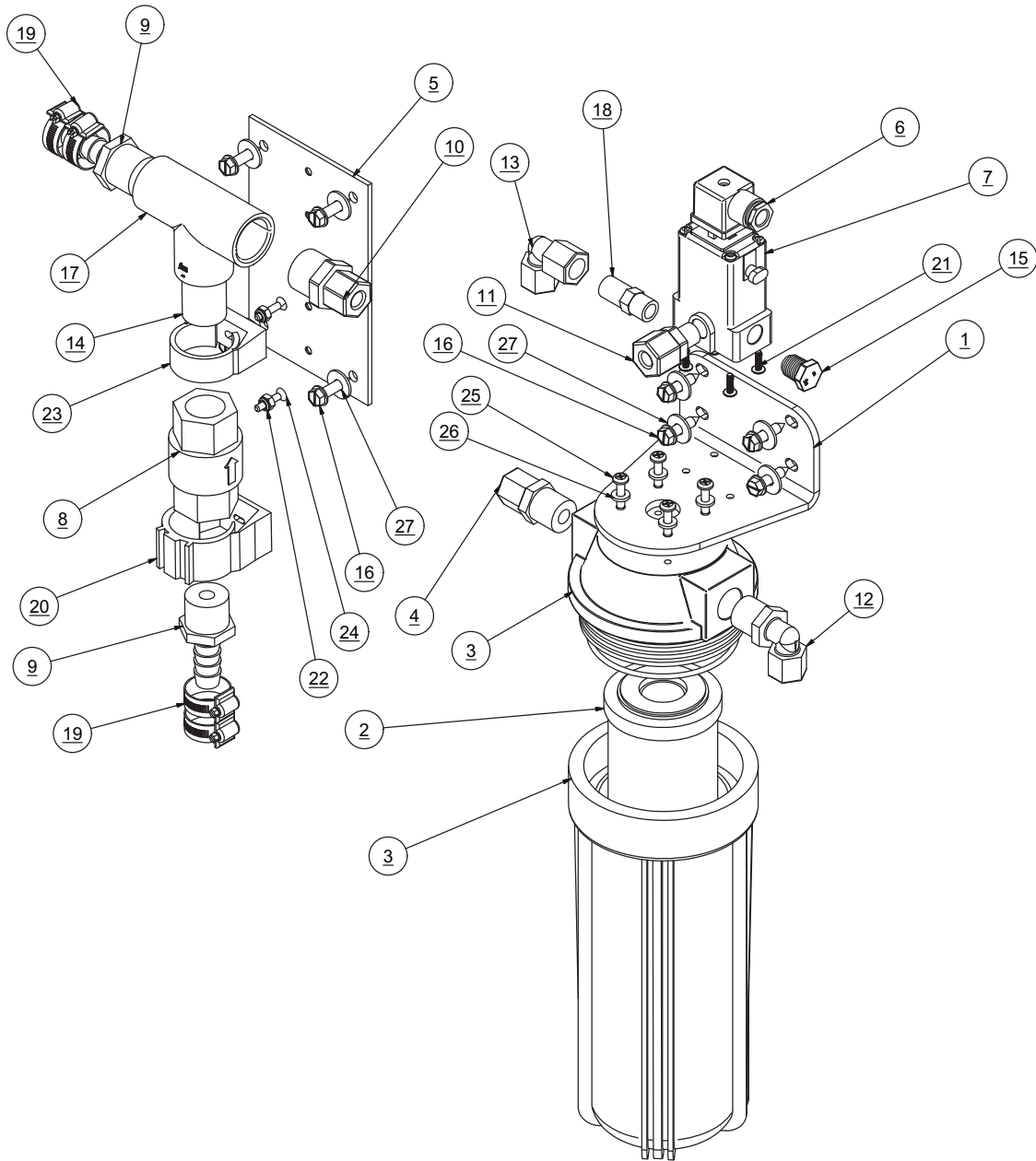

RECOMMENDED SPARES:

QTY.	PART NUMBER	DESCRIPTION
1	2614010473	ORING BLUE HSG 237

B521220002 CHARCOAL FILTER ASSY 170-350

ITEM NO.	QTY.	PART NUMBER	DESCRIPTION
1	1	20200402102	BRACKET SINGLE FILTER
2	1	0713020573	FILTER HOUSING-LID .375 X 10 ASM
3	1	0803004773	ELEMENT CHARCOAL 10.0
4	1	01100719FX	ELB9 0.375MPT X 0.50 BARBTEFBLU
5	2	0204020969	ELB90 .25 TUBE x .375 MPT PLASTIC
6	2	0204021869	ELBOW,SS,3/8 ODx3/8 MT
7	4	061170628016	SC PHIL PAN A #10 X 1 SS
8	4	061170628020	SC PHIL PAN A #10 X 1.25 SS
9	8	065080028000	WASHER FLAT #10 NYLON
10	1	2234018100	LABEL, CHARCOAL(BLUE ON WHITE)

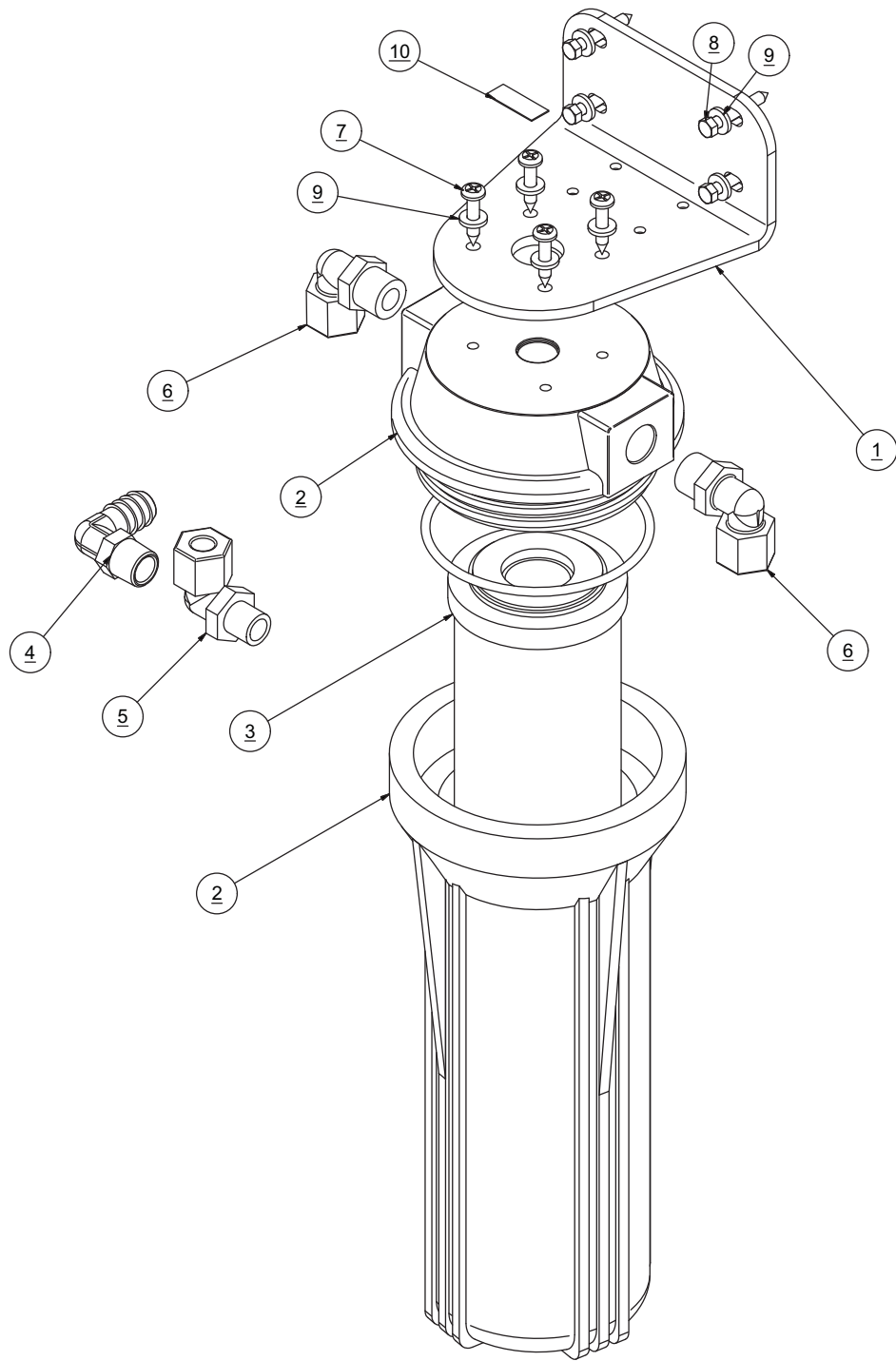

RECOMMENDED SPARES:

QTY.	PART NUMBER	DESCRIPTION
1	2614010473	ORING BLUE HSG 237

B107230005 COMMERCIAL PREFILTER ASSY

ITEM NO.	QTY.	PART NUMBER	DESCRIPTION
1	1	07620310WA	FILTER HOUSING 32.5 SQFT
2	1	0801063357	ELEMENT CPFE 5 MIC 32.5 SQFT
3	1	10180103CC	GAUGE -30-0-70 BPM.NPT
4	1	1404553800	VALVE AIR BLEED .25 TUBE X .25 TUBE
5	2	0112653706	ADAP .75 MPT X .63 BARB NYLON
6	4	061172143016	SCREX,HEX A,.25x1.00,SS
7	1	0204090300	ADAPTER .375 X .25 BSP JG QUIK
8	1	0204092070	CONN .375 TUBE X .25 FNPT
9	1	0204090400	ADAPTER 0.25 X 0.25 BSP JG QUIK
10	2	3901040100	ADAPTER SPACER RING, COMMERCIAL FILTERS
11	4	05181434AA	CLAMP,HOSE,SS,3/4"
12	2	2614018969	O-RONG 034 COMMERCIAL PREFILTER SEAL
13	4	061080028000	WASHER FLAT #10 SS
14	1	2213017063	LABEL INLET (WHITE BACKGROUND)
15	1	2213017163	LABEL OUTLET (WHITE BACKGROUND)
16	1	2234010400	LABEL SRC COMM PREFILTER

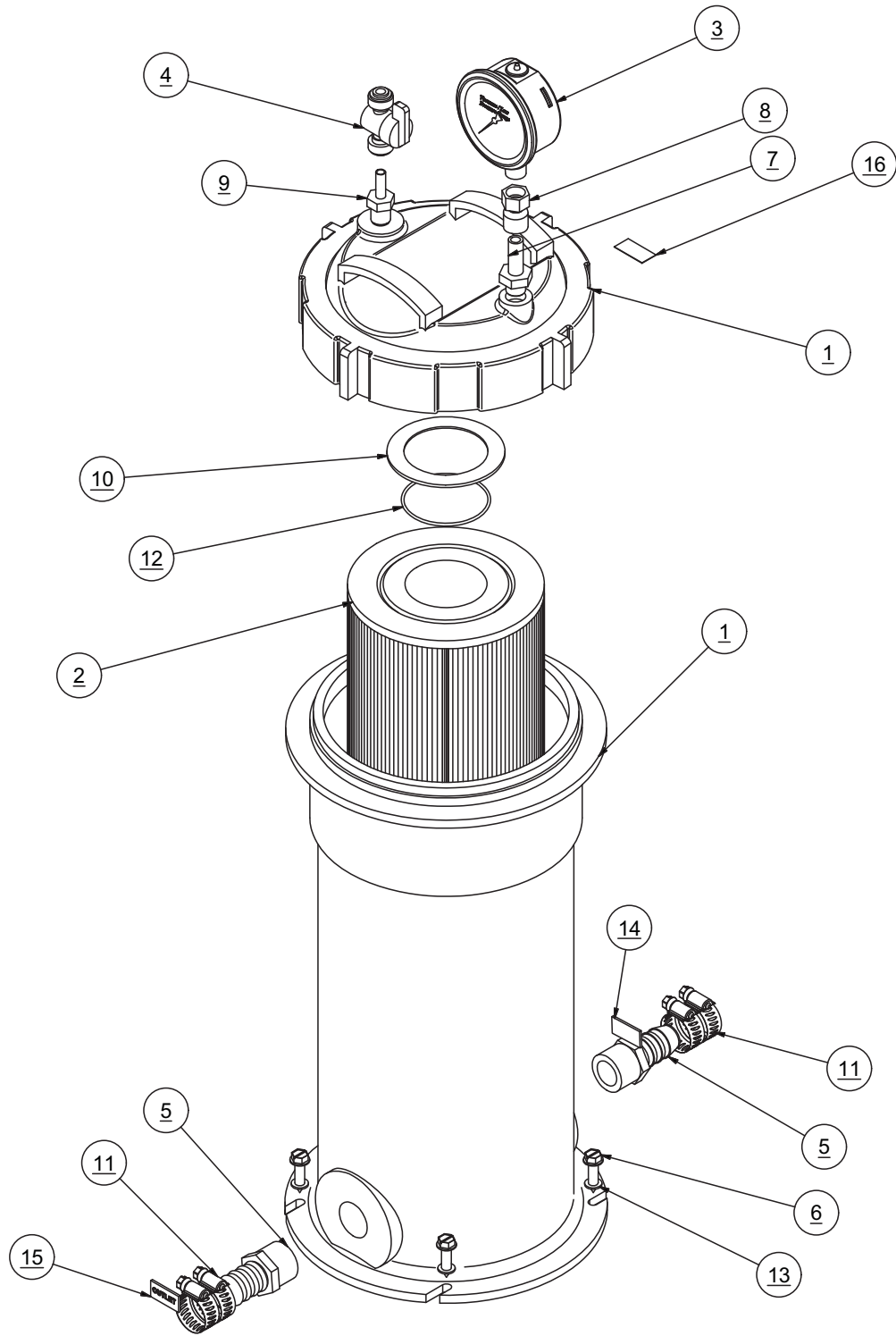

B107230010 OIL WATER SEPARATOR ASSY

ITEM NO.	QTY.	PART NUMBER	DESCRIPTION
1	1	08020723KD	ELEMENT OWSE 32.5 SQFT
2	1	07620310WA	FILTER HOUSING 32.5 SQFT
3	2	0112653706	ADAP .75 MPT X .63 BARB NYLON
4	4	061172143016	SCREX,HEX A,.25x1.00,SS
5	1	0204990300	PLUG .25 JQ
6	4	05181434AA	CLAMP,HOSE,SS,3/4"
7	1	0204020100	ELB90 .25 TUBE JQ x .25MNPT
8	4	061080028000	WASHER FLAT #10 SS
9	1	2213017063	LABEL INLET (WHITE BACKGROUND)
10	1	2213017163	LABEL OUTLET (WHITE BACKGROUND)
11	1	2234010300	LABEL,OIL WATER, SEPARATOR

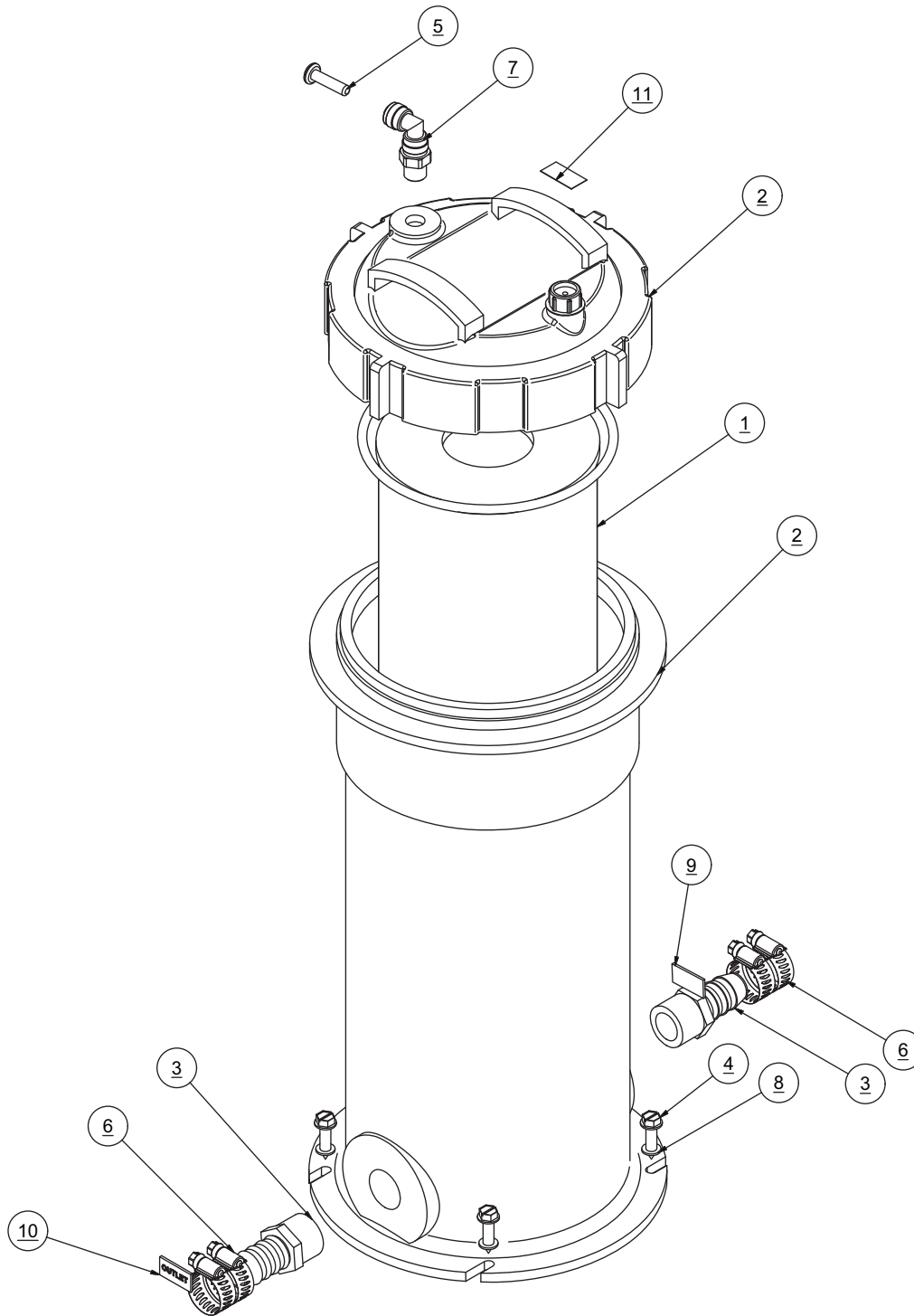

B001220001 INSTALLATION KIT AW/SF 170

ITEM NO.	QTY.	PART NUMBER	DESCRIPTION
1	2	01120125DG	ELB90 1/2 FPT x 1/2FPT NYL
2	2	0112651900	ADAP 3/8 MPT x 1/2 BARB NYL
3	1	0112652500	ADAP 1/2 MPT X 1/2 BARB NYL
4	2	0112653600	ADAP 3/4 MPT X 1/2 BARB NYL
5	1	0204020869	ELB90 1/4 MPT X 1/4 TU PLASTIC
6	1	0204091969	CONN 1/2 MPT X 3/8 TU PLASTIC
7	30 FEET	0312121969	TUBE 1/4 BLACK NYL
8	20 FEET	0312123569	TUBE 3/8 BLACK
9	20 FEET	0328065066	HOSE 1/2 CLEAR BRAID PVC FLEX
10	1	0421056739	SEA STRAINER 3/4 BRONZE
11	8	05181432AA	CLAMP HOSE 1/2 316 SS
12	5	061080028000	WASHER FLAT# 10 ss
13	8	06110043000	WASHER FLAT OS 1/4 SS
14	5	061170628016	SC PHIL PAN "A" #10X 1" L SS
15	8	061172143016	SC HEX "A" 1/4 X 1" L SS

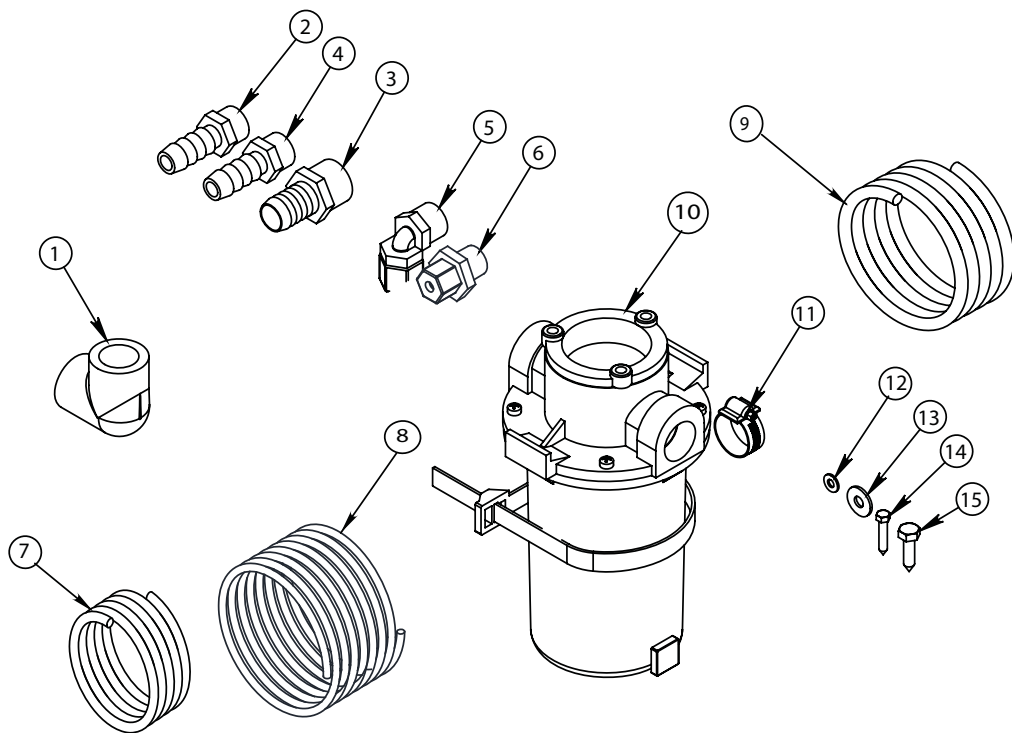

B001230001 INSTALLATION KIT AW/SF 350-750

ITEM NO.	QTY.	PART NUMBER	DESCRIPTION
1	1	01120125DG	ELB90 1/2 FPT X 1/2 FPT NYL
2	1	01120137DG	ELB90 3/4 FPT X 3/4 FPT NYL
3	1	0112653706	ADAP 3/4 MPT X 5/8 BARB NYL
4	1	0112652506	ADAP 1/2 MPT X 5/8 BARB NYL
5	1	0204091969	CONN 1/2 MPT X 3/8 TU PLASTIC
6	1	0204092669	CONN 3/4 MPT X 1/2 TU PLASTIC
7	1	0421056739	SEA STRAINER 3/4 BRONZE
8	2	0112023706	ELB90 3/4 MPT X 5/8 BARB NYL
9	16	05181434AA	CLAMP HOSE 3/4 316 SS
10	30 FEET	0339076100	HOSE HD 5/8 CLR BRAID NYL REIN
11	20 FEET	0312121969	TUBE 1/4 BLACK NYL
12	30 FEET	0312124269	TUBE 1/2 BLACK NYL NO SUBSTITUTE
13	30 FEET	0312123569	TUBE 3/8 BLACK
14	5	061080028000	WASHER FLAT #10 SS
15	5	061170628016	SC PHIL PAN "A" # 10 X 1" L SS
16	12	061172143016	SC HEX "A" 1/4 X 1" L SS
17	12	061100043000	WASHER FLAT OS 1/4 SS

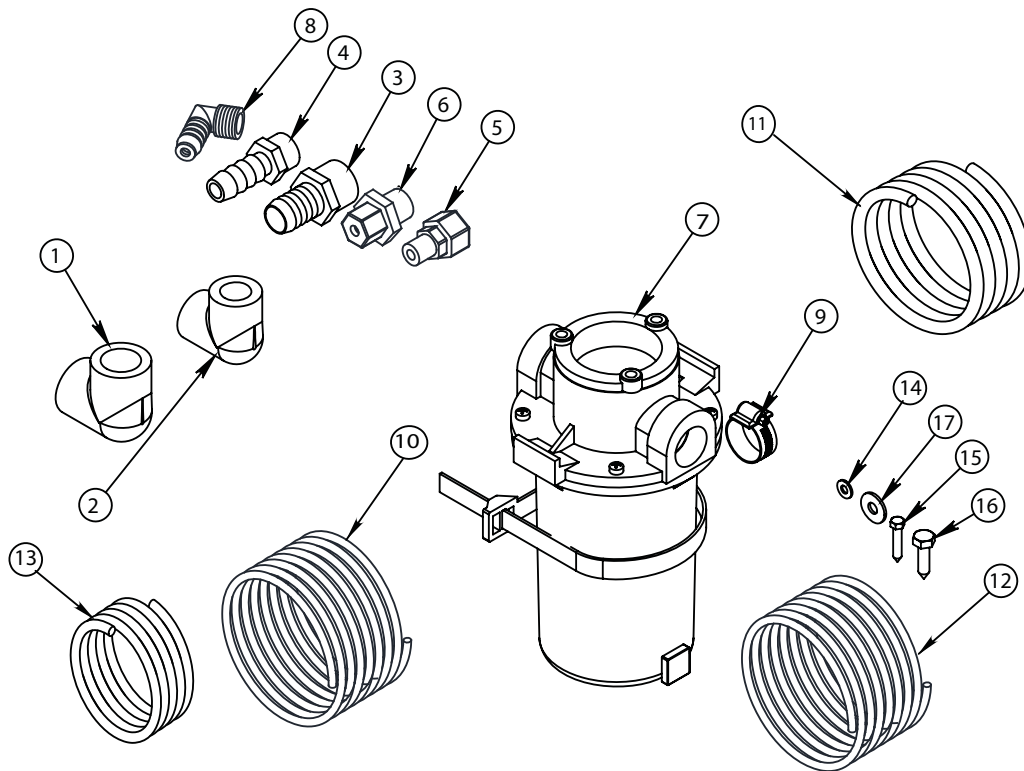

B611000004 REMOTE ASSY LCD CONTROLLER 80' SRC

ITEM NO.	QTY.	PART NUMBER	DESCRIPTION
1	1	4900283104	CABLE MULTIST 8 CON WHT
2	1	3131100900	EZ PLUG RJ45
3	1	31315606WE	REMOTE TOUCH PAD 170

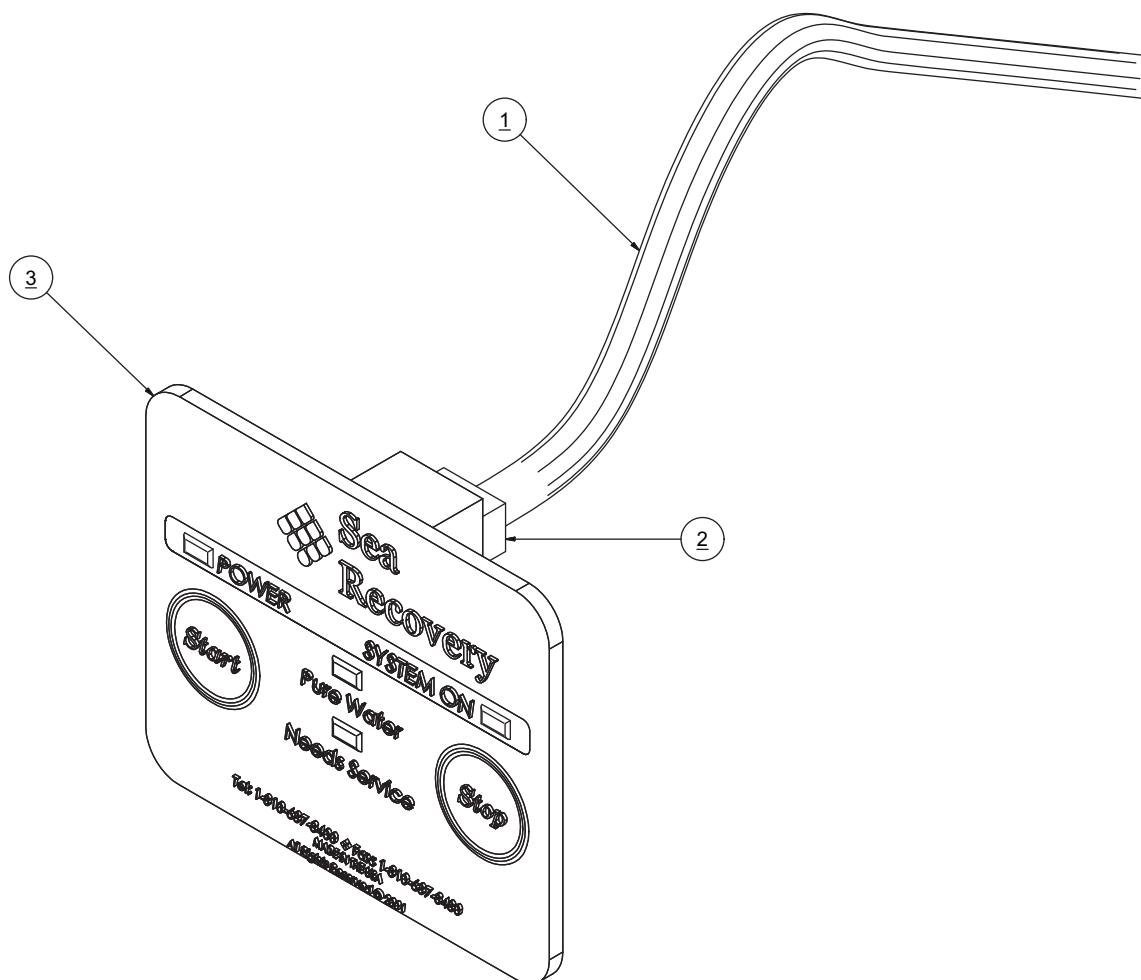

B5262000CV UV STERILIZER

ITEM NO.	QTY.	PART NUMBER	DESCRIPTION
1	2	20010418001A	BRACKET MNT SADDLE UV-AW TOP
2	2	20010418002A	BRACKET MNT SADDLE UV-AW BTM
3	1	40000306CV	UV STERILIZER 2 GPM 12VDC
4	2	0204021769	ELB90 .375 TUBE x .25 MNPT PLASTIC
5	1	0204091869	FITTING,PP,3/8 ODx3/8 MT
6	2	0254011000	ELB90 0.25 MPT X 0.50BARB NY
7	4	05181432AA	CLAMP,HOSE,SS,1/2"
8	2	061100043000	WASHER,FLAT,OS,1/4",SS
9	2	061142145020	SCREW,HEX HEAD,.25-20x1-1/4",SS
10	4	061160630048	SC PHIL PAN # 10-24 X 3.00 SS
11	2	061182143024	SC LAG 0.25 X 1.50 SS
12	2	065070045000	NUT HEX .25-20 FLANGED
13	4	065080028000	WASHER FLAT #10 NYLON
14	2	2614019000	O-RING 212 QUARTZ SLEEVE
15	1	B651830001A	OWNERS MANUAL QUICK INSTALLATION UV LIGHT SP SERIES

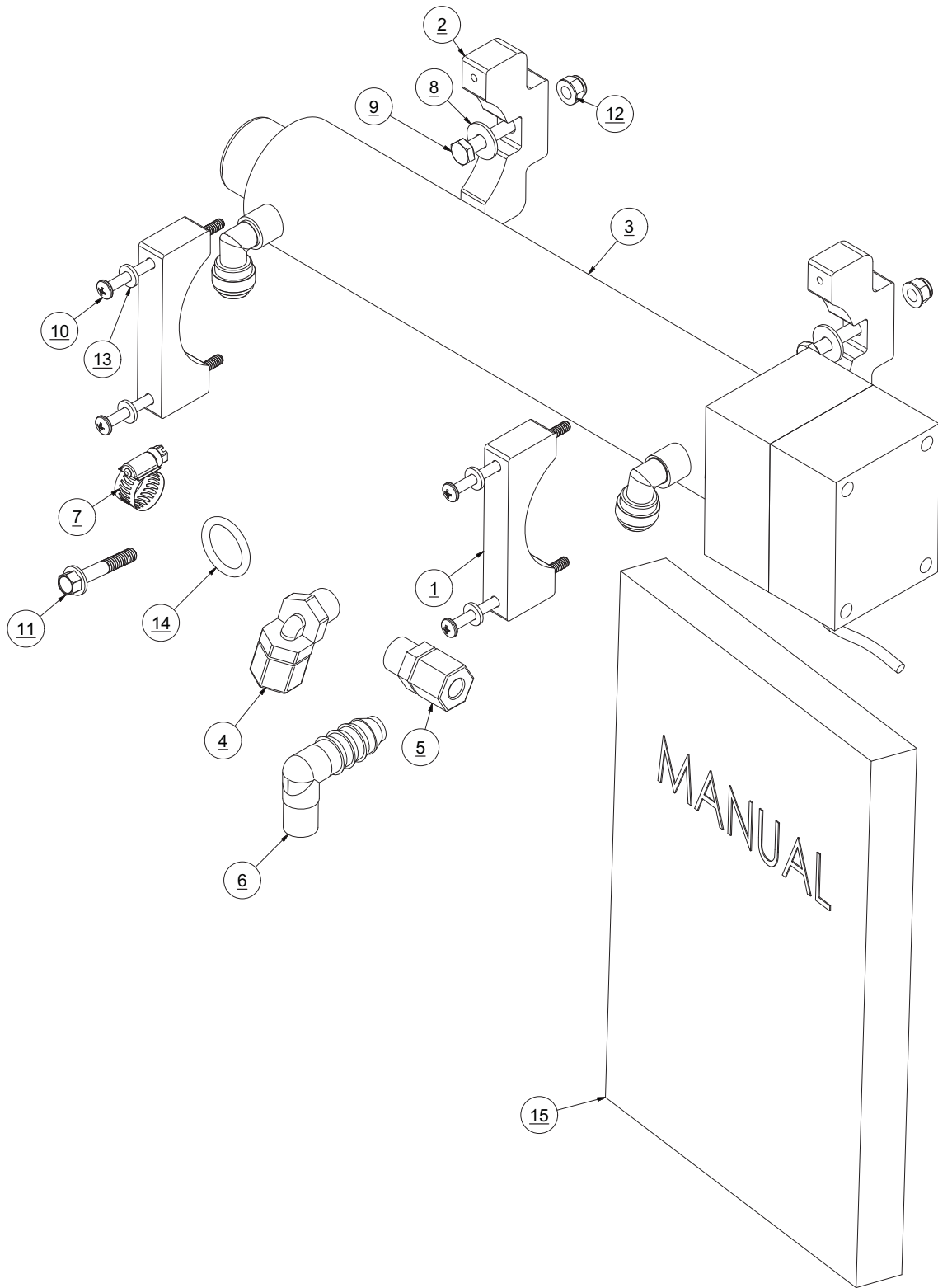

B5968000XX SOFT START ASSY 115-230 V

ITEM NO.	MANUAL ASSY DWG/QTY.	PART NUMBER	DESCRIPTION
1	1	B596800015	SOFT START 115V 50-60HZ
1	1	B596800014	SOFT START 230V 50-60HZ



Note: PLEASE SPECIFY VOLTAGE WHEN ORDERING

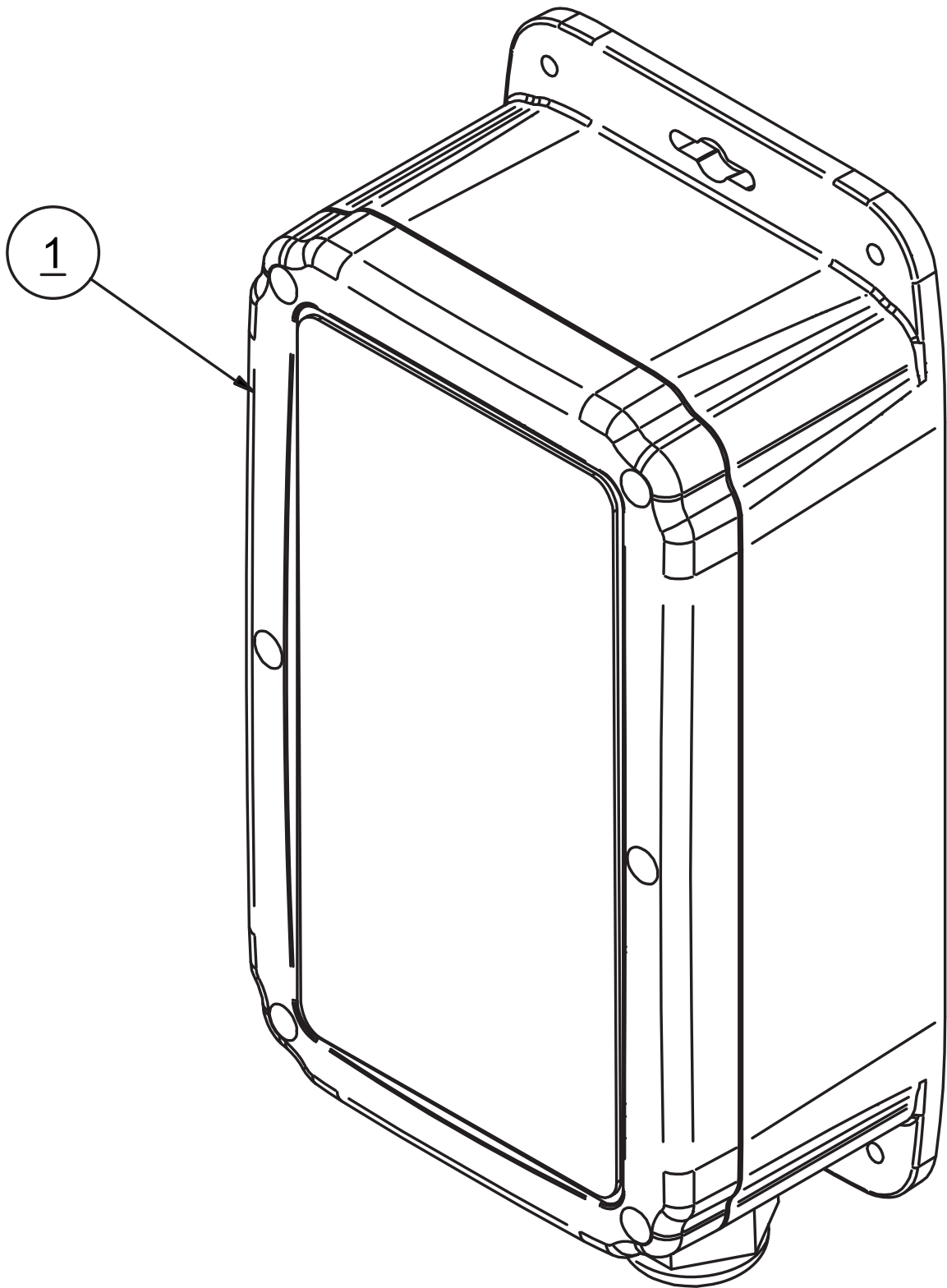

HP HOSE ASSEMBLY

ITEM NO.	QTY.	PART NUMBER	DESCRIPTION
1	1	2432160669	HOSE HP - 6P
2	2	1317481969	SWIVEL FITTING - 6 SSP

*SPECIFY PART NUMBER AND DESCRIPTION OF SPECIFIC HIGH PRESSURE HOSE ASSEMBLY
OR IF A SPECIAL LENGTH IS REQUIRED, SPECIFY MEASURED OVERALL LENGTH: FITTING TO FITTING*

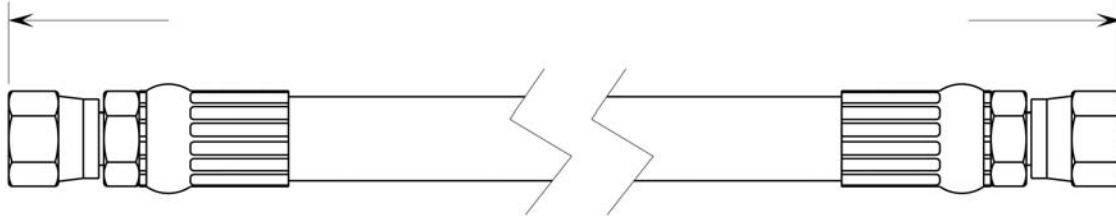

OVERALL LENGTH IS + / - 1/4" (6mm)

AVAILABLE TUBES AND FITTINGS

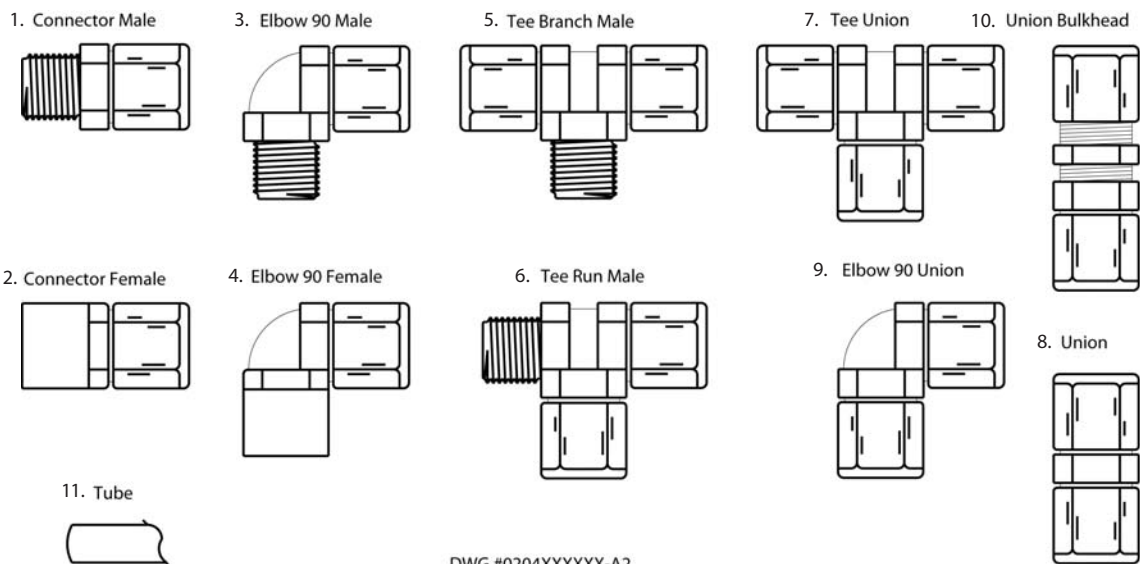

DWG #0204XXXXXX-A2

PART NO	DESCRIPTION
1. CONNECTOR MALE	
0204090669	1/4 inch tube x 1/8 inch mnpt
0204090869	1/4 inch tube x 1/4 inch mnpt
0204091669	3/8 inch tube x 1/8 inch mnpt
0204091769	3/8 inch tube x 1/4 inch mnpt
0204091869	3/8 inch tube x 3/8 inch mnpt
0204091969	3/8 inch tube x 1/2 inch mnpt
0204092069	3/8 inch tube x 3/4 inch mnpt
0204092269	1/2 inch tube x 1/8 inch mnpt
0204092369	1/2 inch tube x 1/4 inch mnpt
0204092469	1/2 inch tube x 3/8 inch mnpt
0204092569	1/2 inch tube x 1/2 inch mnpt
0204092669	1/2 inch tube x 3/4 inch mnpt
0204099069	5/8 inch tube x 1/8 inch mnpt
0204099169	5/8 inch tube x 1/4 inch mnpt
0204092869	5/8 inch tube x 3/8 inch mnpt
0204092969	5/8 inch tube x 1/2 inch mnpt
0204093169	5/8 inch tube x 3/4 inch mnpt
2. CONNECTOR FEMALE	
0204120669	1/4 inch tube x 1/8 inch fnpt
0204120869	1/4 inch tube x 1/4 inch fnpt
0204121769	3/8 inch tube x 1/4 inch fnpt
0204121869	3/8 inch tube x 3/8 inch fnpt
0204121969	3/8 inch tube x 1/2 inch fnpt
0204122569	1/2 inch tube x 1/2 inch fnpt
0204122669	1/2 inch tube x 3/4 inch fnpt

PART NO	DESCRIPTION
0204122969	5/8 inch tube x 1/2 inch fnpt
3. ELBOW 90 MALE	
0204020669	1/4 inch tube x 1/8 inch mnpt
0204020869	1/4 inch tube x 1/4 inch mnpt
0204020969	1/4 inch tube x 3/8 inch mnpt
0204021769	3/8 inch tube x 1/4 inch mnpt
0204021869	3/8 inch tube x 3/8 inch mnpt
0204021969	3/8 inch tube x 1/2 inch mnpt
0204022069	3/8 inch tube x 3/4 inch mnpt
0204022469	1/2 inch tube x 3/8 inch mnpt
0204022569	1/2 inch tube x 1/2 inch mnpt
0204022969	5/8 inch tube x 1/2 inch mnpt
4. ELBOW 90 FEMALE	
0204010669	1/4 inch tube x 1/8 inch fnpt
0204010869	1/4 inch tube x 1/4 inch fnpt
0204011769	3/8 inch tube x 1/4 inch fnpt
0204011869	3/8 inch tube x 3/8 inch fnpt
0204012469	1/2 inch tube x 3/8 inch fnpt
0204012569	1/2 inch tube x 1/2 inch fnpt
0204012969	5/8 inch tube x 1/2 inch fnpt
5. BRANCH TEE MALE	
0204150669	1/4 inch tube x 1/8 inch mnpt
0204151769	3/8 inch tube x 1/4 inch mnpt
0204152469	1/2 inch tube x 3/8 inch mnpt
0204152969	5/8 inch tube x 1/2 inch mnpt
6. RUN TEE MALE	
0204170669	1/4 inch tube x 1/8 inch mnpt
0204170869	1/4 inch tube x 1/4 inch mnpt
0204171769	3/8 inch tube x 1/4 inch mnpt
0204171869	3/8 inch tube x 3/8 inch mnpt
0204172469	1/2 inch tube x 3/8 inch mnpt
0204172569	1/2 inch tube x 1/2 inch mnpt
0204172969	5/8 inch tube x 1/2 inch mnpt
7. UNION TEE	
0204240869	1/4 inch tube
0204241869	3/8 inch tube
0204242469	1/2 inch tube x 3/8 inch tube
0204242569	1/2 inch tube
0204242869	5/8 inch tube x 3/8 inch tube
0204243069	5/8 inch tube
8. UNION	
0204210869	1/4 inch tube
0204211769	3/8 inch tube x 1/4 inch tube

PART NO	DESCRIPTION
0204211869	3/8 inch tube
0204212469	1/2 inch tube x 3/8 inch tube
0204212569	1/2 inch tube
0204212869	5/8 inch tube x 3/8 inch tube
0204212969	5/8 inch tube x 1/2 inch tube
0204213069	5/8 inch tube
9. UNION ELBOW 90	
0204220869	1/4 inch tube
0204221769	3/8 inch tube x 1/4 inch tube
0204221869	3/8 inch tube
0204222569	1/2 inch tube
0204223069	5/8 inch tube
10. UNION BULKHEAD	
0204270869	1/4 inch tube
0204271869	3/8 inch tube
0204272569	1/2 inch tube
11. TUBE	
0312122969	1/4 inch tube Black Nylon
0306152969	1/4 inch tube Blue Polypropylene
0306142969	1/4 inch tube Red Polypropylene
0312124169	3/8 inch tube Black Nylon
0306154169	3/8 inch tube Blue Polypropylene
0306144169	3/8 inch tube Red Polypropylene
0312125069	1/2 inch tube Black Nylon
0305125869	5/8 inch tube Black Polypropylene

TUBE COMPRESSION FITTINGS REPLACEMENT PARTS

ITEM	DESCRIPTION	PART NO.
FOR 1/4" O.D. TUBE		
1	NUT/SPACER/GRAB & O-RING 1/4"	0204-1/469
2	TUBE 1/4 BLACK	0312121969
FOR 3/8" O.D. TUBE		
1	NUT/SPACER/GRAB & O-RING 3/8"	0204-3/869
2	TUBE 3/8 BLACK	0312123569
FOR 1/2" O.D. TUBE		
1	NUT/SPACE/GRAB & O-RING 1/2"	0204-1/269
2	TUBE 1/2 BLACK NO SUBSTITUTE	0312124269
FOR 5/8" O.D. TUBE		
1	NUT/SPACER/GRAB & O-RING 5/8"	0204-5/869
2	TUBE 5/8 BLACK POLYPRO	0305125169

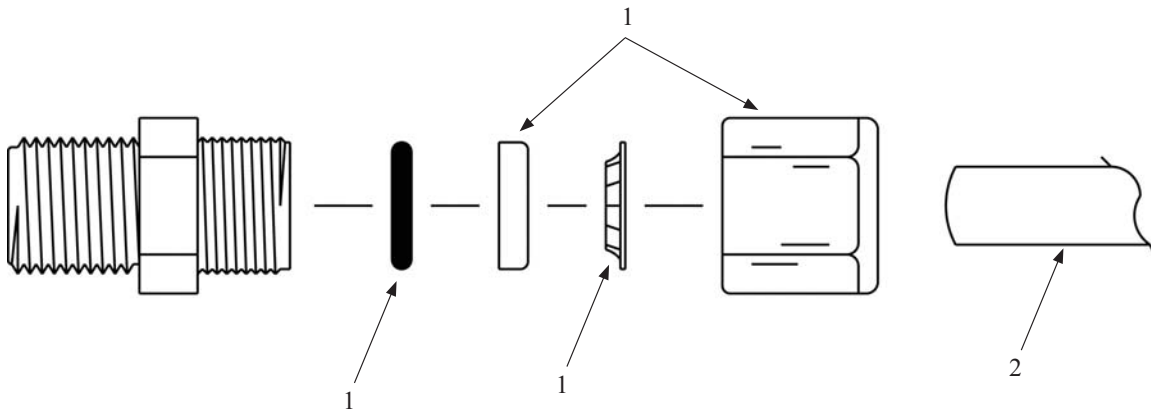

Clean/Rinse Inlet Valve

CLEAN/RINSE INLET VALVE

CLEAN / RINSE INLET VALVE

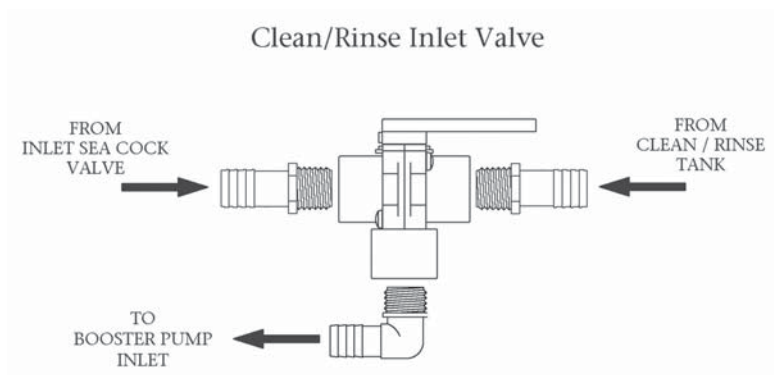

CLEAN / RINSE OUTLET VALVE

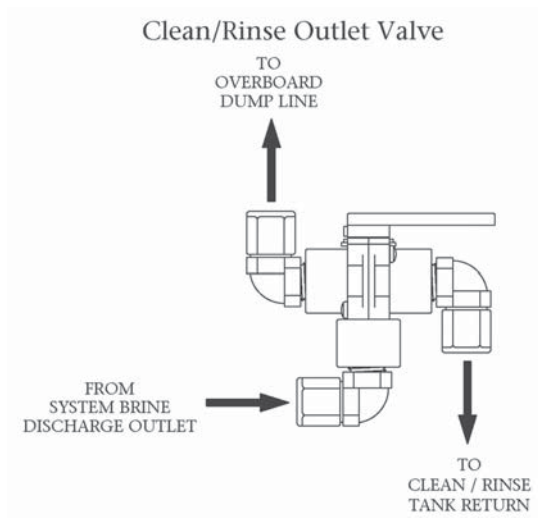

Chapter 13

Appendix



CERTIFICATE NUMBER

05-HS122694E-PDA

DATE

17 October 2005

ABS TECHNICAL OFFICE

Houston SED - Ship Systems

CERTIFICATE OF Design Assessment

This is to Certify that a representative of this Bureau did, at the request of
Sea Recovery Corporation

assess design plans and data for the below listed product. This assessment is a representation by the Bureau as to the degree of compliance the design exhibits with applicable sections of the Rules. This assessment does not waive unit certification or classification procedures required by ABS Rules for products to be installed in ABS classed vessels or facilities. This certificate, by itself, does not reflect that the product is Type Approved. The scope and limitations of this assessment are detailed on the pages attached to this certificate. It will remain valid for five years from the date of issue or until the Rules or specifications used in the assessment are revised (whichever occurs first).

PRODUCT: Reverse Osmosis Desalinator
MODEL: Aqua Whisper Series
ABS RULE: 2005 Steel Vessel Rules 1-1-4/7.7, 4-6-2/5.7
OTHER STANDARD: None;

AMERICAN BUREAU OF SHIPPING

Hans P. Haendler

Engineering Type Approval Co-ordinator

Sea Recovery Corporation

P. O. Box 5288
Carson
California 90745-5288
United States of America
Telephone: 310-637-3400
Fax: 310-637-3430

Plant Address:
19610 S. Rancho Way
Rancho Dominguez, California
90220

MA Certificate No. 936687-644289-01

Product: Reverse Osmosis Desalinator

Model: Aqua Whisper Series

Intended Service:

Production of Fresh Water by Sea Desalination

Description:

Reverse Osmosis Desalination Unit

Ratings:

Model: SRC 450: Rating Gallons Per Day (GPD): 450; Model: SRC 700: Rating (GPD): 700; Model: SRC 900: Rating (GPD): 900; Model: SRC 1400: Rating (GPD): 1400; Model: SRC 1800: Rating (GPD): 1800

Service Restrictions:

Unit Certification is not required for this product.

Comments:

1) If the system is to be installed on a US Flag Vessel, the hoses and associated fittings are to be manufactured to SAE J1942 standard and are to be suitable for the intended application; 2) The use of PVC piping is limited to 225 psi for water application.

Term of Validity:

This product/model is covered under Product Design Assessment (PDA) Certificate # 05-HS122694E/1-PDA, dated 12/Jan/2006. This PDA Certificate expires Jan of 2011. It will remain valid for the 5 years from date of issue or until the Rules or specifications used in the assessment are revised (whichever occurs first).

STANDARDS

ABS Rules:

2006 Steel Vessel Rules 1-1-4/7.7, 4-6-2/5.7

Others:

None

FCC Compliance

Statement of Compliance

Presented to
Sea Recovery Corporation

The following model was tested and found to be fully compliant with FCC/CISPR 22/85 Class A (ANSI C63.4 1992), EN55011 Class A Group 1 (1991) & EN50082-2 (1995)

Water Desalinator, AW Series

Tested at CKC Laboratories, Inc. on September 28-29, 1998
Report Number: FA98-126 & CE98-254

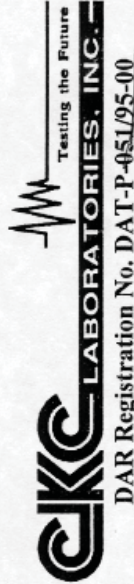

Dennis Ward

Dennis Ward
Director of Laboratories

Tracy Phillips

Tracy Phillips
Documentation Control Supervisor



Confirmation of Product Type Approval 07/SEP/2011

Please refer to the "Service Restrictions" shown below to determine if Unit Certification is required for this product.

This is to certify that, pursuant to the Rules of the American Bureau of Shipping (ABS), the manufacturer of the below listed product held a valid Manufacturing Assessment (MA) with expiration date of 19/MAY/2014. The continued validity of the Manufacturing Assessment is dependent on completion of satisfactory audits as required by the ABS Rules.

And; a Product Design Assessment (PDA) valid until 22/NOV/2015 subject to continued compliance with the Rules or standards used in the evaluation of the product.

The above entitle the product to be called Product Type Approved.

The Product Design Assessment is valid for products intended for use on ABS classed vessels, MODUs or facilities which are in existence or under contract for construction on the date of the ABS Rules used to evaluate the Product.

ABS makes no representations regarding Type Approval of the Product for use on vessels, MODUs or facilities built after the date of the ABS Rules used for this evaluation.

Due to wide variety of specifications used in the products ABS has evaluated for Type Approval, it is part of our contract that; whether the standard is an ABS Rule or a non-ABS Rule, the Client has full responsibility for continued compliance with the standard.

SEA RECOVERY Model Name(s): Aqua Mini

Presented to:

DANFOSS SEA RECOVERY
19610 S. RANCHO WAY
RANCHO DOMINGUEZ
United States

Intended Service:	Marine & Offshore Application - Production of Fresh Water by Sea Desalination
Description:	Reverse Osmosis Desalination Unit
Ratings:	Model: Aqua Mini 170 GPD, Aqua Mini 350 GPD, Aqua Mini 550 GPD, Aqua Mini 705 GPD.
Service Restrictions:	Unit Certification is not required for this product. If the manufacturer or purchaser request an ABS Certificate for compliance with a specification or standard, the specification or standard, including inspection standards and tolerances, must be clearly defined.
Comments:	1) If the system is to be installed on a US Flag Vessel, the hoses and associated fittings are to be manufactured to SAE J1942 standard and are to be suitable for the intended application; 2) The use of PVC piping is limited to 50 psi for water application.
Notes / Documentation:	Supporting Documentation: Drawing No. A222000170 Rev. 0 Aqua Mini 170 GPD Frame. Spec and dimensions.
Term of Validity:	This Product Design Assessment (PDA) Certificate 05-HS122694A-2-PDA, dated 23/Nov/2010 remains valid until 22/Nov/2015 or until the Rules or specifications used in the assessment are revised (whichever occurs first). This PDA is intended for a product to be installed on an ABS classed vessel, MODU or facility which is in existence or under contract for construction on the date of the ABS Rules or specifications used to evaluate the Product. Use of the Product on an ABS classed vessel, MODU or facility which is contracted after the validity date of the ABS Rules

and specifications used to evaluate the Product, will require re-evaluation of the PDA. Use of the Product for non ABS classed vessels, MODUs or facilities is to be to an agreement between the manufacturer and intended client.

ABS Rules: 2010 Steel Vessels Rules 1-1-4/7.7, 1-1-Appendix 3, 4-6-2/5.7, 4-6-2/5.7
National Standards:
International Standards:
Government Authority:
EUMED:
Others: None

Model Certificate	Model Certificate No	Issue Date	Expiry Date
PDA	05-HS122694A-2-PDA	23/NOV/2010	22/NOV/2015



ABS Programs

ABS has used due diligence in the preparation of this certificate and it represents the information on the product in the ABS Records as of the date and time the certificate was printed. Type Approval requires Drawing Assessment, Prototype Testing and assessment of the manufacturer's quality assurance and quality control arrangements. Limited circumstances may allow only Prototype Testing to satisfy Type Approval. The approvals of Drawings and Products remain valid as long as the ABS Rule, to which they were assessed, remains valid. ABS cautions manufacturers to review and maintain compliance with all other specifications to which the product may have been assessed. Further, unless it is specifically indicated in the description of the product; Type Approval does not necessarily waive witnessed inspection or survey procedures (where otherwise required) for products to be used in a vessel, MODU or facility intended to be ABS classed or that is presently in class with ABS. Questions regarding the validity of ABS Rules or the need for supplemental testing or inspection of such products should, in all cases, be addressed to ABS.

Declaration of Conformity

CE

SEA RECOVERY declares that the following models conform to the EN 55011A and EN 50082-2 standards:

Product Series:

Aqua Matic Series
Aqua Whisper Series
Aqua Whisper Mini Series
Ultra Whisper Series
Coral Sea Series

Model Names:

Aqua Matic
Aqua Whisper / DX
Aqua Whisper Mini
Ultra Whisper
Coral Sea



Manufacturer's Name:
Sea Recovery
Manufacturer's Address:
19610 South Rancho Way
Rancho Dominguez, CA 90220
U.S.A.



Official Seal

Supplementary Information:

"The product complies with the Requirements of the EMC Directive 89/336/EEC."

A handwritten signature in black ink that reads "Lisa Gomez".

Lisa Gomez
Quality & Environmental Manager
Manufacturer's Contact



Sea Recovery
2630 E. El Presidio Street
Carson, CA 90810
sales@searecovery.com

www.searecovery.com