

### Manual Diaphragm Pumps

These are the traditional mainstay of small craft bilge pumping systems and can offer surprisingly good flow rates, as well as a variety of installation options. Yacht racing rules state that at least one pump must be capable of being pumped from the cockpit with all hatches shut. The best way to accomplish this is with a through deck kit which allows the pump to be installed safely below decks while the operator pumps from above.

A well designed manual bilge pump is very hard to block due to its large bore hose and valves and one piece diaphragm. The larger pumps in Jabsco's line of manual bilge pumps are also suitable for ballast and waste transfer.

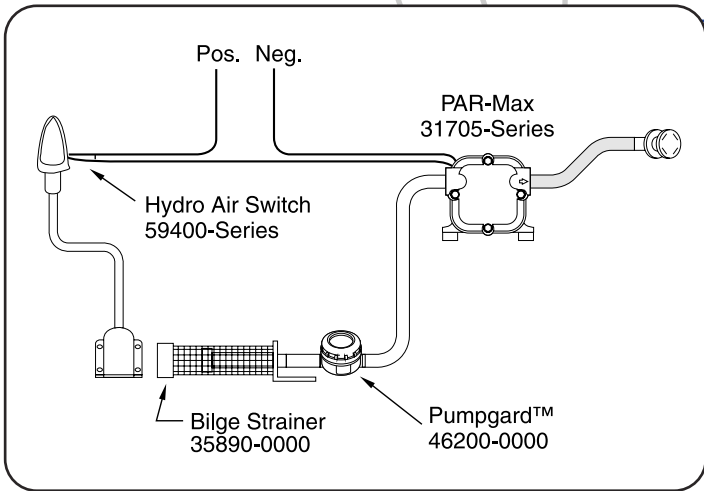

### Electric Diaphragm Pumps

These pumps are excellent for shallow bilge boats where the water left behind by other types of pumps will slop from side to side. With the small size of inlet plumbing they are very effective as bilge pumps, removing all but the last drops of water. Diaphragm pumps can be run dry which removes the need to watch overboard outlets while the pump is running. The ability to self-prime means they can be mounted in an easily accessible high and dry location to simplify installation and improve serviceability. Most models in the line are supplied complete with a Pumpgard™ strainer to protect the pumps from bilge debris.



#### WARNING

No pump manufactured by Jabsco should be used for gasoline, petroleum products or any fluid with a flash point below 100°F (38C).



## Electric Flexible Impeller Pumps

Flexible Impeller pumps make excellent bilge pumps, principally because of their ability to handle bilge debris without damage. Because of the robust design many owners still use our 12 Volt dc or 24 Volt dc flexible impeller motor pump units that are up to 25 years old! Flexible Impeller Pumps also give the benefits of good flow, low cost, low size and weight, and are easily serviced and maintained. Most Flexible Impeller pumps must not be run dry, as this will damage the impeller which will require replacing. However, the Utility Puppy 2000 and 3000 both allow a maximum of ten minutes dry running after initial prime. As with submersible pumps, flexible impeller pumps can be operated using a float or Hydro Air switch, and remotely controlled from outside the bilge compartment. There is a wide range of flexible impeller pumps to choose from giving a range of flows, discharge heads, and self-priming options for a wide variety of applications such as ballast transfer, bait tank circulation, and deck wash duties.

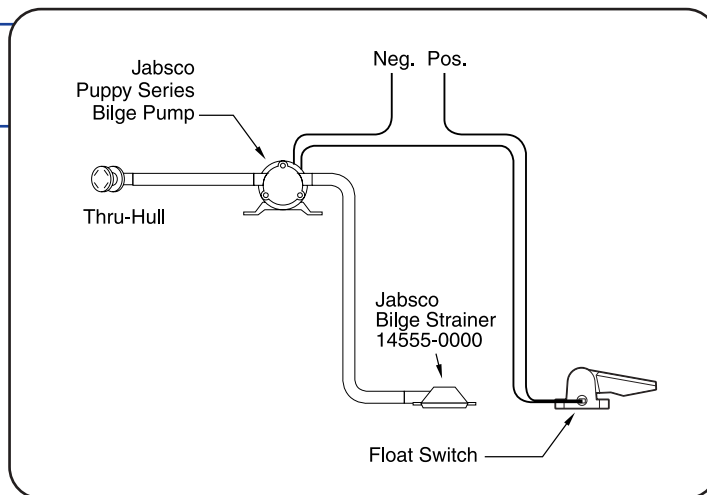

## Engine Driven Flexible Impeller Pumps

Jabsco engine driven pumps are probably the strongest and most reliable pumps produced today. Combined with other benefits such as self-priming and very high flow rates, these pumps are now the firm favorites of commercial and professional mariners world wide. All the pumps are easily maintained and can fulfill a variety of duties on board both modern and classic vessels. Jabsco engine driven pumps come in a very wide range of performances and sizes and can be direct driven by either a clutch, pulley, hydraulic drive, or close coupled to a suitable power take off on the engine. These pumps are suitable for applications such as:

- High flow, heavy duty bilge pumps
- Emergency on board bilge pumps
- Fire fighting pumps
- Engine cooling
- Water Ballast transfer
- Circulation duties

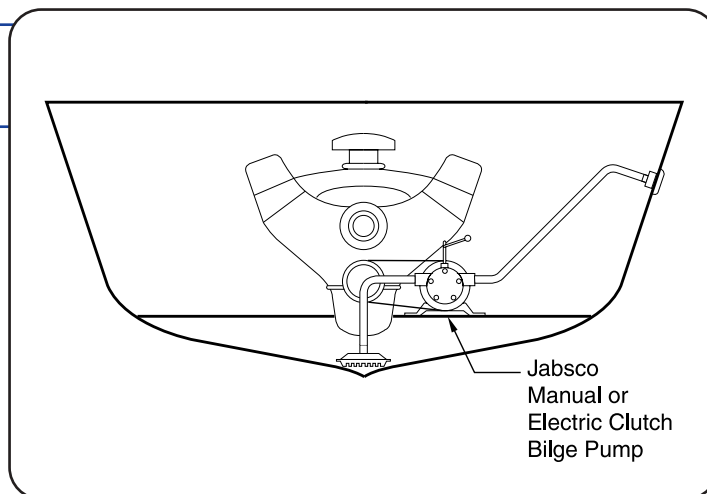

Of course each application requires different features from each pump and drive type. Either manual or electromagnetic flexible impeller clutch pumps are ideal for bilge pumping. Each type of clutch has different benefits from the other. Manual clutches will operate as long as the engines are still running which provides added security when operating as an emergency bilge pump. Electromagnetic clutches can be operated remotely via float or Hydro Air switches, while fitting a vacuum switch eliminates all risk of dry running damage. However, electromagnetic clutches will only engage as long as electrical power remains available.



## Amazon Bulkhead

### For mounting on bulkhead or deck.

- Repositionable ports and body offer an amazing 96 assembly variations.
- Sustainable 12 gpm (45 lpm) output.
- Self-priming up to 13ft (4m).
- Corrosion resistant materials throughout.
- Stainless steel handle supplied with mounting clips and provision for safety lanyard.

**Fitting:** Connections for 1" (25mm) ID hose.

**Size:** 7" wide x 8" deep x 4<sup>3</sup>/<sub>4</sub>" high (18cm x 20cm x 12cm).

**Weight:** 1.4 lb (0.6 kg).

**29240-0000** Bulkhead Pump, c/w detachable handle.

**29246-1000** Service kit.

*For service and spare parts listing see page 163.*

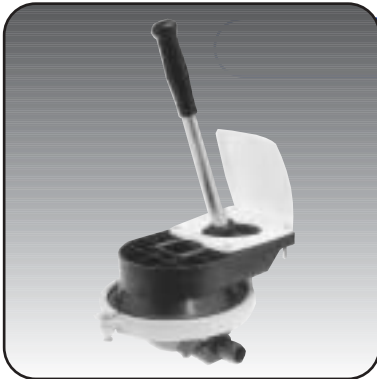

## Amazon ThruDeck

### For mounting through deck or through bulkhead.

- The ultimate compact through deck pump with no less than 16 port variations relative to the body.
- Readily achievable 13 gpm (50 lpm) output.
- Self-priming up to 16ft (5m).
- Loosening just one screw lets you clear blockages or position the body anywhere through 360° relative to the handle position.
- Compact design and low profile allow installation in confined spaces.
- Sleekly styled Through Deck Kit and cover, with 4 mounting positions relative to the pump.
- Excellent solids handling ability for use with holding tanks.

■ Corrosion resistant materials throughout.

■ Stainless steel handle supplied with mounting clips and provision for safety lanyard.

**Fitting:** Connections for 1" (25mm) ID hose or 1<sup>1</sup>/<sub>2</sub>" (38mm) hose.

**Size:** 10" long x 4<sup>5</sup>/<sub>16</sub>" wide x 4<sup>1</sup>/<sub>2</sub>" deep (25cm x 11cm x 12cm).

**Weight:** 2<sup>1</sup>/<sub>2</sub> lbs (1.2 kg).

**29250-0000** 1" (25mm) ThruDeck Pump, with detachable handle and Through Deck Kit.

**29250-0010** 1<sup>1</sup>/<sub>2</sub>" (38mm) ThruDeck Pump, c/w detachable handle and Through Deck Kit.

**29256-1000** Service kit.

*For service and spare parts listing see page 163.*



## Amazon Universal

### For mounting on bulkhead, through bulkhead, on deck or through deck.

- Unique safety feature allows operation from both inside and outside the cabin (with optional Through Deck Kit).
- Flow rate of up to 25 gpm (100 lpm).
- Self-priming up to 10ft (3m).
- Push-fit inlet and outlet elbows swivel through 360° to increase flexibility of installation still further.
- Corrosion resistant materials throughout.
- Quick release clamp ring gives fast access for blockage clearance.
- 1<sup>1</sup>/<sub>2</sub>" (38mm) ports give excellent solids handling ability for use with holding tanks.

■ Stainless steel handle supplied with mounting clips and provision for safety lanyard.

**Fitting:** Connections for 1<sup>1</sup>/<sub>2</sub>" (38mm) ID hose.

**Size:** 9<sup>1</sup>/<sub>2</sub>" wide x 9<sup>1</sup>/<sub>2</sub>" high x 6" deep (24cm x 24cm x 15cm).

**Weight:** 2.9 lb (1.2 kg).

**29270-0000** Universal Pump, with detachable handle and one push-fit elbow.

**29279-0000** Optional Through Deck Kit.

**29266-1000** Additional push-fit elbow.

**29276-1000** Service kit.

*For service and spare parts listing see page 164.*



## Bilge Strainers

### Stop bilge debris blocking inlet suction hose and reduce the risk of debris entering and blocking the pump.

- Available to suit <sup>3</sup>/<sub>4</sub>", 1" and 1<sup>1</sup>/<sub>2</sub>" (19mm, 25mm and 38mm) ID hose.
- Non-return valve fitted to stop bilge water draining back when pumping stops.
- Re-positional ports allow horizontal, vertical or sideways hose attachments.
- Easily removable strainer plate for cleaning.
- Corrosion resistant materials throughout.

**Fitting:** Connections for <sup>3</sup>/<sub>4</sub>", 1" or 1<sup>1</sup>/<sub>2</sub>" (19mm, 25mm or 38mm) ID hose.

**Size:** 6<sup>3</sup>/<sub>4</sub>" long x 2<sup>3</sup>/<sub>4</sub>" wide x 2<sup>1</sup>/<sub>2</sub>" high (17cm x 7.2cm x 6cm).

**Weight:** <sup>1</sup>/<sub>4</sub> lb (0.1 kg).

**29290-1020** Bilge Strainer for <sup>3</sup>/<sub>4</sub>" (19mm) ID hose.

**29290-1000** Bilge Strainer for 1" (25mm) ID hose.

**29290-1010** Bilge Strainer for 1<sup>1</sup>/<sub>2</sub>" (38mm) ID hose.



## Amazon Warrior

**For mounting on deck, or through deck (with optional Through Deck Kit and Bracket).**

- Robust design particularly suited to workboats and larger leisure craft, or any installation where particularly heavy duty use is anticipated.
- 29280-0100 Model with swivel arms and captive wheel nuts meets DTI requirements for use on lifeboats.
- 18" (45cm) handle assists sustained high outputs of up to 35 gpm (135 lpm).
- Self-priming up to 17.5ft (5.5m).
- Double diaphragm design gives maximum efficiency, and added safety.
- 1 1/2" (38mm) ports give large solids handling ability.

- Can function on one diaphragm in an emergency.
- Corrosion resistant materials throughout.

**Fitting:** Connections for 1 1/2" (38mm) ID hose.

**Size:** 14" wide x 9 1/2" high x 8" deep (35.5cm x 24cm x 20cm).

**Weight:** 11 lbs (4.95 kg).

- 29280-0000** Warrior Pump, with detachable handle.
- 29280-0100** Warrior Pump, lifeboat version.
- 29279-0000** Optional Through Deck Kit.
- 29289-0000** Under Deck Bracket (required for use with Through Deck Kit).
- 29286-1000** Service kit.

*For service and spare parts listing see page 164.*



## In-Line Non-Return Valves

**Non-return valves fit in a pump's suction hose to aid priming and prevent backflow of water into the bilges.**

- Available for three hose sizes - 3/4", 1" and 1 1/2" (19mm, 25mm and 38mm).
- Simply fit into suction hose.
- Corrosion resistant materials throughout.

**Fitting:** Connections for 3/4", 1" or 1 1/2" (19mm, 25mm or 38mm) ID hose.

**Size:** 4 1/4" long x 2 1/8" wide x 2" high (10.8cm x 5.5cm x 5cm).

**Weight:** 1/4 lb (0.1 kg).

- 29295-1011** In-Line non-return valve for 3/4" (19mm) ID hose.
- 29295-1000** In-Line non-return valve for 1" (25mm) ID hose.
- 29295-1010** In-Line non-return valve for 1 1/2" (38mm) ID hose.



## Amazon Mounting Positions

### Amazon Bulkhead

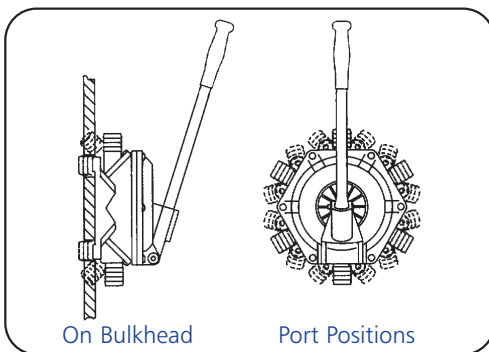

### Amazon Thru Deck

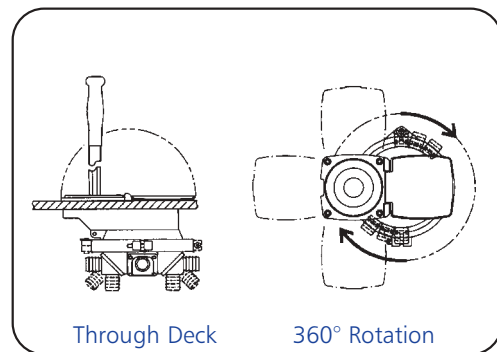

### Amazon Universal

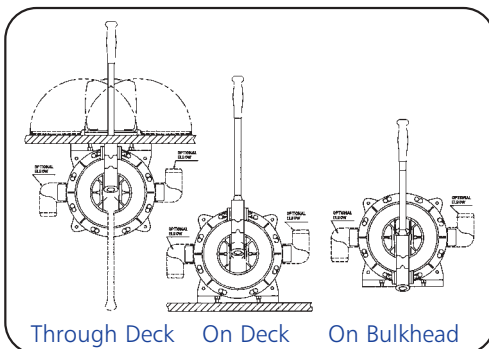

### Amazon Warrior

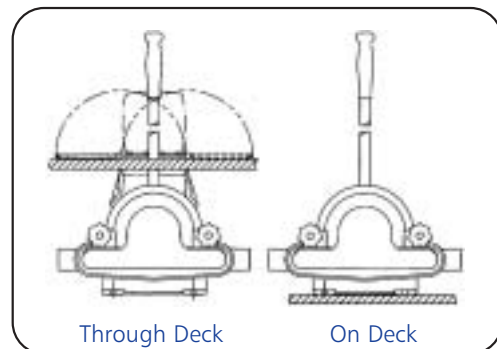

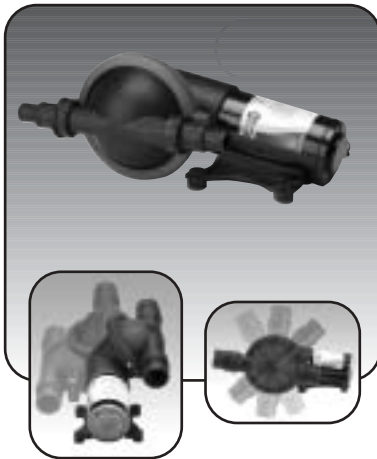

## 50880 Series Bilge Pump

**Robust diaphragm pump suitable for bilge applications with a multi-positional pump head.**

- 4.2 gpm (16 lpm) open flow output at 3ft (1m) head.
- Self-priming up to 10ft (3m) vertical lift allows mounting above wet bilges.
- Flexible Installation.
- Compact and simple design.
- Filter-less.
- Quiet running.
- Capable of extensive dry running.
- Corrosion resistant parts.

- Complies with USCG 183.410 and ISO 8846 MARINE (ignition protection).

- ISO 8849 MARINE (Bilge Pump Standard).

**Fitting:** Connections for 3/4" (19mm) ID Hose

**Size:** 11.7" long x 5.9" wide x 4.4" high (29.7cm x 15cm x 11.1cm)

**Weight:** 6lb (2.7kg)

**50880-1000** 12 Volt dc model, fuse 10 amp

**50880-1100** 24 Volt dc model, fuse 5 amp

**SK880** Service Kit

*For service and spare parts listing see page 153.*



## PAR-Max 4 31705

**New generation, continuous rated bilge pump with waterproof coating for harsh environments.**

- 258 usgph (978 lph) open flow output
- Self-priming up to 10ft (3m) allows mounting above wet bilges.
- Diaphragm design allows extended dry running.
- Build-in thermal overload protection.
- Complete with Pumpgard™ strainer.
- Complies with USCG 183.410 and ISO 8846 MARINE (ignition protection).
- ISO 8849 MARINE (Bilge Pump Standard).

**Fitting:** Connections for 3/4" (19mm) ID hose.

**Size:** 7 1/4" long x 4 1/8" wide x 4 1/10" high (18cm x 10.5cm x 10cm).

**Weight:** 5.5 lb (2.5 kg).

**31705-0092** 12 Volt dc, fuse 10 amp.

**31705-0094** 24 Volt dc, fuse 7 amp.

**18912-3050** Diaphragm kit

*For service and spare parts listing see page 161.*



## 37202 Series 2

**Quiet running and corrosion resistant bilge, shower and sink drain pump.**

- 200 usgph (780 lph) open flow output.
- Self-priming up to 6ft (2m) vertical lift.
- Diaphragm design allows extended dry running.
- Complete with Pumpgard™ pre-filter.
- Complies with USCG 183.410 and ISO 8846 MARINE (ignition protection).
- ISO 8849 MARINE (Bilge Pump Standard).

**Fitting:** Connections for 3/4" (19mm) ID hose.

**Size:** 5 1/4" wide x 5 3/4" high x 7 1/2" deep (13cm x 15cm x 19cm).

**Weight:** 5 1/2 lb (2.5 kg).

**37202-2012** 12 Volt dc model, fuse 10 amp.

**37202-2024** 24 Volt dc model, fuse 5 amp.

**50095-1000** Service kit

*For service and spare parts listing see page 152.*



## PAR 36680

**Fully serviceable, bilge and deckwash pump.**

- 330 usgph (1250 lph) open flow output.
- Self-priming up to 7ft (2m) vertical lift, allows mounting above wet bilges.
- Diaphragm design allows extended dry running.
- Complete with Pumpgard™ strainer.
- Complies with USCG 183.410 and ISO 8846 MARINE (ignition protection).
- ISO 8849 MARINE (Bilge Pump Standard).

**Fitting:** Connections for 3/4" (19mm) ID hose.

**Size:** 7 3/8" long x 6 1/2" wide x 8 1/2" high (19.4cm x 16.5cm x 21.6cm).

**Weight:** 8 lb (6 kg).

**36680-2000** 12 Volt dc model, fuse 10 amp.

**36680-2010** 24 Volt dc model, fuse 6 amp.

**43990-0062** Service kit (new, -2xxx models only).

*For service and spare parts listing see page 155.*



## PAR 36600

### Fully serviceable, bilge pump.

- 475 usgph (1800 lph) open flow output.
- Self-priming up to 10ft (3m) vertical lift, allows mounting above wet bilges.
- Diaphragm design allows extended dry running.
- Complete with Pumpgard™ strainer.
- Complies with USCG 183.410 and ISO 8846 MARINE (Ignition protection).
- ISO 8849 MARINE (Bilge Pump Standard).

**Fitting:** Connections for 3/4" (19mm) ID hose.

**Size:** 8 5/8" long x 5 7/8" wide x 8 1/4" high (22.4cm x 15cm x 21cm).

**Weight:** 11 lb (5 kg).

**36600-0000** 12 Volt dc model, fuse 15 amp.

**36600-0010** 24 Volt dc model, fuse 8 amp.

**30124-0000** Service kit.

*For service and spare parts listing see page 154.*



Included

## PAR 34600

### Fully serviceable, bilge pump.

- 645 usgph (2450 lph) open flow output.
- Self-priming up to 10ft (3m) vertical lift, allows mounting above wet bilges.
- Diaphragm design allows extended dry running.
- Permanently lubricated ball bearings add to pump life.
- Complies with USCG 183.410 and ISO 8846 MARINE (Ignition protection).
- ISO 8849 MARINE (Bilge Pump Standard).

**Fitting:** Connections for 1" (25mm) ID hose.

**Size:** 9 3/16" long x 8 7/8" wide x 10 1/2" high (23.4cm x 22cm x 26.7cm).

**Weight:** 13 lb (6 kg).

**34600-0000** 12 Volt dc model, fuse 15 amp.

**34600-0010** 24 Volt dc model, fuse 8 amp.

*Requires a Bilge Strainer, see accessories page 65.*

**30101-0000** Service kit.

*For service and spare parts listing see page 154.*

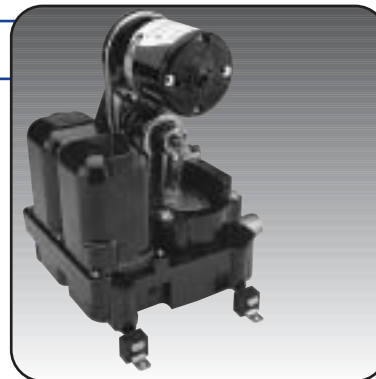

## Bilge Pumpgard™ Strainer

- Strainer protects all electric diaphragm bilge pumps.
- Prevents unnecessary pump breakdowns caused by particles in the water.
- Transparent housing allows instant inspection.
- 46200-0000 model installs in-line between bilge pick up and pump.
- Quick in-place cleaning of the 20 mesh stainless steel screen.

**Fitting:** Connections for 3/4" (19mm) ID hose.

**Weight:** 1/2 lb (0.2 kg).

**Size:** 4 3/4" long x 2 3/4" wide x 2 1/2" high (12cm x 7cm x 6cm).

**46200-0000** Model for 3/4" (19mm) ID hose.

**46200-0010** 3/4" (19mm) ID hose x Plug-in 90 degree

**18753-0020** Replacement 20# mesh filter.



## Bilge Master

**Water resistant Master Panel with 3-way switch and front access fuse holder for any automatically controlled 12 or 24 Volt dc electric (or electromagnetic clutch) bilge pump to 30 amps.**

- Water resistant switch and fuse holder allows mounting in exposed positions.

- Amber light shows that automatic mode is set, whilst red light shows whenever pump runs.

**Size:** 3 7/8" wide x 2 3/8" high (10cm x 6cm).

**Weight:** 1/4lb (0.1kg).

**29140-0000** Illuminated switch panel, for 12 and 24 Volt dc up to 30 amps complete with 5, 10, 20 and 30 amp fuses.

**Not available in USA.**



## High Capacity Bilge Strainers

**Large strainer surface area ensures unrestricted suction for high capacity bilge pumps.**

- Adjustable mounting bracket for different hull shapes.
- Brass body with polypropylene strainer.
- Models for 3/4" (19mm) and 1" (25mm) ID hose.

**Fitting:** Connections for 3/4" (19mm) or 1" (25mm) ID hose

**Size:** 13 1/2" long x 1 3/4" diameter (35cm x 5cm).

**Weight:** 1/2 lb (0.25 kg).

**35890-0000** High Capacity Strainer for 3/4" (19cm) ID hose.

**35890-0010** High Capacity Strainer for 1" (25cm) ID hose.

**Not available in Europe.**

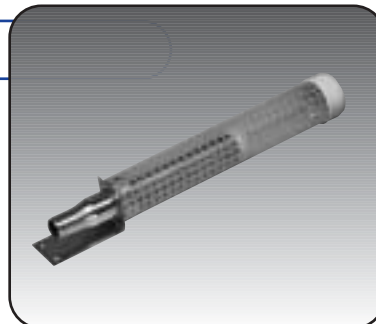

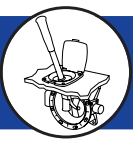

## Water Puppy

### Continuously rated duty bilge/sump pump.

- 380 usgph (1430 lph) output at 3m (10ft) total head.
- Self-priming up to 4ft (1.2m) vertical lift..
- Simple design means fewer wearing parts - all user serviceable.
- Complies with USCG 183.410 and ISO 8846 MARINE (Ignition protection).
- ISO 8849 MARINE (Bilge Pump Standard).

**Fitting:** Connections for 1/2" NPT male threaded fittings, and for 1" (25mm) ID hose.

**Size:** 6 3/8" long x 4 3/4" wide x 3 1/2" high (16.2cm x 12.1cm x 8.9cm).

**Weight:** 6 1/2 lb (3 kg).

**18660-0121** 12 Volt dc model, fuse 15 amp (Non CE).

**6303-0001** Replacement Impeller.

*For service and spare parts listing, see page 149.*



## Commercial Duty Water Puppy

### High flow, continuously rated bilge pump offering good discharge head.

- 470 usgph (1770 lph) output at 10ft (3m) total head.
- Self-priming up to 8ft (2.4m) vertical lift.
- Bilge debris presents no problem to this bronze bodied, flexible impeller design.
- Simple design means fewer wearing parts - all user serviceable.
- Complies with USCG 183.410 and ISO 8846 MARINE (Ignition protection).
- ISO 8849 MARINE (Bilge Pump Standard).

**Fitting:** Connections for 1" (25mm) ID hose, or 1/2" NPT male threads.

Do not use plumbing of less than 3/4" (19 mm) internal diameter.

**Size:** 7 1/8" long x 4 3/4" wide x 3 1/2" high (18.1cm x 12.1cm x 8.9cm).

**Weight:** 8 lb (3.6 kg).

**18670-0123** 12 Volt dc model, fuse 15 amp (Non CE).

**18670-0243** 24 Volt dc model, fuse 10 amp (Non CE).

**23680-4003** 12 Volt dc model, fuse 15 amp.

**23680-4103** 24 Volt dc model, fuse 10 amp.

**6303-0003** Replacement impeller.

*For service and spare parts listing see page 149.*



## Utility Puppy 2000

### Continuous rated Utility Puppy 2000 offers high flow for bilge, deck wash and general purpose use, and ten minutes dry running.

- 500 usgph (1920 lph) output at 10ft (3m) total head.
- Dry running for twenty minutes after initial use.
- Self-priming up to 4ft (1.2m) vertical lift.
- Bilge debris presents no problem to this bronze bodied, flexible impeller design.
- Simple design means fewer wearing parts - all user serviceable.
- Complies with USCG 183.410 and ISO 8846 MARINE (Ignition protection).

- ISO 8849 MARINE (Bilge Pump Standard).

**Fitting:** Connections for 3/4" male threads.

**Size:** 7 1/2" long x 4 3/4" wide x 3 1/2" high (19cm x 12cm x 9cm).

**Weight:** 9.7 lb (3.4 kg).

**23920-2403** 12 Volt dc BSP model, fuse 15 amp.

**23920-2503** 24 Volt dc BSP model, fuse 10 amp.

**23920-9403** 12 Volt dc NPT model, fuse 15 amp.

**23920-9503** 24 Volt dc NPT model, fuse 10 amp.

*For service and spare parts listing see page 149.*



## Utility Puppy 3000

### Continuous rated heavy duty Utility Puppy 3000 offers very high flow for bilge, deck wash and general purpose use, and ten minutes dry running.

- 680 usgph (2580 lph) output at 10ft (3m) total head.
- Dry running for ten minutes after initial use.
- Self-priming up to 8ft (2.4m) vertical lift.
- Mechanical seal for extra long life.
- Bilge debris presents no problem to this bronze bodied, flexible impeller design.
- Simple design means fewer wearing parts - all user serviceable.
- Complies with USCG 183.410 and ISO 8846 MARINE (Ignition protection).

- ISO 8849 MARINE (Bilge Pump Standard).

**Fitting:** Connections for 3/4" male threads.

**Size:** 8 1/2" long x 4 3/4" wide x 3 1/2" high (22cm x 12cm x 9cm).

**Weight:** 8.2 lb (4.0 kg).

**23920-2213** 12 Volt dc BSP model, fuse 15 amp.

**23920-2313** 24 Volt dc BSP model, fuse 10 amp.

**23920-9213** 12 Volt dc NPT model, fuse 25 amp.

**23920-9313** 24 Volt dc NPT model, fuse 15 amp.

*For service and spare parts listing see page 149.*



## Maxi Puppy 3000

**High flow, continuously rated bilge pump offering good discharge head.**

- 660 usgph (2640 lph) output at 3m (10ft) total head.
- Self-priming up to 8ft (2.4m) vertical lift.
- Bilge debris presents no problem to this bronze bodied, flexible impeller design.
- Simple design means fewer wearing parts - all user serviceable.
- ISO 8846 MARINE (Ignition Protected).
- ISO 8849 MARINE (Bilge Pump Standard).

**Fitting:** Connections for 1" (25mm) id hose, or 1/2" BSP male threads. Do not use pipework of less than 19 mm (3/4") internal diameter.

**Size:** 8 1/2" long x 4 3/4" wide x 3 1/2" high (22cm x 12cm x 9cm)

**Weight:** 8lb (3.6kg).

**23610-3003** 12 Volt dc model, fuse 20 amp.

**23610-3103** 24 Volt dc model, fuse 10 amp.

**7273-0003** Replacement impeller.

*For service and spare parts listing see page 149.*



## Junior Puppy

**High discharge head continuously rated bilge pump.**

- 225 usgph (900 lph) output at 10ft (3m) total head.
- Self-priming up to 5ft (1.5m) vertical lift.
- Bilge debris presents no problem to this bronze bodied, flexible impeller design.
- Simple design means fewer wearing parts - all user serviceable.
- ISO 8846 MARINE (Ignition protected).
- ISO 8849 MARINE (Bilge pump standard).

**Fitting:** Connections for 3/8" BSP male threads, or 19mm (3/4") id hose.

**Size:** 7 1/8" long x 4 1/4" wide x 3 1/4" high (18cm x 11cm x 9cm).

**Weight:** 6.6lb (3kg).

**23670-4003** 12 Volt dc model, fuse 15 amp.

**23670-4103** 24 Volt dc model, fuse 10 amp.

**SK400-0023** Service kit, includes 9200-0003 nitrile impeller.

*For service and spare parts listing, see page 149.*



## Mini Puppy

**Compact continuously rated low flow pump.**

- 83 usgph (330 lph) output at 10ft (3m) total head.
- Self Priming up to 5ft (1.5m) vertical lift.
- Small bilge debris presents no problem to this Brass bodied pump.
- Simple design means fewer wearing parts - all user Serviceable.
- ISO 8846 MARINE (Ignition protected)
- ISO 8849 MARINE (Bilge pump standard)

**Fitting:** Connections for 3/8" BSP male threads, or 19mm (3/4") id hose.

**Size:** 6" long x 4 3/4" wide x 3 1/2" high (15cm x 12 cm x 8cm )

**Weight:** 2 lb (0.9 kg)

**23620-4003** 12 Volt dc model, fuse 5amp.

**23620-4103** 24 Volt dc model, fuse 3amp

**SK374-0003** Service Kit, includes 1414-0003 nitrile impeller.

*For service and spare parts listing, see page 149.*







Designed for North American Market

Engine Driven,  
Electric Clutch Pumps

Bilge Pumping Systems -

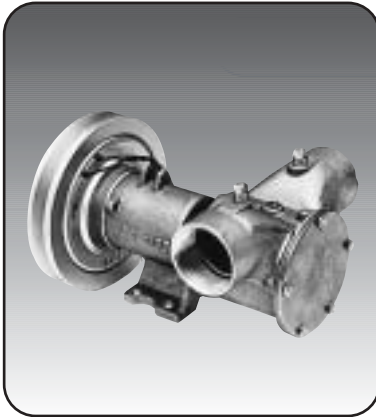

## 18330 Series Electric Clutch Pumps

This manually activated clutch pump offers all the benefits of flexible impeller pumps with a high capacity flow rate and horizontally oriented ports.

- 4710 usgph (18840 lph) at 10ft (3m) total head @ 1750 rpm.
- Self-priming to 15ft (4.5m) vertical lift.
- Mechanical face type shaft seal.
- Nitrile impeller.
- Two pulley options to accommodate either A and B size belts.
- Two single-row shaft ball bearings.

**Fitting:** 2" NPT**Size:** 12-7/16" long x 5-15/16" wide x 5-3/4" high (excluding pulley)  
Pulley Diameter - 7"**Weight:** 24 lb (11 kg)

- 18330-0000** 12 Volt dc Pump with double A groove pulley
- 18330-0040** 12 Volt dc Pump with single B groove pulley
- 18330-0001** 24 Volt dc Pump with double A groove pulley
- 18330-0041** 24 Volt dc Pump with single B groove pulley

For service and spare parts listing see pages 116-140.

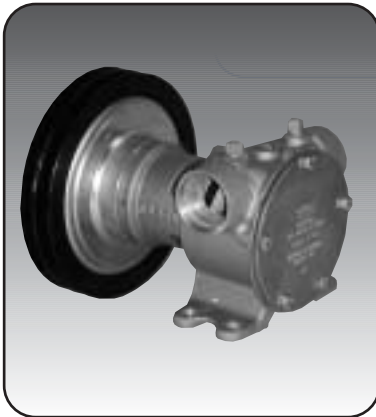

## 11870 Series Electric Clutch Pumps

This electrically activated clutch pump offers all the benefits of flexible impeller pumps with a substantial flow rate and horizontally oriented ports. The electric clutch offers convenient remote activation.

- 3525 usgph (14100 lph) at 10ft (3m) total head @ 1750 rpm.
- Self-priming to 15ft (4.5m) vertical lift.
- Mechanical face type shaft seal.
- Nitrile impeller.
- Two pulley options to accommodate either A and B size belts.
- Double-row ball bearing.

**Fitting:** 1 1/4" NPT**Size:** 8 3/16" long x 5 7/8" wide x 5 1/2" high (excluding pulley)  
Pulley Diameter - 7"**Weight:** 18 lb (8 kg)

- 11870-0005** 12 Volt dc Pump with double A groove pulley
- 11870-0045** 12 Volt dc Pump with single B groove pulley
- 11870-0006** 24 Volt dc Pump with double A groove pulley
- 11870-0046** 24 Volt dc Pump with single B groove pulley
- 11870-0007** 32 Volt dc Pump with double A groove pulley

For service and spare parts listing see pages 116-140.



## 50580 Series Electric Clutch Pumps

Heavy duty bilge and deckwash pump belt driven from the engine, for leisure and commercial craft.

- 1470 usgph (4880 lph) at 10ft (3m) total head @ 1,500 rpm.
- Self Priming up to 15ft (4.5m) vertical lift.
- Bilge debris present no problems to this robust bronze bodied flexible impeller pump.
- Can be remotely controlled from outside the engine room and can be automatically shut off by fitting a vacuum cut off switch.
- Neoprene impeller is fitted as standard.

**Fitting:** 1" NPT**Size:** 6 1/2" long x 5" wide x 7" high  
(160mm x 120mm x 178mm)**Weight:** 11lbs (5kg).

- 50580-9001** 12 Volt dc 2A Pulley E/M Clutch, fuse 5 amp
- 50580-9101** 24 Volt dc 2A Pulley E/M Clutch, fuse 2.5 amp
- 50580-9201** 12 Volt dc 1B Pulley E/M Clutch, fuse 5 amp
- 50580-9301** 24 Volt dc 1B Pulley E/M Clutch, fuse 2.5 amp

For service and spare parts listing see pages 116-140.



Designed for European Market

Engine Driven,  
Electric Clutch Pumps

Bilge Pumping Systems -

## 50270 Series Electric Clutch Pumps

**Very heavy duty bilge and deckwash pump belt driven from the engine, for leisure and commercial craft.**

- 4100 usgph (16350 lph) at 10ft (3m) total head @ 1,500 rpm.
- Self Priming up to 15ft (4.5m) vertical lift.
- Bilge debris present no problems to this robust bronze bodied flexible impeller pump.
- Can be remotely controlled from outside the engine room and can be automatically shut off by fitting a vacuum cut off switch.
- Neoprene impeller is fitted as standard.

**Fitting:** 2" BSP Internal Thread/  
Optional 2" Flange.

**Size:** 10" long x 7" wide x 7" high  
(264mm x 170mm x 178mm).

**Weight:** 27lb (12.2kg)

- 50270-X011** 12 Volt dc 2A Pulley E/M Clutch, fuse 5 amp
- 50270-X111** 24 Volt dc 2A Pulley E/M Clutch, fuse 2.5 amp
- 50270-X211** 12 Volt dc 1B Pulley E/M Clutch, fuse 5 amp
- 50270-X311** 24 Volt dc 1B Pulley E/M Clutch, fuse 2.5 amp

'X' = 0, flanged ports, 'X' = 2, BSP ports

For service and spare parts listing see pages 116-140.

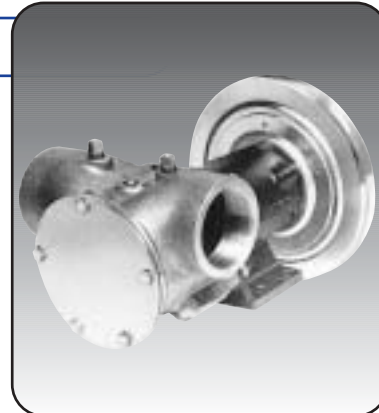

## 50220 Series Electric Clutch Pumps

**Very heavy duty bilge, deckwash, and fire fighting pump belt driven from the engine, for leisure and commercial craft.**

- 2925 usgph (11700 lph) at 10ft (3m) total head @ 1,500 rpm.
- Self Priming up to 15ft (4.5m) vertical lift.
- Bilge debris present no problems to this robust bronze bodied flexible impeller pump.
- Can be remotely controlled from outside the engine room and can be automatically shut off by fitting a vacuum cut off switch.
- Neoprene impeller is fitted as standard.

**Fitting:** 1 1/2" Flange

**Size:** 9 1/2" long x 6" wide x 7" high  
(239mm x 153mm x 178mm)

**Weight:** 25lbs (11.2kg)

- 50220-0011** 12 Volt dc 2A Pulley E/M Clutch, fuse 5 amp
- 50220-0111** 24 Volt dc 2A Pulley E/M Clutch, fuse 2.5 amp
- 50220-0211** 12 Volt dc 1B Pulley E/M Clutch, fuse 5 amp
- 50220-0311** 24 Volt dc 1B Pulley E/M Clutch, fuse 2.5 amp

For service and spare parts listing see pages 116-140.

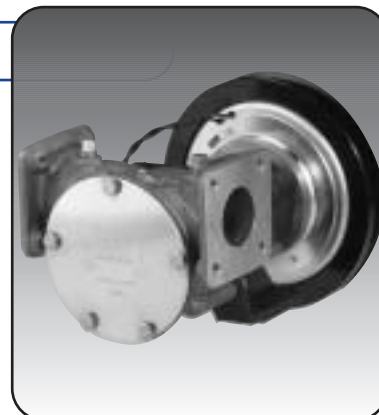

## 50200 Series Electric Clutch Pumps

**Very heavy duty bilge, deckwash, and firefighting pump belt driven from the engine, for leisure and commercial craft.**

- 2925 usgph (11700 lph) at 10ft (3m) total head @ 1,500 rpm.
- Self Priming up to 15ft (4.5m) vertical lift
- Bilge debris present no problems to this robust bronze bodied flexible impeller pump.
- Can be remotely controlled from outside the engine room and can be automatically shut off by fitting a vacuum cut off switch.
- Neoprene impeller is fitted as standard.

**Fitting** 1 1/2" BSP Internal Thread.

**Size:** 9 1/2" long x 6" wide x 7" high  
(239mm x 153mm x 178mm)

**Weight:** 25lbs (11.2kg)

- 50200-2011** 12 Volt dc 2A Pulley E/M Clutch, fuse 5 amp
- 50200-2111** 24 Volt dc 2A Pulley E/M Clutch, fuse 2.5 amp
- 50200-2211** 12 Volt dc 1B Pulley E/M Clutch, fuse 5 amp
- 50200-2311** 24 Volt dc 1B Pulley E/M Clutch, fuse 2.5 amp

For service and spare parts listing see pages 116-140.

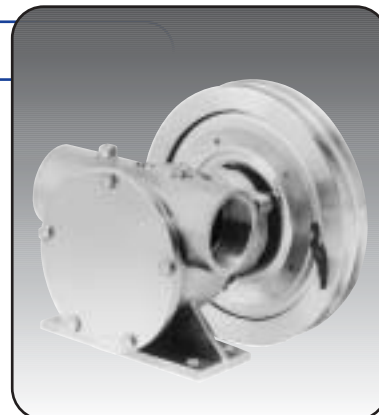

## 50580 Series Electric Clutch Pumps

**Heavy duty bilge and deckwash pump belt driven from the engine, for leisure and commercial craft.**

- 1470 usgph (4880 lph) at 10ft (3m) total head @ 1,500 rpm.
- Self Priming up to 15ft (4.5m) vertical lift.
- Bilge debris present no problems to this robust bronze bodied flexible impeller pump.
- Can be remotely controlled from outside the engine room and can be automatically shut off by fitting a vacuum cut off switch.
- Neoprene impeller is fitted as standard.

**Fitting:** 1" BSP Internal Thread

**Size:** 6 1/2" long x 5" wide x 7" high  
(160mm x 120mm x 178mm)

**Weight:** 11lbs (5kg)

- 50580-2001** 12 Volt dc 2A Pulley E/M Clutch, fuse 5 amp
- 50580-2101** 24 Volt dc 2A Pulley E/M Clutch, fuse 2.5 amp
- 50580-2201** 12 Volt dc 1B Pulley E/M Clutch, fuse 5 amp
- 50580-2301** 24 Volt dc 1B Pulley E/M Clutch, fuse 2.5 amp

For service and spare parts listing see pages 116-140.





Designed for North American Market



## 51270-9013 Manual Clutch Pumps

This manually activated clutch pump offers all the benefits of flexible impeller pumps with a high capacity flow rate and horizontally oriented ports.

- 4100 usgph (16350 lph) at 10ft (3m) total head @ 1500 rpm.
- Self-priming to 15ft (4.5m) vertical lift.
- Mechanical face type shaft seal.
- Nitrile impeller.
- Clutch pulley accommodates both A and B size belts.

- Two single-row shaft ball bearings.

**Fitting:** 2" NPT.

**Size:** 12<sup>7</sup>/<sub>16</sub>" long x 5<sup>15</sup>/<sub>16</sub>" wide (excluding pulley) x 8<sup>7</sup>/<sub>8</sub>" high; Pulley Dia. 7".

**Weight:** 24 lb (11 kg).

**51270-9013** Pump with nitrile impeller, full cam and mechanical seal.

*For service and spare parts listing see pages 116-140.*

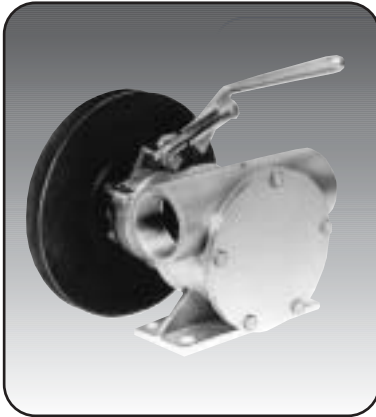

## 51200-9013 Manual Clutch Pumps

This manually activated clutch pump offers all the benefits of flexible impeller pumps with a substantial flow rate.

- 2925 usgph (11700 lph) at 10ft (3m) total head @ 1500 rpm.
- Self-priming to 15ft (4.5m) vertical lift.
- Mechanical face type shaft seal.
- Nitrile impeller.
- Clutch pulley accommodates both A and B size belts.
- Double-row ball bearing.

**Fitting:** 1<sup>1</sup>/<sub>2</sub>" NPT.

**Size:** 9<sup>5</sup>/<sub>8</sub>" long x 5<sup>15</sup>/<sub>16</sub>" wide (excluding pulley) x 8<sup>7</sup>/<sub>8</sub>" high; Pulley Diameter - 7".

**Weight:** 18 lb (8 kg).

**51200-9013** Pump with nitrile impeller, full cam and mechanical seal.

*For service and spare parts listing see pages 116-140.*



## 6590-0005 Manual Clutch Pumps

This manually activated clutch pump offers all the benefits of flexible impeller pumps with a substantial flow rate and horizontally oriented ports.

- 3525 usgph (14100 lph) at 10ft (3m) total head @ 1750 rpm.
- Self-priming to 10ft (3m) vertical lift.
- Nitrile impeller.
- Clutch pulley accommodates a B size belt.
- Double-row ball bearing.

**Fitting:** 1<sup>1</sup>/<sub>4</sub>" NPT

**Size:** 8<sup>1</sup>/<sub>16</sub>" long x 5<sup>1</sup>/<sub>2</sub>" wide (excluding pulley) x 8<sup>7</sup>/<sub>8</sub>" high; Pulley Diameter - 6"

**Weight:** 18 lb (8 kg)

**6590-0005** Pump with nitrile impeller, full cam and mechanical seal.

*For service and spare parts listing see pages 116-140.*



## 51580-9001 Manual Clutch Pumps

This manually activated clutch pump offers all the benefits of flexible impeller pumps with a moderate flow rate and horizontally oriented ports.

- 1470 usgph (4880 lph) at 10ft (3m) total head @ 1500 rpm.
- Self-priming to 15ft (4.5m) vertical lift.
- Mechanical face type shaft seal.
- Neoprene impeller.
- Clutch pulley accommodates both A and B size belts.

- Spaced sealed for life bearings.

**Fitting:** 1" NPT.

**Size:** 7-13<sup>1</sup>/<sub>16</sub>" long x 4-3<sup>4</sup>/<sub>4</sub>" wide (excluding pulley) x 7-9<sup>1</sup>/<sub>16</sub>" high; Pulley Diameter - 6".

**Weight:** 9 lb (4 kg).

**51580-9001** Pump with manual clutch.

*For service and spare parts listing see pages 116-140.*



Designed for European Market

## 51270 Series Manual Clutch Pumps

**Very heavy duty bilge, deckwash, and fire-fighting pump belt driven from the engine, for leisure and commercial craft.**

- 4100 usgph (16350 lph) at 10ft (3m) total head @ 1,500 rpm.
- Self priming up to 15ft (4.5m) vertical lift.
- Bilge debris present no problems to this robust bronze bodied flexible impeller pump.
- Dependable manual control will operate even under the toughest conditions.
- Clutch pulley will accommodate both A and B type pulley belts.

- Easily serviced and maintained.
- Neoprene impeller is fitted as standard.

**Fitting:** 2" BSP Internal Thread/  
Optional 2" Flange

**Size:** 12" long x 7" wide x 9" high  
(316mm x 170mm x 224mm).

**Weight:** 25lbs (11kg).

**51270-0011** Manual Clutch, flanged ports

**51270-2011** Manual Clutch, BSP ports

*For service and spare parts listing see pages 116-140.*

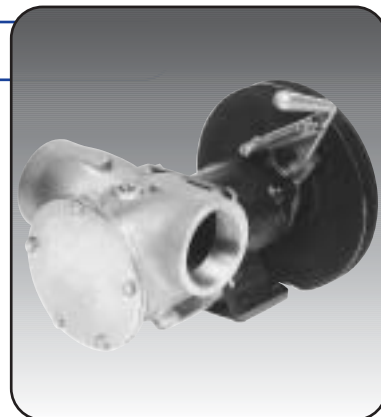

## 51220 Series Manual Clutch Pumps

**Very heavy duty bilge, deckwash, and fire-fighting pump belt driven from the engine, for leisure and commercial craft.**

- 2725 usgph (11700 lph) at 10ft (3ft) total head @ 1,500 rpm.
- Self Priming up to 15ft (4.5m) vertical lift.
- Bilge debris present no problems to this robust bronze bodied flexible impeller pump.
- Dependable manual control will operate even under the toughest conditions.

- Clutch pulley will accommodate both A and B type pulley belts.
- Easily serviced and maintained.
- Neoprene impeller is fitted as standard.

**Fitting:** 1 1/2" Flange

**Size:** 11 1/2" long x 6" wide x 9" high  
(292mm x 152mm x 226mm).

**Weight:** 22lbs (10kg).

**51220-0011** Manual Clutch

*For service and spare parts listing see pages 116-140.*

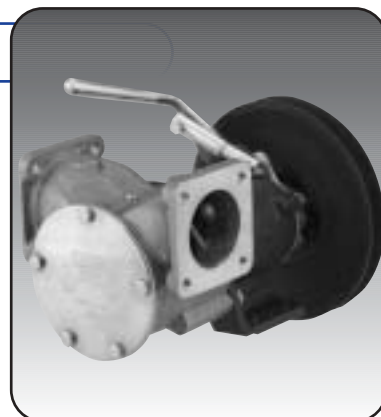

## 51200 Series Manual Clutch Pumps

**Heavy duty bilge and deckwash pump belt driven from the engine, for leisure and commercial craft.**

- 2925 usgph (11700 lph) at 10ft (3m) total head @ 1,500 rpm.
- Self Priming up to 15ft (4.5m) vertical lift.
- Bilge debris present no problems to this robust bronze bodied flexible impeller pump.
- Dependable manual control will operate even under the toughest conditions.
- Clutch pulley will accommodate both A and B type pulley belts.

- Easily serviced and maintained.
- Neoprene impeller is fitted as standard, optional nitrile impeller available.

**Fitting:** 1 1/2" BSP Internal Thread

**Size:** 9 1/2" long x 6" wide x 9" high  
(244mm x 150mm x 226mm).

**Weight:** 18lbs (8kg).

**51200-2011** Manual Clutch

*For service and spare parts listing see pages 116-140.*



## 51580 Series Manual Clutch Pumps

**Heavy duty bilge and deckwash pump belt driven from the engine, for leisure and commercial craft.**

- 1470 usgph (4880 lph) at 10ft (3m) total head @ 1,500 rpm.
- Self Priming up to 15ft (4.5m) vertical lift.
- Bilge debris present no problems to this robust bronze bodied flexible impeller pump.
- Dependable manual control will operate even under the toughest conditions.
- Clutch pulley will accommodate both A and B type pulley belts.

- Easily serviced and maintained.
- Neoprene impeller is fitted as standard.

**Fitting:** 1" BSP Internal Thread

**Size:** 8" long x 5" wide x 7 1/2" high  
(198mm x 120mm x 189mm).

**Weight:** 11lbs (5kg).

**51580-2001** Manual Clutch

*For service and spare parts listing see pages 116-140..*

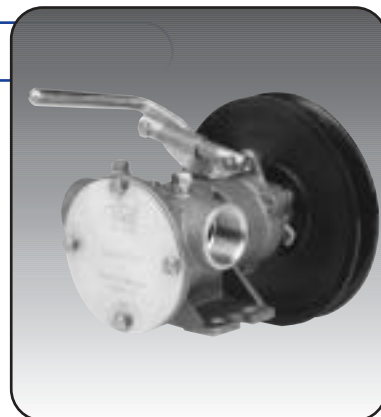

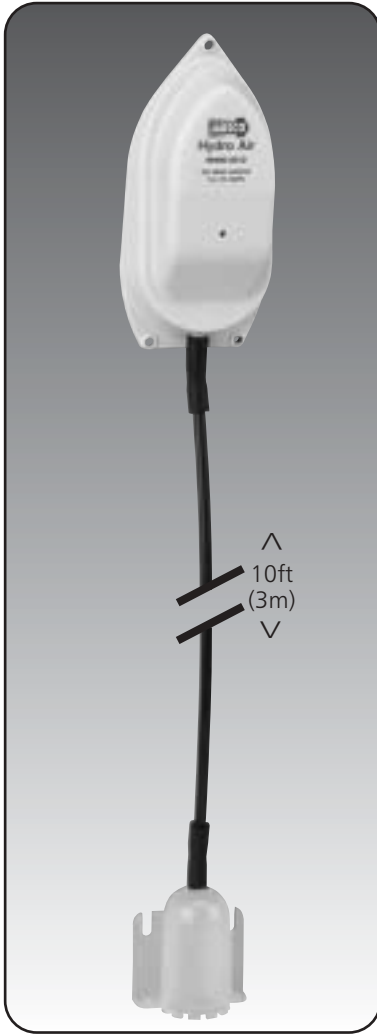

### Hydro Air Switch

Ultra reliable bilge switch, which will automatically operate bilge pumps once water level reaches 2 1/4" (55mm). As water rises in the bell and tube increases, operating a diaphragm switch in the switch unit. All electrical components are clear of the water and no sensitive electronics are used.

- Proven highly reliable design using new moulding techniques.
- Styling compliments modern interiors.
- Automatic operation of bilge pumps or audible and visual high water level alarms.

- Turns on at 2 1/4" (55mm), off at 1" (25mm).
- Diaphragm switch can be mounted up to 10ft (3m) above plastic airbell.

**Size:** Switch - 6" x 1 3/4" x 3" (15.3cm long x 4.5cm high x 7.5cm wide)  
Airbell - 2 3/8" x 1 1/4" x 4" (6cm long x 3cm wide x 10cm high)

**Weight:** Switch - 1/2lb (0.2kg).

**59400-0012** Hydro Air Switch for 12 Volt dc, up to 20 amps.

**59400-0024** Hydro Air Switch for 24 Volt dc, up to 10 amps.

**59407-1000** Replacement air bell.

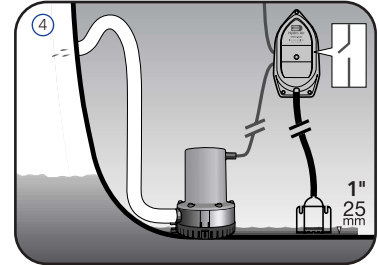
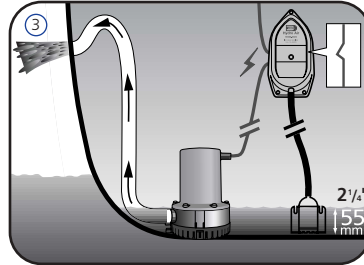
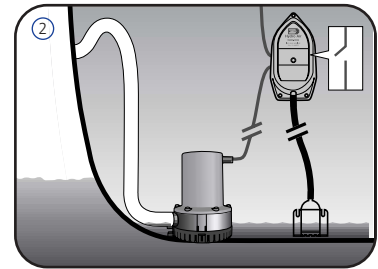
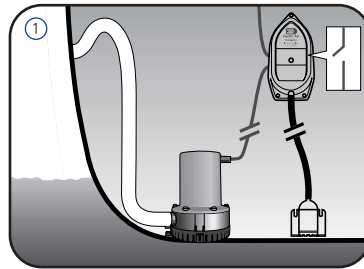

### Bilge Master

Water resistant Master Panel with 3-way switch and front access fuse holder for any automatically controlled 12 or 24 Volt dc electric (or electromagnetic clutch) bilge pump to 30 amps.

- Water resistant switch and fuse holder allows mounting in exposed positions.
- Amber light shows that automatic mode is set, whilst red light shows whenever pump runs.

Not available in USA

**Size:** 3 7/8" wide x 2 3/8" high (10cm x 6cm).

**Weight:** 1/4lb (0.1kg).

**29140-0000** Illuminated switch panel, for 12 and 24 Volt dc up to 30 amps complete with 5, 10, 20 and 30 amp fuses.



## Y-Valve

**Robust Y-Valve for use in bilge applications. Allows two bilge sections to be emptied by one pump.**

- Rotating ports allow routing of hoses onto the valve from almost any direction.
- Can be operated through bulkhead by use of optional handle extension.
- Waste and corrosion resistant construction throughout.
- Can be padlocked.

**Fitting:** Connections for with both 1 1/2" (38mm) ports and extra 1" (25mm) straight inlet port.

**Size:** 7 3/8" long x 7 1/4" wide x 4 5/8" high (20cm x 19cm x 12cm).

**Weight:** 2 lb (0.9 kg).

- 45490-1000** Y-Valve.
- 45500-1000** Handle Extension Kit.
- 45488-0000** Service Kit.
- 45493-0000** Replacement Handle.
- 18753-0661** Replacement Ports Kit.

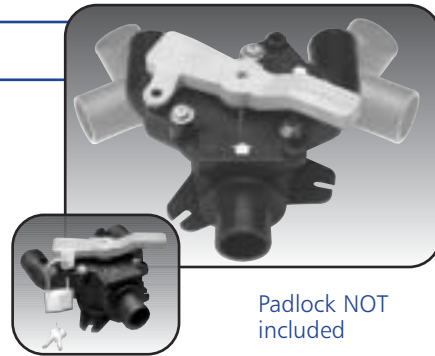

Padlock NOT included

## Bilge Strainers with Non-return Valves

**Stop bilge debris blocking inlet suction hose and reduces the risk of debris entering and blocking the pump.**

- Available to suit 3/4", 1" and 1 1/2" (19mm, 25mm and 38mm) ID hose.
- Non-return valve fitted to stop bilge water draining back when pumping stops.
- Repositional ports allow horizontal, vertical or sideways hose leads.
- Easily removable strainer plate for cleaning.

- Corrosion resistant materials throughout.

**Fitting:** Connections for 3/4", 1" or 1 1/2" (19mm, 25mm or 38mm) ID hose.

**Size:** 6 3/4" long x 2 3/4" wide x 2 1/2" high (17cm x 7.2cm x 6cm).

**Weight:** 1/4 lb (0.1 kg).

- 29290-1020** Bilge Strainer for 3/4" (19mm) ID hose.
- 29290-1000** Bilge Strainer for 1" (25mm) ID hose.
- 29290-1010** Bilge Strainer for 1 1/2" (38mm) ID hose.

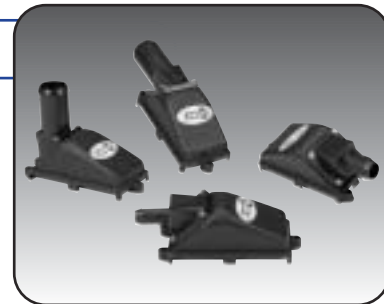

## Vacuum Switch

**Protects any 12 or 24v dc electric, or electromagnetic clutch, bilge pump up to 15 amp from dry running drainage - especially flexible impeller designs.**

- Manual start, automatic stop - remote start possible.
- Vacuum sensor shuts off power to pump motor or clutch when bilges are clear.
- Simply mounts between bilges and pump.
- Some Jabsco pumps have integral mounting point.

**Fitting:** Connection for 1/4" female thread and supplied with 1/4" x close nipple. Suitable for 12 and 24 Volt dc, 220 Volt ac, up to 15 amp, 110 Volt AC up to 10 amp. For remote start, install 15 amp push button next to Master Switch.

**Size:** 4" diameter x 3 1/2" high (11cm x 9cm).

**Weight:** 1 1/2 lb (0.7kg).

**4732-0000** Vacuum Switch.



**WARNING**



Jabsco Vacuum Switch is not ignition protected, do not install where flammable vapors are present.