



Model 7018 Sail Boat Lock Valve

Many sail boat skippers prefer mechanical steering because they can feel the pressure on the rudder when they are sailing and that will, therefore, give them a much better feel of wind and weather conditions.

In order to satisfy the discriminating sailors, Kobelt developed the 7018 remote mounted lock valve. This valve fulfils all the wishes of a sail boat captain.

A regular good hydraulic steering system is equipped with a lock valve behind the hydraulic helm pump. This lock valve prevents any hydraulic pressure feedback going to the steering wheel.

Putting the remote lock valve 7018 in the open position will require the skipper to keep his hand on the wheel to affect a course and the pressure of the rudder can be felt at the steering wheel.

By putting a remote lock valve into the closed position the rudder will remain where it was left without having to hold on to the wheel, the hydraulic oil is locked in the system and will maintain the given direction.

Ordering Information

7018 can be ordered in either B -Black, W - White, C - Chrome or A - Bronze.

* When ordering a pump to go with this unit, it must be ordered with a letter "P" (for porting block) e.g. 7005-ALP and should not be used in conjunction with the regular lock valve option.

Summary

- Closed lock valve for heavy weather or following seas, lighter steering.
- Open lock valve for full feel of rudder.

Approx. Weight: 4.4 lb (2 kg)

MODEL 7018

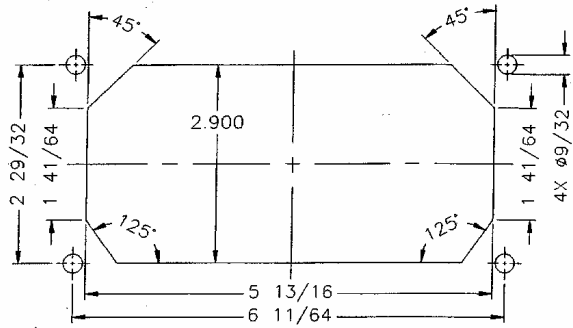
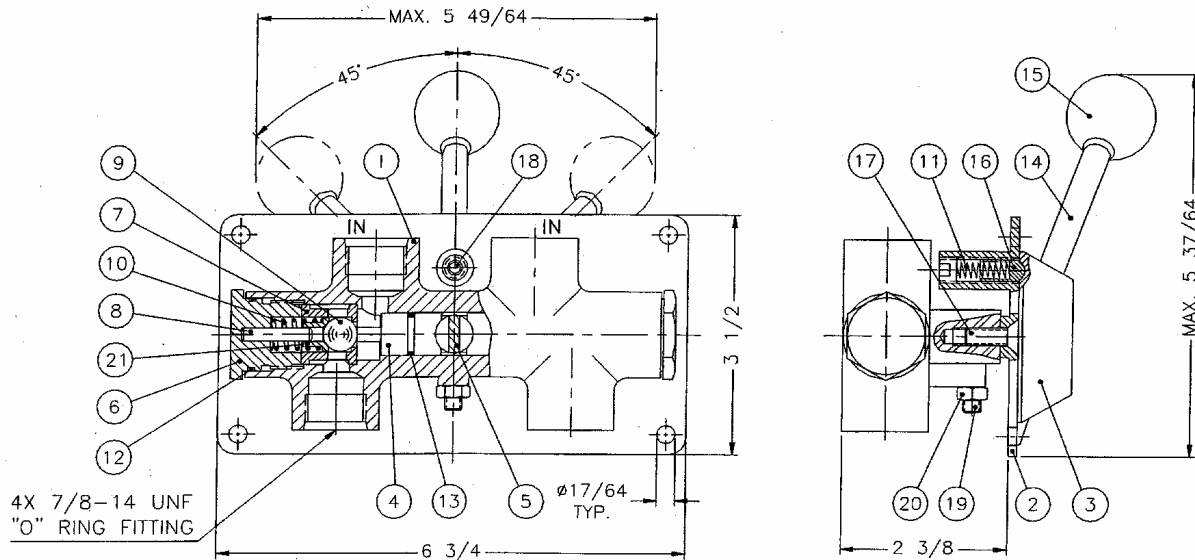

"CUT-OUT" DIMENSIONS

Item	Qty	Part Number	Description	Item	Qty	Part Number	Description
1	1	7018-0001	Lock Valve Body	12	2	1101-0021	"O" Ring
2	1	7018-0002	Plate	13	2	1101-0014	"O" Ring
3	1	7018-0003	Hub	14	1	7169-0010	Lever
4	2	7018-0004	Shuttle	15	1	2030-0011	Knob
5	1	7018-0005	Shaft	16	1	2545-0012	Detent
6	2	7012-0025	End Cap	17	2	1015-1008	Flat Hd Screw
7	2	7012-0026	Ball Seat	18	1	1016-1204	Socket Set Screw
8	2	7018-0024	Pin	19	1	7018-0015	Socket Set Screw
9	2	1301-0116	Ball	20	1	1022-0211	Hex Jam Nut
10	2	1201-0218	Spring	21	2	7012-0031	Spring Seat
11	1	1201-0062	Spring				