



Ruitenwissers

Windscreen wipers

Scheibenwischer

Essuie-glaces

Limpiaparabrisas

Tergicristalli



RW
DIN

Copyright © 2013 Vetus n.v. Schiedam Holland



Waarschuwing
Verdraai **nooit** de schroef aan de buitenzijde van de ruitenswissermotor.

Warning
Never adjust the screw on the outside of the wiper motor.

Achtung
Verdrehen Sie **niemals** die Schraube an der Außenseite des Scheibenwissermotors.

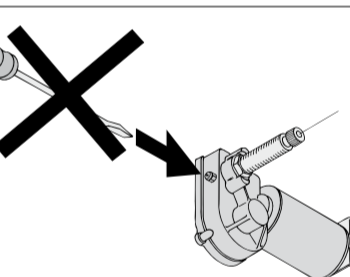

Attention
Ne jamais tordre la vis à l'extérieur du moteur d'essuie-glace.

Precaución
No atornillar/ destornillar jamás el tornillo situado en el exterior del motor del limpiaparabrisas.

Avvertenza
Non girare mai la vite situata all'esterno del motorino del tergicristallo.

Dit produkt voldoet aan de vereisten van EG-richtlijn:
This product complies to the requirements of EC Directive:
Dieses Produkt entspricht der geforderten EG-Richtlinie:
Ce produit est conforme à la directive CE:
Este producto cumple las normas de la Directiva EEC:
Questo prodotto è conforme alla normativa CE:

EN 55 014 - EMC Directive 89/336/EEC
EN 60 335 - 1 (1994)
EN 61 000 - 4 - 2 (1995)



FOKKERSTRAAT 571 - 3125 BD SCHIEDAM - HOLLAND - TEL.: +31 10 4377700
TELEFAX: +31 10 4372673 - 4621286 - E-MAIL: sales@vetus.nl - INTERNET: http://www.vetus.com
Printed in China
110217.01 2013-03

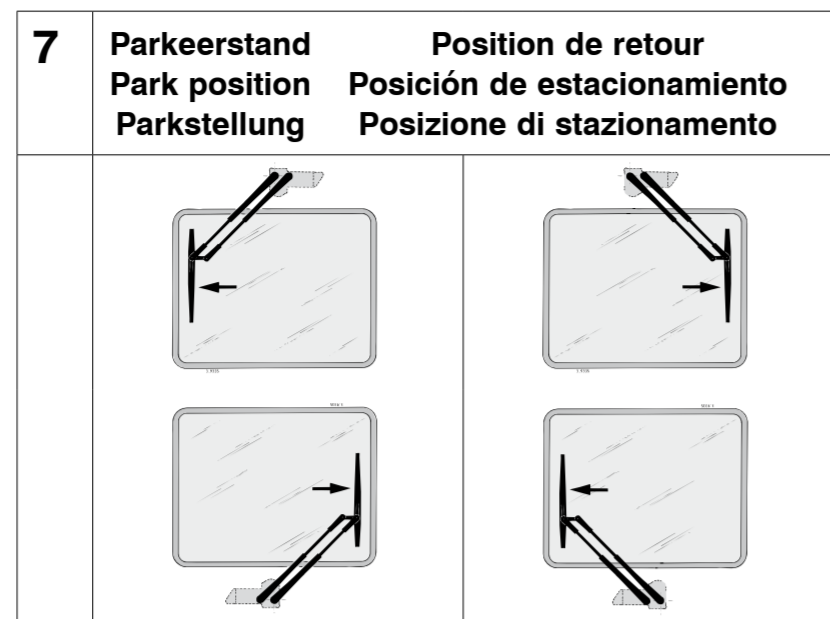
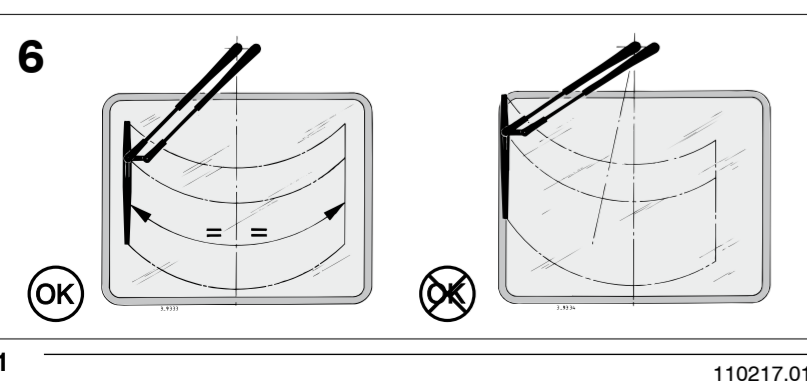
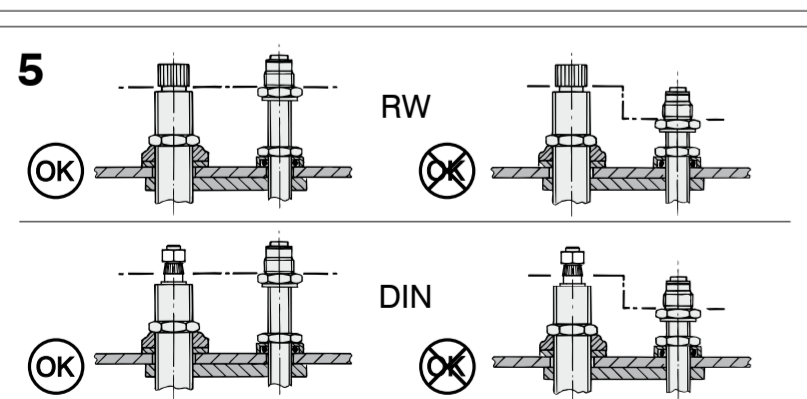
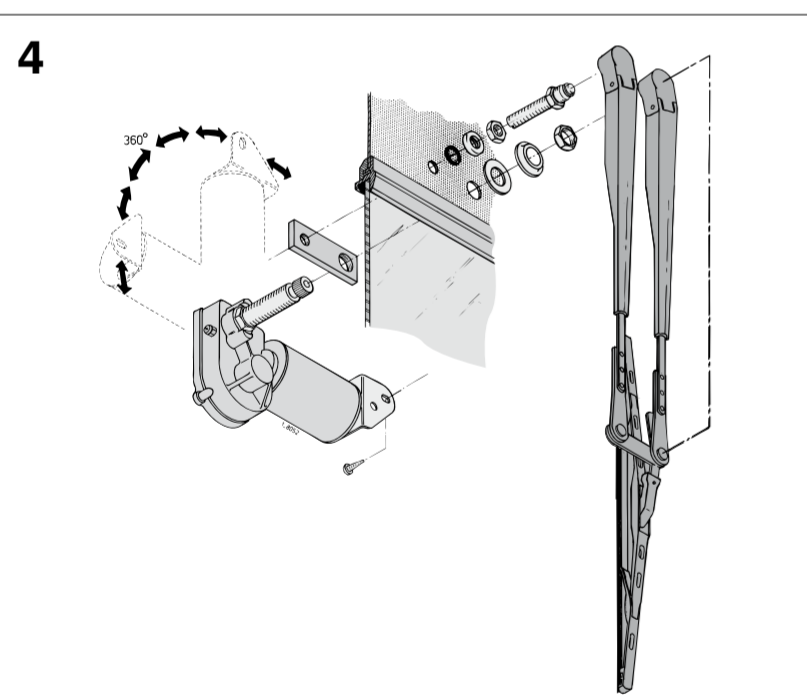
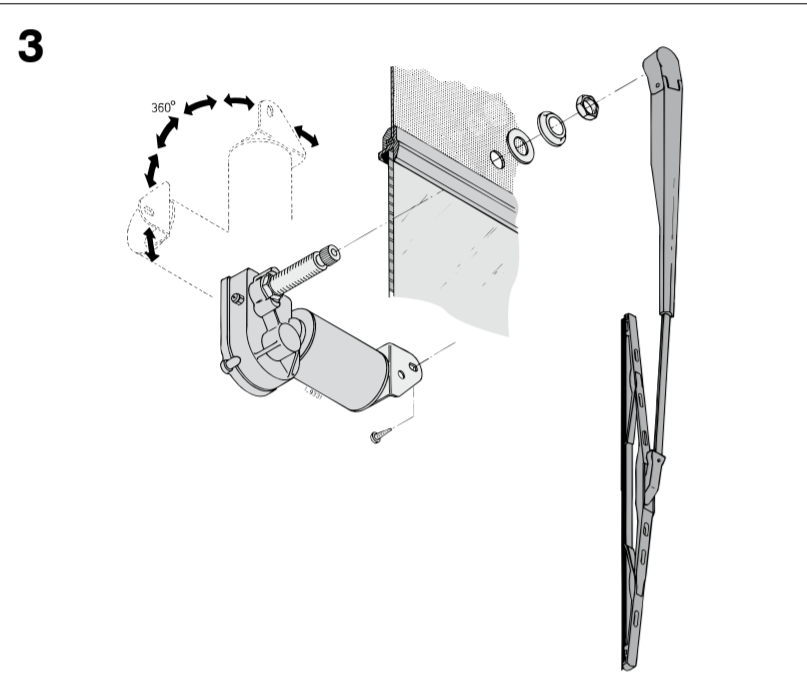
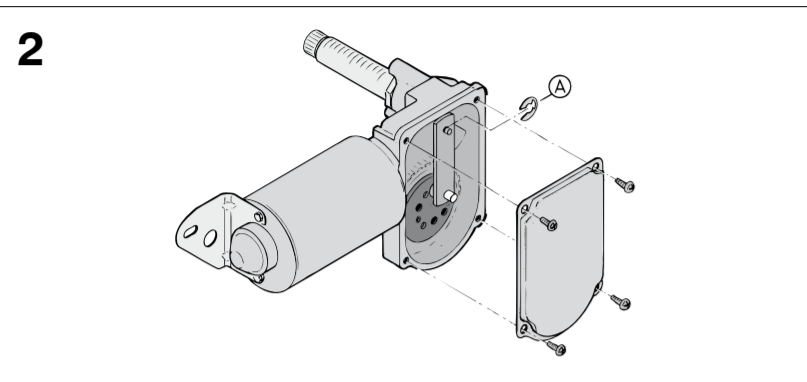
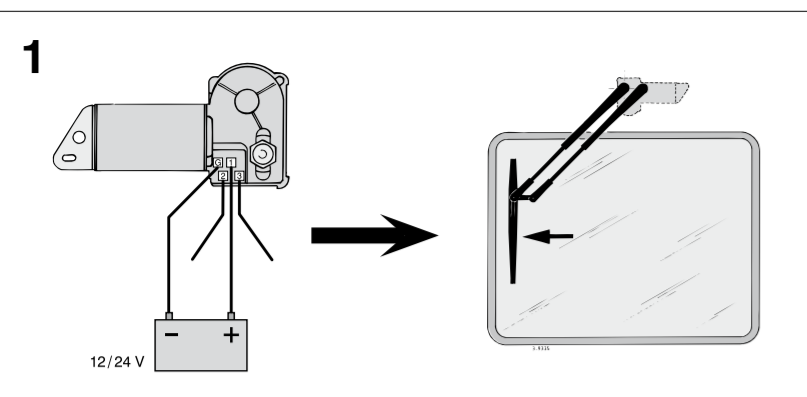

	Parkeerstand Park position Parkstellung Posizione di stazionamento	Position de retour Posición de estacionamiento Posizione di stazionamento
Angolo di pultura		
Ángulo de barrido		
Ángulo d'essuyage		
Wischwinkel		
Wiping angle		
Wishoek		

Aansluitschema **Schéma de raccordement électrique**
Wiring diagram **Esquema de conexión**
Anschlußschema **Schema di collegamento**

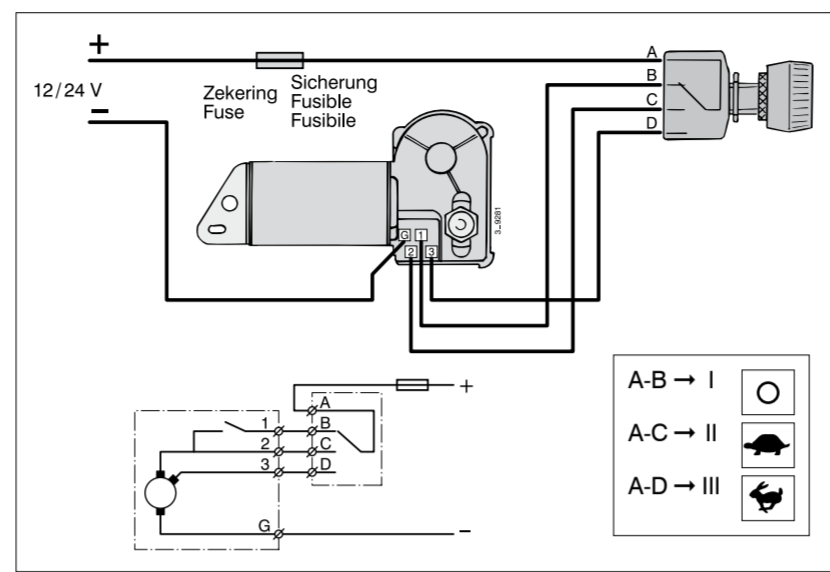

Hoofdafmetingen **Dimensions hors-tout**
Overall dimensions **Dimensiones principales**
Hauptabmessungen **Misure principali**

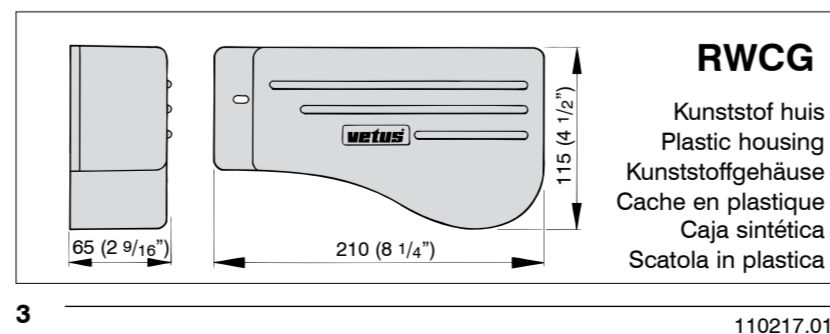
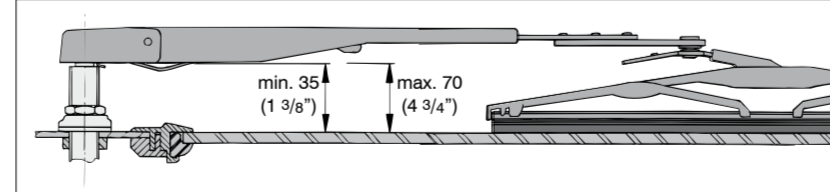
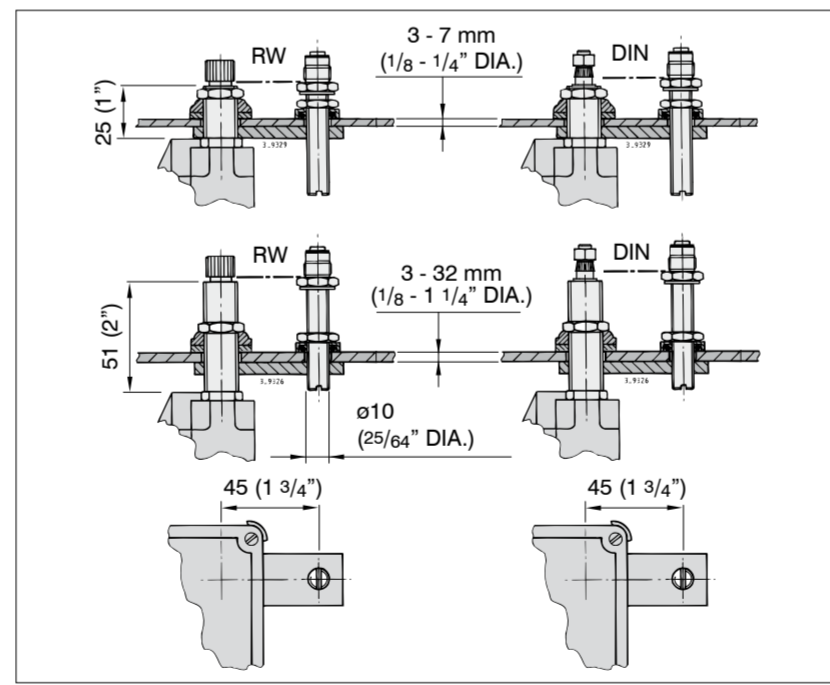
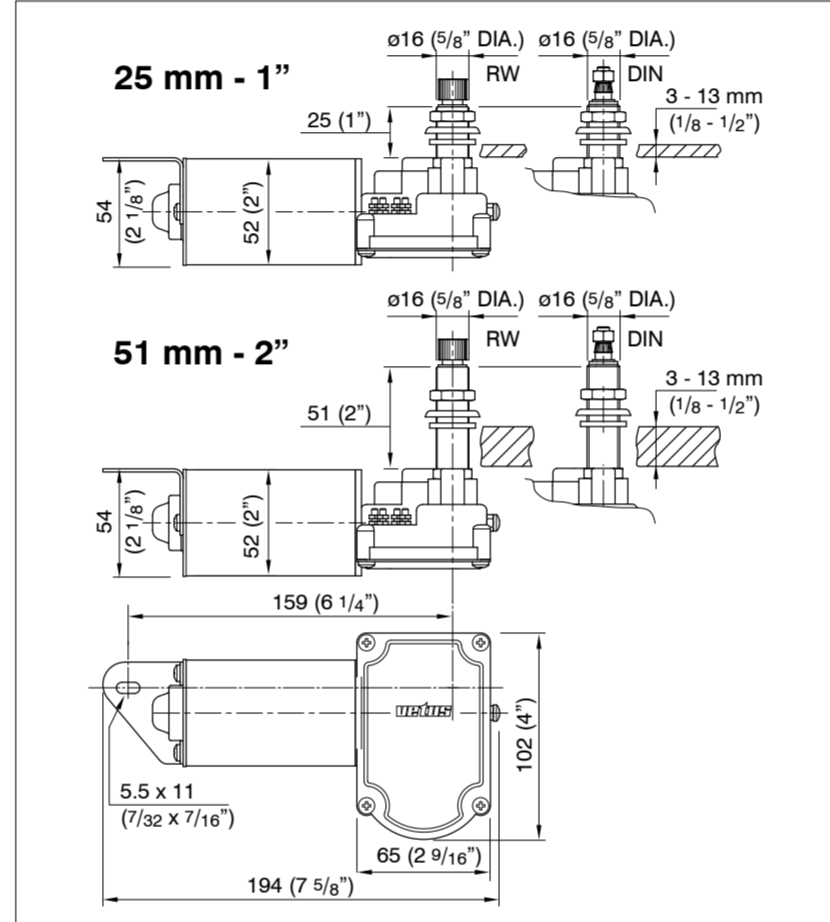

General

Locate mounting position of wiper assembly.

Determine whether adequate space is available for the wiper motor (see 'Overall dimensions').

Also check if it is possible to adjust the selected wiper arm, in combination with the selected blade, for the desired wiping surface (see separate sheet 'Wiping surfaces').

Wiped angle and parked position

The standard setting for the screen wiper gives a wiped angle of 110 degrees and a parked position on the left (when seen from outside with the motor mounted at the top of the screen).
If desired, the angle and/or the parked position may be adjusted.

Before the wiped angle or parked position can be adjusted, the wiper motor should be in the parked position, see Drawing 1.
To check this, connect the negative (-) wire and the '1' wire to the battery. If the motor is not in the parked position, it will turn until it stops in the parked position.
Check that the voltage marked on the wiper motor is the same as the on-board voltage!

Changing the wiped angle or parked position:

- Remove the gearbox cover, see Drawing 2.
- Remove the spindle lock ring from the swinging arm spindle.
- Lift up the connecting strip.

The situation is now as shown in Drawing 7 (110 degrees wiped angle and left-side parked position).

- Remove the two screws (X); the wiper angle plate can now be rotated.
- Determine the new position of the wiper angle plate on the basis of desired wiped angle and parked position with the aid of Drawing 3.
- Replace the screws.
- Replace the connector strip in the gearwheel (in the fitting hole for the angle required).
- Reassemble in reverse order from above.

Mounting wiper motor with single wiper arm, see drawing 3

Use the drill-pattern to mark the holes for stud (16 mm diameter, 5/8") and mounting bracket (for selftapping screw 4.8-mm, no. 10 or for screw M5). Drill the holes.
When the plastic housing is also used, fit the wiper motor in the plastic housing now.
Mount the wiper motor using the supplied washers and nut.
Tighten the nut with a torque of 3.5 - 5.5 Nm (30 - 50 in.lbs.).
Place the wiper arm onto the stud.
Check after the wiring has been connected the position of the wiper arm onto the shaft and the adjusted length of the arm.

Mounting wiper motor with pantograph wiper arm, see drawing 4

Use the drill-pattern for stud (16 mm diameter, 5/8"), for mounting bracket (for selftapping screw 4.8-mm, no. 10 or for screw M5) and for auxiliary stud (10-mm diameter). Drill the holes.
When the plastic housing is also used, fit the wiper motor in the plastic housing now.
Install mounting strip onto the stud. Install wiper motor using the supplied washers and nut.
Tighten the nut with a torque of 3.5 - 5.5 Nm (30 - 50 in.lbs.).
Install auxiliary stud and adjust for the correct height, see drawing 5.
Place the wiper arm onto the stud and mount the auxiliary arm onto the auxiliary stud by means of screwing.
Check after the wiring has been connected the position of the wiper arm onto the shaft and the adjusted length of the both the arms, see drawing 6.

Electrical installation

Make sure that the voltage stamped on the wiper motor is identical as the ship's power supply voltage!
The minimum cross-section for the connecting cables is 1.5 mm² (AWG 16).
Connect wiper motor as per wiring diagram.
A switch* and fuse** or automatic circuit breaker** must be incorporated in the positive cable.

- *) The switch must be rated for 10 A.
- **) Fuse or circuit breaker: 4 A for 12 Volt system
3 A for 24 Volt system

Connect the G connection on the wiper motor to the minus terminal (-) of the ship's power supply. The wiper motor has Insulated return.

Maintenance

When sailing on **sea-water** it is recommended to rinse wiper arm, wiper blade and motor shaft regularly with fresh water.

Technical data

Voltage	: 12 V DC	24 V DC
	Current	Current
Speed 1 (34 sweep/min)	: 1.7 A	0.8 A
Speed 2 (47 sweep/min)	: 2.5 A	1.5 A
(Based on 400 mm (16") long arm and 400 mm (16") long wiper blade)		
Adjustable wiper angle	: 40, 50, 60, 70, 80, 90, 100, 110 degrees.	
Adjustable parking position	: Right or left	
Weight	: 1.2 kg (2 lbs 10 oz)	
Protection	: IP20	

