

OM673L3

For Models: M673L3 and M673LD3

OPERATOR'S MANUAL

Marine Generators | Marine Diesel Engines | Land-Based Generators



NORTHERN LIGHTS





— CALIFORNIA —
Proposition 65 Warning:

Diesel engine exhaust and some of its constituents are known to the State of California to cause cancer, birth defects, and other reproductive harm.

Northern Lights
4420 14th Avenue N.W.
Seattle, WA 98107
Tel: (206) 789-3880
Fax: (206) 782-5455

Copyright ©2015 Northern Lights, Inc.
All rights reserved. Northern Lights™, and
the Northern Lights logo are trademarks of
Northern Lights, Inc.

Printed in U.S.A.
PART NO.: OM673L3 1/15



NORTHERN LIGHTS

OPERATOR'S MANUAL

for Models
M673L3 and M673LD3

*Read this operator's manual thoroughly before starting to operate your equipment.
This manual contains information you will need to run and service your new unit.*

Table of Contents

INTRODUCTION	2	SERVICING (CONTINUED)	
Models Included	2	Fuels - General.....	19
Model Numbers	2	Fuel Filters	19
Serial Numbers	2	Bleeding the Fuel System	20
WARRANTY	3	Injector Service	21-22
SAFETY RULES	3 - 7	Injection Pump.....	21
LOCK OUT / TAG OUT PROCEDURE	8	Cooling System - General.....	21
COMPONENT LOCATIONS		Cooling System Flushing.....	23
M673 Marine Generator	10 - 11	Heat Exchanger	24
PANELS		Raw Water Pump	24
Northern Lights Generator Sets	12	Generator Ends	24
OPERATING PROCEDURES		Electrical System - General	24
Break-in Period.....	13	Glow Plugs.....	25
Before Starting.....	13	Booster Batteries.....	25
Starting.....	13	Battery Care	25
Operating	13	Winterizing / Out-of-Service	25
Stopping.....	13	AC GENERATOR - TF-276D	
Shutdowns and Alarms	14	General.....	26
Spare Parts	14	Connections	27
SERVICING SCHEDULE CHART	15	Operation	28
SERVICING		Maintenance.....	28 - 29
Lubrication - General.....	17	TROUBLESHOOTING	
Checking Oil.....	17	Electrical	30
Oil Changes	17	Engine	31 - 33
Changing Oil Filter	17	DATA SHEET	
Air Filter	18	Marine.....	34
V-Belts	18	WIRING DIAGRAMS	
Valve Clearances.....	18	AC Electrical	35 - 37
		DC Electrical	38 - 41

Proprietary Information

This publication is the property of Northern Lights, Inc.

It may not be reproduced in whole or in part without the written permission of Northern Lights, Inc.

© Northern Lights, Inc. All rights reserved. Litho U.S.A. Publication number OM673L3 1/15

Introduction

Servicing of marine engines and generator sets presents unique problems. In many cases boats cannot be moved to a repair facility. Marine engines cannot be compared to the servicing of automobiles, trucks or even farm equipment. Failures often occur in remote areas far from competent assistance. Marine engines are taxed far more severely than auto or truck engines; therefore, maintenance schedules must be adhered to more strictly.

Failures begin with minor problems that are overlooked and become amplified when not corrected during routine maintenance.

As operator, it is your obligation to learn about your equipment and its proper maintenance. This is not a comprehensive technical service manual. Nor will it make the reader into an expert mechanic. Its aim is to aid you in maintaining your unit properly.

Unit Identification

MODELS INCLUDED

This manual covers the operating instructions for:

M673L3 and M673LD3 marine generator sets.

Model Numbers

Model numbers give the unit's application, block model, aspiration, and RPM:

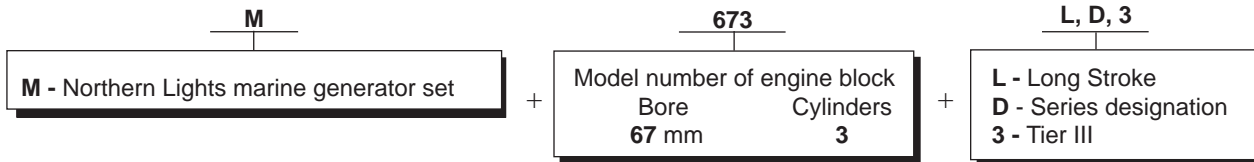

M673L3 = Northern Lights marine diesel generator set with a 673 engine long stroke, TF-276D generator end, Tier III.

M673LD3 = Northern Lights marine diesel generator set with a 673 engine long stroke, TF-276D generator end, Tier III, 5 kW.

Serial Number

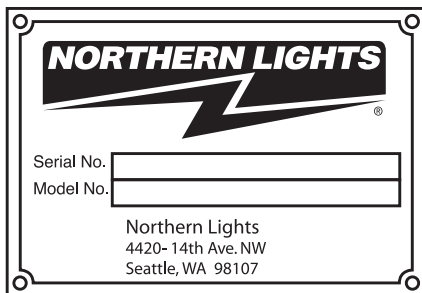

Your set has three serial numbers: ① an engine number stamped on the block, ② a generator plate, and ③ a generator set plate.

Use the serial number on the generator set plate when ordering parts or in correspondence. The generator set plate is found on the service side of the generator and resembles the drawing in Figure 1.

Note, an additional label with the set serial number is placed on the upper front corner of the generator junction box.

Figure 1: Generator set serial number plate.

Warranty

A warranty registration certificate is supplied with your set. It entitles the original purchaser of our equipment to a warranty covering material or assembly faults. The extent of coverage is described in the Limited Warranty Statement. We recommend that you study the statement carefully.

NOTE: If the warranty is to apply, the servicing instructions outlined in this manual must be followed. If further information is needed, please contact an authorized dealer or the factory.

Safety Rules



NOTICE: Accident reports show that careless use of engines causes a high percentage of accidents. You can avoid accidents by observing these safety rules. Study these rules carefully and enforce them on the job.

IMPORTANT SAFETY INSTRUCTIONS.

Electromagnetic equipment, including generator sets and their accessories, can cause bodily harm and life threatening injuries when improperly installed, operated or maintained. To prevent accidents be aware of potential dangers and act safely.

on parts and components from outside suppliers that is not reproduced in this manual. Consult the suppliers for additional safety information.

Learn how to operate the machine and how to use the controls properly. Only trained personnel should operate machines, or work on or around them.



READ AND FOLLOW ALL SAFETY INSTRUCTIONS IN THIS MANUAL, PRIOR TO THE INSTALLATION OF ANY GENERATOR SET OR ACCESSORY. KEEP THESE INSTRUCTIONS FOR FUTURE REFERENCE.

Keep you machine in proper working condition. **UNAUTHORIZED MODIFICATIONS TO THE MACHINERY MAY IMPAIR ITS FUNCTION AND SAFETY PARAMETERS.**

Recognize Safety Symbols and Instructions

In addition to the information found in this section, this operator's manual uses three different signal words to outline potential dangers of a specific nature.

	DANGER	DANGER indicates a hazardous situation which, if not avoided, will result in death or serious injury.
	WARNING	WARNING indicates a hazardous situation which, if not avoided, could result in death or serious injury.
	CAUTION	CAUTION indicates a hazardous situation which, if not avoided, could result in minor or moderate injury.

Prevent Bypass and Accidental Starting

! WARNING

Do not start engine by shorting across start terminal. Engine will start if normal circuitry is bypassed, creating a hazard by runaway machinery.



Start engine only from operator's station.

Follow All Safety Instructions

Carefully read and understand all safety messages in this manual and on your machine's safety signs. Keep signs in good and clean condition. Replace missing or damaged signs. Be sure new equipment components and repair parts include the current safety signs. For replacement signs, proper placement of safety signs or clarification on any safety issue, consult your Northern Lights dealer or the factory. There can be additional safety information contained



Handle Fuel Safely - Avoid Flames

! WARNING

Diesel is highly flammable and should be treated with care at all times. Do not refuel while smoking or when near sparks or open flame.

ALWAYS STOP ENGINE BEFORE FUELING MACHINE. Always fill portable fuel tank outdoors. Never fuel a hot engine.



Safety Rules

Prevent accidental discharge of starting fluids by storing all cans in a cool, safe place, away from sparks or open flame. Store with cap securely on container. Never incinerate or puncture a fuel container.

Prevent fires by keeping machine clean of accumulated trash, grease and debris. Always clean any spilled fuel as swiftly as possible. Do not store oily rags, which can ignite and burn spontaneously.

Be prepared if a fire starts. Keep a first aid kit and fire extinguisher handy. Keep emergency contact numbers for fire department, doctors, ambulance and hospital near the telephone.

Service Machines Safely

! DANGER

Do not wear a necktie, scarf, necklace, rings or other jewelry, or any loose clothing when working near moving parts. Tie long hair behind your head. If any of these items get caught in moving machinery, severe injury or death could result.

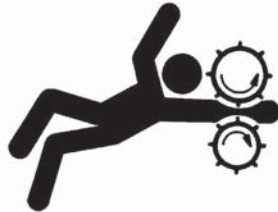

Check for any loose electrical connections or faulty wiring.

Look completely around engine to make sure that everything is clear before starting.

Wear Protective Clothing

! WARNING

To prevent catching anything in moving machinery, always wear close fitting clothes and safety equipment appropriate to the job.

Prolonged exposure to loud noise can cause hearing loss or impairment.

Wear suitable authorized hearing protection, such as earmuffs or plugs to protect against loud noises



Operating equipment requires the full attention of the operator. Do not use radio or music headphones while operating machinery.

Practice Safe Maintenance

! CAUTION

Understand all service procedures before starting work. Keep area clean and dry. Never lubricate, service, or adjust machine while it is in operation.



Keep hands, feet and clothing away from power-driven equipment. When shutting down an engine, disengage all power and operator controls. Allow the engine to cool completely before beginning any service work.

Securely support any machinery elements that must be raised for service work with support or lifting machinery specifically intended for that purpose.

Keep all parts in good conditions and properly installed. Fix damage immediately. Replace any worn or broken parts. Remove any build up of grease, oil or debris.

Disconnect battery ground cable (-) before making any adjustments or service work.

Stay Clear of Rotating Drivelines

! DANGER

Entanglement in rotating drivelines can cause serious injury or death. Keep shields in place at all times. Make sure that rotating shields turn freely in pace with the drivelines.

Do not wear loose fitting equipment around rotating drivelines. Stop the engine and make sure that all moving parts have stopped before making any adjustments, connections, or performing any other type of service to the engine or other driven equipment.



Safety Rules (Continued)

Install all Safety Guards

WARNING

Direct contact with rotating fans, belts, pulley and drives can cause serious injury.

Keep all guards in place at all times during engine operation.

Wear close-fitting clothes. Stop the engine and be sure all fans, belts, pulleys and drives are stopped before making adjustments, connections, or cleaning near fans and their components.

Do not allow anything on your person to dangle into or come in contact with a moving fan, belt, pulley or drive. Fans can act as vacuums and pull materials up from below, so avoid that area as well while in service.



Safe Battery Handling

WARNING

Prevent Battery Explosions

Battery gas is highly flammable. Battery explosions can cause severe injury or death. To help prevent battery explosions, keep sparks, lighted matches and open flame away from the top of battery. When checking battery electrolyte level, use a flashlight.

Never check battery charge by contacting the posts with a metal object. Use a volt-meter or hydrometer.

Frozen batteries may explode if charged. Never charge a battery that has not been allowed to warm to at least 16°C (60°F).

Always remove grounded (-) battery clamp first and replace ground clamp last.

Sulfuric acid in battery electrolyte is poisonous and strong enough to burn skin, eat holes into clothing and other materials, and cause blindness if splashed into eyes.



To Avoid Hazards:

- Fill batteries only in well-ventilated areas.
- Wear appropriate eye protection and rubber gloves.
- Never use air pressure to clean batteries.
- Wear appropriate ventilation equipment to avoid inhaling fumes when adding electrolyte.
- Do not spill or drip electrolyte.
- Use correct jump-start procedure if required.

If acid is spilled on skin or in eyes:

1. Flush skin with water.
2. Apply baking soda or lime to help neutralize acid.
3. Flush eyes with water for 15-30 minutes.
4. Get medical attention immediately.

If acid is swallowed:

1. DO NOT induce vomiting.
2. Drink large amounts of water or milk, without exceeding 2 liters (2 quarts)
3. Get medical attention immediately



WARNING

Battery posts, terminals, and related accessories can contain lead and lead compounds, chemicals known to the State of California to cause cancer and reproductive harm. Wash hands after handling.

Handle Chemical Products Safely

WARNING

Direct exposure to hazardous chemicals can cause serious injury. Among the potentially hazardous chemicals that may be used with Northern Lights products are lubricants, coolants, paints and adhesives.



All potentially hazardous chemicals come with a Material Data Safety Sheet (MSDS). The MSDS provides specific details on chemical products, including physical hazards, safety procedures and emergency response techniques

Safety Rules (Continued)

Read and understand the MSDS for each chemical before you start any job that includes it. Follow the procedures and use appropriate equipment exactly as recommended.

Contact your Northern Lights dealer or Northern Lights factory for MSDS's used on Northern Lights products.

Work in Well Ventilated Areas

! CAUTION

Exhaust fumes from engines contain carbon monoxide and can cause sickness or death. Work in well ventilated areas to avoid prolonged exposure to engine fumes. If it is necessary to run an engine in an enclosed area, route the exhaust fumes out of the area with an approved, leak proof exhaust pipe extension.

Remove Paint Before Welding or Heating

! WARNING

Hazardous fumes can be generated when paint is heated by welding, soldering or using a torch. To avoid potentially toxic fumes and dust, remove paint before heating.



- Remove paint a minimum of 100 mm (4 in.) from the area that will be affected by heat.
- If paint cannot be removed, wear an approved respirator.
- If you sand or grind paint, use an approved respirator.
- If you use solvent or paint stripper, remove stripper with soap and water before welding. Remove solvent or paint stripper containers from the area.
- Allow at least 15 minutes for fumes to disperse before welding or heating.

Do not use a chlorinated solvent in an area where welding will occur. Work only in areas that are well ventilated. Dispose of paint and solvent properly.

Service Cooling System Safely

! WARNING

Opening a pressurized cooling system can release explosive fluids and causing serious burns. Before opening any pressurized cooling system, make sure the



engine has been shut off. Do not remove a filler cap unless it is cool enough to comfortably grip with bare hands. Slowly loosen cap to relieve pressure before opening fully.

Avoid High Pressure Fluids

! WARNING

Relieve pressure prior to disconnecting pressurized lines. Escaping fluid under pressure can penetrate the skin causing serious injury. Always relieve pressure before disconnecting hydraulic or other pressurized lines. Tighten all connections firmly before re-applying pressure.



If searching for leaks, use a piece of cardboard. Always protect your hands and other body parts from high-pressure fluids.

If an accident occurs, see a doctor immediately. Any high pressure spray injected into the skin must be removed within a few hours to prevent the risk of gangrene or other infection.

Avoid Heating Near Pressurized Fluid Lines

! WARNING

Flammable spray can be generated by heating near pressurized fluid lines, resulting in severe burns and bodily injury. Pressurized lines can rupture when heat goes beyond the immediate flame area. Do not weld, solder or use a torch or open flame near pressurized lines or other flammable fluids.



Do Not Open High-Pressure Fuel System

! DANGER

Many Northern Lights engines use high-pressure fuel injection. High-pressure fluid remaining in fuel lines can cause serious injury. Do not disconnect or attempt any repair of fuel lines, sensors, or other

Safety Rules (Continued)

components between the high-pressure fuel pump and nozzles on engines with high pressure fuel systems.



ONLY AUTHORIZED TECHNICIANS CAN PERFORM REPAIRS ON AN HIGH PRESSURE FUEL INJECTION SYSTEMS.

Avoid Hot Exhaust



Avoid exposure to and physical contact with hot exhaust gases. Exhaust parts and streams can reach high temperatures during operation, leading to burns or other serious injury.



Cleaning exhaust filters can also lead to exposure to hot exhaust gas and the injury risk associated with it. Avoid exposure to and physical contact with hot exhaust gases when cleaning exhaust filters.

During auto or manual/stationary exhaust filter cleaning operations, the engine will run at elevated temperatures for an extended period of time. Exhaust parts and streams can reach high temperatures during operation, leading to burns or other serious injury.

Avoid Harmful Asbestos Dust



Inhaling asbestos fibers may cause lung cancer. Avoid breathing any dust that may be generated when handling components containing asbestos fibers, including some gaskets.



The asbestos used in these components is usually found in a resin or otherwise sealed. Normal handling of these components is not dangerous, as long as airborne dust containing asbestos is not generated.

Avoid creating dust. Never use compressed air for cleaning. Avoid brushing or grinding materials containing asbestos. When servicing, wear an approved respirator. A special vacuum cleaner is recommended to clean asbestos. If this vacuum is not available, apply a mist of oil or water on the

material containing asbestos. Keep all bystanders away from any area where asbestos dust may be generated.

Use Proper Lifting Equipment and Techniques



Lifting heavy components incorrectly can cause severe injury or damage to machinery. Avoid unbalanced loads. Do not use lifting eyes. Lift the generator set using lifting bars inserted through the lifting holes on the skid. Follow all recommended removal and installation procedures in this and associated Northern Lights manuals.



Use Proper Tools



Makeshift tools and procedures can create safety hazards. Always use appropriate tools for the job.



Use power tools only to loosen threaded parts and fasteners. For loosening and tightening hardware, always use the correct sized tools.

Do not use US measurement tools on metric fasteners, or vice versa. Use only service parts that meet Northern Lights specifications.

Dispose of Waste Properly



Disposing of waste improperly can threaten the environment and lead to unsafe working conditions. Potentially harmful waste used in Northern Lights equipment can include oil, fuel, coolant, filters and batteries.

Use leakproof containers to drain fluid. Do not use food or beverage containers that may mislead someone into drinking from them.

Do not pour waste onto the ground, down a drain or into any water source.

Lock Out / Tag Out Procedures

Scope

During maintenance, repairs or retooling of a Northern Lights generator set, simply turning the machine off or unplugging it while it is being worked on does not give enough protection to others who are not performing the maintenance or repair. Many serious accidents happen when someone thought the machine was turned off, or all of its energy was safely blocked or released.

General Policy

⚠ CAUTION

To avoid dangerous or hazardous situations, refrain from any of the following:

- Removing or bypassing a guard or other safety device
- Placing any part of your body in a position where you could be caught by moving machinery.
- Cleaning or oiling machinery when in operation.
- Adjusting circuits, chillers, pumps, air handlers, valves, circuit breakers or fans while in operation.
- Working on piping or high pressure systems.

Lock Out/Tag Out Instructions - Electrical Equipment

⚠ WARNING

Be sure the equipment's ON/OFF switch is in the OFF position and is unplugged from any electrical source before attempting to perform any type of work on the equipment. Obtain an electrical plug cap cover with a lockset. Secure the plug terminal end using the electrical plug lockout cap. Lock the cap and retain the key.

If the equipment is directly wired into an electrical box with a shut off switch, obtain a lock pad and/or the appropriate colored tags and place the lock and tag through the shut off lever. Retain the key until the repair is completed and the machine is safe to start. Be certain the shut off lever is in the OFF position before restarting. NEVER give a lock out key to unauthorized personnel.

If the equipment is directly wired into an electrical box without a shut off switch and lock out capability, then a circuit breaker lock out will be required. Obtain a circuit lock and tag set. Install the lock onto the circuit breaker box. Ensure the unit ON/OFF switch is in the OFF position before restarting.

Lock Out/Tag Out Instructions - Pneumatic and Hydraulic Equipment

⚠ WARNING

For servicing pneumatic and hydraulic equipment, the following additional procedures must be implemented, following completion of lock out/tag out procedures for the unit to be serviced:

Shut off air, water or supply valves at the equipment to be serviced.

Check the local bleed-off point for completed release of pressurized air, water or oil.

If shutting off of air, water or other material cannot be achieved at the local supply valve, shut off valves further back in the system and re-check the bleed-off point until complete shut-off is achieved.

Affix a DO NOT OPERATE tag to each valve handle that requires shut off. Each DO NOT OPERATE tag must be signed and dated by the authorized technician servicing the equipment.

Lock Out/Tag Out Instructions - Air Hose Connected Pneumatic Equipment

⚠ WARNING

Equipment connected to the compressed air system through an air hose with a detachable fitting must be shutdown and unplugged. Excess air must be bled prior to removing the air hose, prior to any maintenance or repair activities.

Affix a DO NOT OPERATE tag to the air hose near the detachable fitting. Each DO NOT OPERATE tag must be signed and dated by the authorized technician servicing the equipment. Check that the equipment cannot be operated by activating the ON switch.

Stored Energy

⚠ WARNING

Immediately after applying Lock Out or Tag Out devices, ensure that all potentially hazardous stored or residual energy is relieved, disconnected, restrained and otherwise rendered safe.

Verification of Isolation

⚠ CAUTION

Verify the machinery or equipment is actually isolated and de-energized prior to beginning work on a machine or on equipment that has been locked out.

Restarting Procedures

⚠ CAUTION

Follow the procedures below prior to restoring energy:

- Ensure that all machinery or equipment is properly reassembled. Inspect the machinery or equipment to verify non-essential items have been removed.
- Ensure that all personnel are safely outside danger zones. Notify personnel that lock out/tag out devices have been removed and energy will be reapplied.
- Only authorized personnel may remove lock out/tag out devices or notices.

Notes

Marine Generator Component Locations

Figure 2: M673L3 Non-Service Side, with 2009 base frame

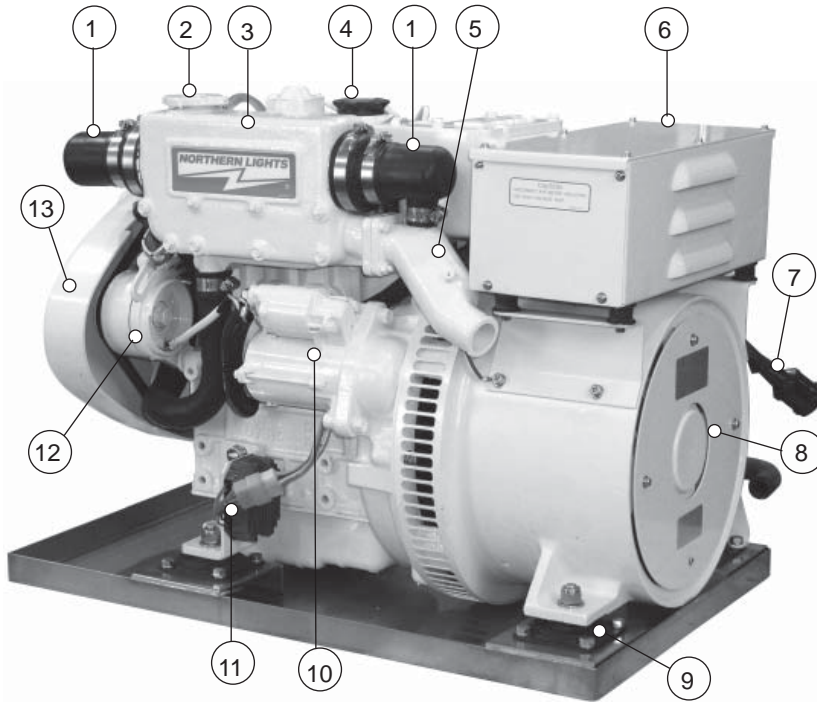
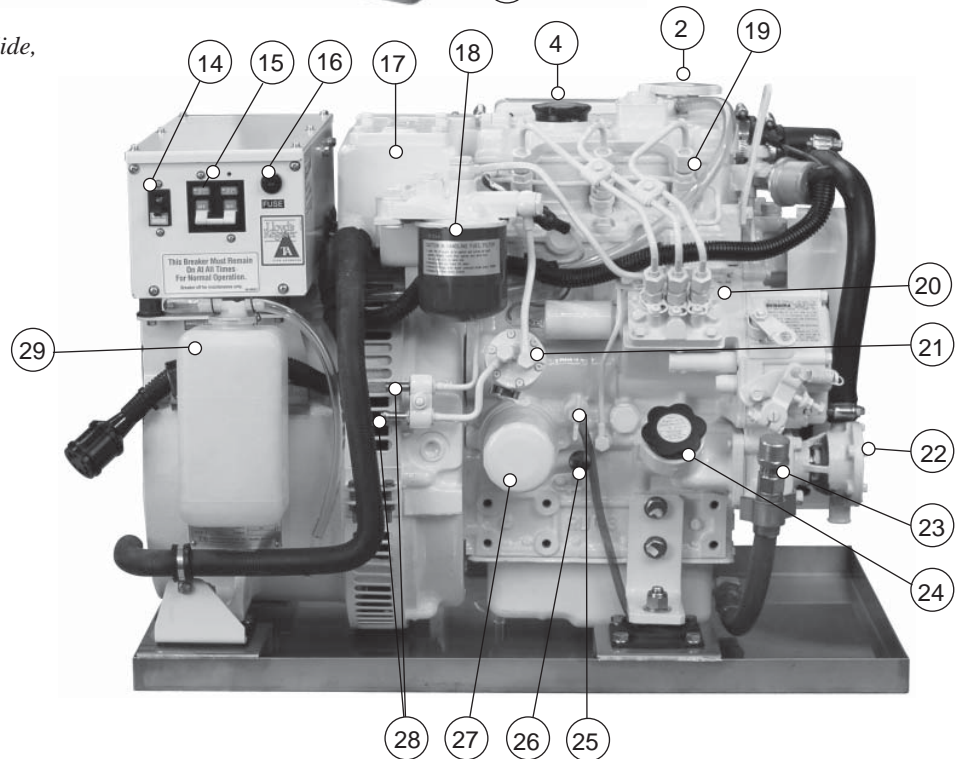

Figure 3: M673L3 Service Side, with 2009 base frame



- | | | | |
|---|-------------------------|---------------------------|---------------------------|
| 1. Heat Exchanger End Cap | 8. Generator End Cover | 16. DC Circuit Breaker | 23. Lube Oil Drain |
| 2. Coolant Fill/Pressure Cap | 9. Vibration Mount | 17. Air Filter Housing | 24. Lube Oil Fill- Side |
| 3. Heat Exchanger/Expansion Tank/Exhaust Manifold | 10. Starter Motor | 18. Secondary Fuel Filter | 25. Block Drain |
| 4. Lube Oil Fill- Top | 11. DC Regulator | 19. Fuel Injector | 26. Lube Oil Dipstick |
| 5. Wet Exhaust Elbow | 12. DC Alternator | 20. Fuel Injection Pump | 27. Lube Oil Filter |
| 6. Generator Junction Box | 13. Belt Guard | 21. Fuel Lift Pump | 28. Fuel Inlet and Return |
| 7. Control Panel Plug-In | 14. AVR Circuit Breaker | 22. Sea Water Pump | 29. Coolant Recovery Tank |
| | 15. AC Circuit Breaker | | |

Marine Generator Component Locations

Figure 2: M673L3 Non-Service Side, with 2010 or later baseframe.

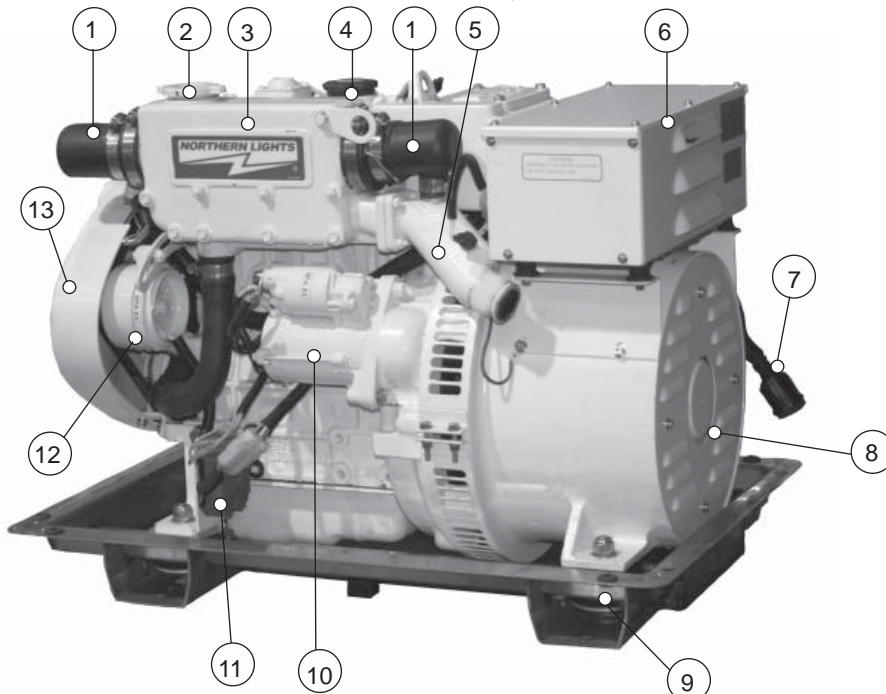
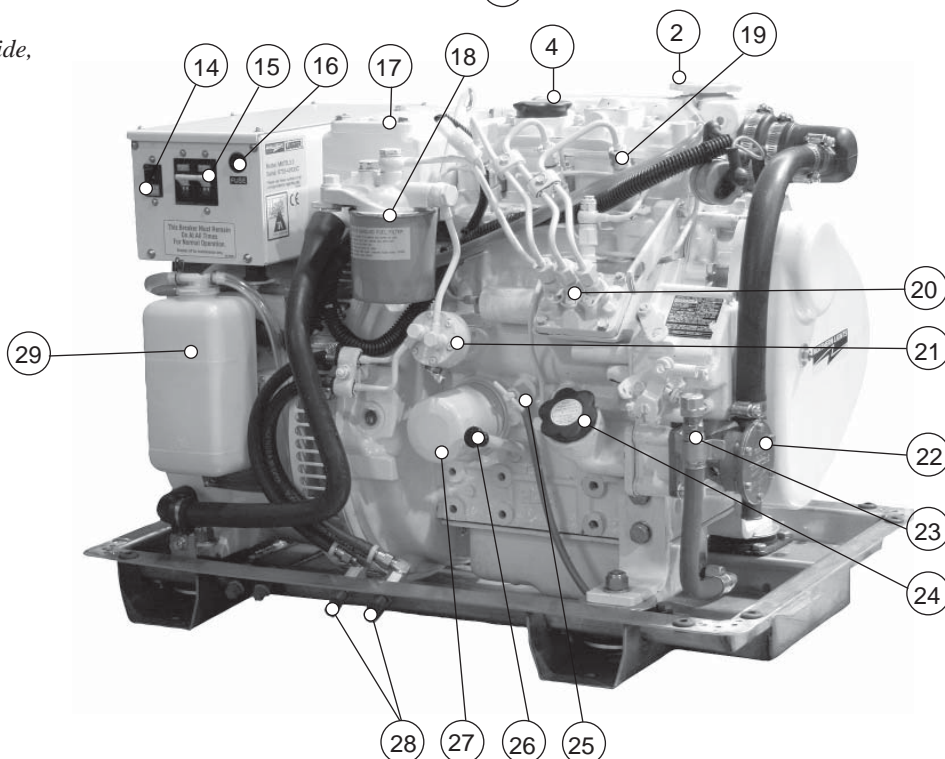

Figure 3: M673L3 Service Side, with 2010 or later baseframe.



- | | | | |
|---|-------------------------|-------------------------|---------------------------|
| 1. Heat Exchanger End Cap | 8. Generator End Cover | 16. DC Circuit Breaker | 23. Lube Oil Drain |
| 2. Coolant Fill/Pressure Cap | 9. Vibration Mount | 17. Air Filter Housing | 24. Lube Oil Fill- Side |
| 3. Heat Exchanger/Expansion Tank/Exhaust Manifold | 10. Starter Motor | 18. Fuel Filter | 25. Block Drain |
| 4. Lube Oil Fill- Top | 11. DC Regulator | 19. Fuel Injector | 26. Lube Oil Dipstick |
| 5. Wet Exhaust Elbow | 12. DC Alternator | 20. Fuel Injection Pump | 27. Lube Oil Filter |
| 6. Generator Junction Box | 13. Belt Guard | 21. Fuel Lift Pump | 28. Fuel Inlet and Return |
| 7. Control Panel Plug-In | 14. AVR Circuit Breaker | 22. Sea Water Pump | 29. Coolant Recovery Tank |
| | 15. AC Circuit Breaker | | |

Control Panels

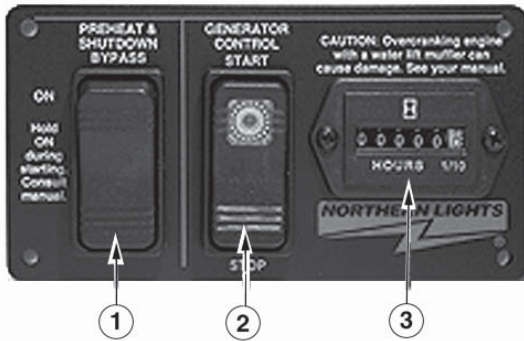

Figure 4: Series 1-B Generator Control Panel

1. SHUTDOWN BYPASS-PREHEAT SWITCH

This switch serves two functions:

1. Preheats glowplugs before beginning the starting process. Press switch for 10-20 seconds before attempting start-up.
2. Bypasses the safety shutdown feature during the starting process. Keep switch engaged while starting engine, and for 2 to 3 seconds afterwards, allowing oil pressure to build beyond shutdown setpoint.

2. ENGINE CONTROL SWITCH

To start the engine, hold this switch in the START position until the engine is running.

NOTE: Excessive cranking of marine sets equipped with water lift muffler systems can cause engine damage. See page 7.

After the engine starts, release the switch and it will return to RUN position. To stop the engine, press the switch to the STOP position.

NOTE: The rocker switch is used on Series 1 panels only, and has a light that glows when the set is running.

3. HOUR METER

Keeps track of engine running time.

4. OIL PRESSURE GAUGE

Shows the oil pressure in the engine lubricating system.

5. WATER TEMPERATURE GAUGE

Registers the temperature of the cooling water.

6. D.C. VOLTMETER

When the engine is running, the voltmeter indicates the voltage output of the alternator.

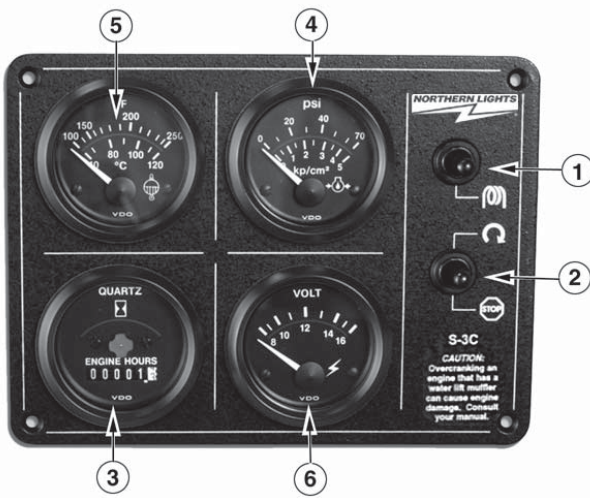

Figure 5: Series 3 Generator Control Panel

For Series 4 Control Panels Only:

7. A.C. VOLTMETER

Shows the generator output voltage.

8. FREQUENCY METER (Hertz)

The frequency meter indicates engine speed: 1800 RPM (60 Hz), or 1500 RPM (50 Hz).

9. AMMETER SELECTOR SWITCH

Used to check each phase for load condition.

NOTE: Always leave this switch in the ON position while the unit is running.

10. A.C. AMMETER

Shows the generator load on each phase. The phase is selected with the Ammeter Selector switch (Item 9).

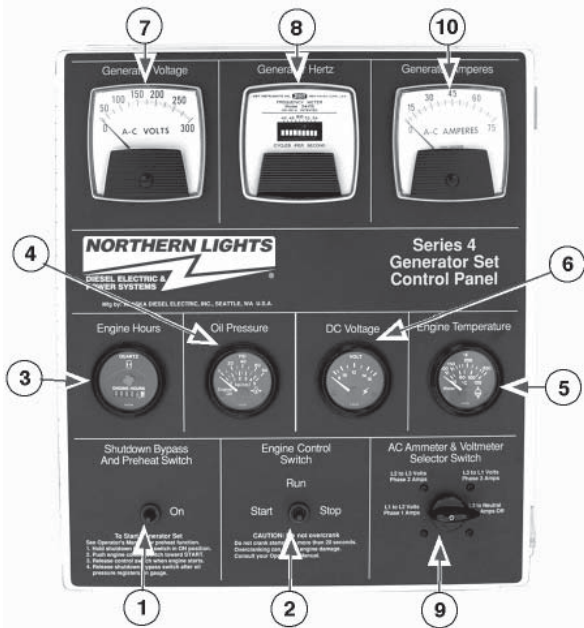

Figure 6: Series 4 Generator Control Panel

Operating Procedures

BREAK-IN PERIOD

1. The first 100 hours on a new or reconditioned engine are critical to its life and performance.
2. Operate the engine under various conditions, particularly heavy loads with minimal idling, to help seat engine components properly.
3. Constantly check the engine temperature and oil pressure gauges (sets with Series 3 or 4 panels).
4. Oil consumption is greater during break-in as piston rings take time to seat.
5. Break-In Oil Changes: Change engine oil and filter at 50 hours. Change oil and filter again at 100 hours, then at every 250 hours (consult Lubricants section for oil recommendation).

BEFORE STARTING

1. Check the water level by removing the pressure cap from the expansion tank or radiator. In order to give the cooling water an opportunity to expand, the level should be about 1 in. (2.5 cm) below the filler cap sealing surface when the engine is cold. If using an overflow bottle, the manifold should be full to the cap and the bottle should have coolant in it.

CAUTION: Use protective clothing and open the filler cap carefully when the engine is warm to prevent burns.



2. Check the oil level in the crankcase with the dipstick. The oil level must be in the waffled area on the stick. Never allow the level to go below this area. Always add the same viscosity of oil as is already in the crankcase.
3. Check the fuel tank level and open any fuel valves.
4. Close the sea-cock, check and clean the sea strainer and reopen the sea-cock.
5. Place the battery switch in the ON position.

NOTE: The battery switch must always be kept ON while the engine is running. If the switch is turned OFF while the engine is running, the battery charging regulator could be ruined.

STARTING

1. Hold the Shutdown Bypass-Preheat switch in the ON position for 10 to 20 seconds before starting a cold engine. Holding the switch too long can burn out the glow plugs.
2. While holding the Shutdown Bypass-Preheat switch in the ON position, push the Engine Control switch to the START position.
3. As soon as the engine starts, release the start switch. Then hold the bypass for 2-3 more seconds. Do not crank the starter for more than 10 seconds consecutively. If the engine fails to start with the first attempt, be sure that it has stopped completely before re-engaging.

NOTE: Excessive cranking of the starter on Marine sets equipped with a water lift muffler can cause engine damage. If the engine does not start after three 10-second cranks, remove the impeller from the raw water pump. This will prevent the muffler from filling with water and backfilling the exhaust line and engine. Once the engine starts, shut it off immediately and re-install the impeller. Re-start the engine and check the exhaust overboard outlet for gushes of water.

OPERATING

1. Units with Series 3 and Series 4 Control Panels: check gauges often. Oil pressure must be above 15 PSI. The D.C. voltmeter should read between 11 and 15 volts at 80°F (25°C) ambient temperature. The coolant temperature gauge must be between 167°F and 194°F (75°C to 90°C). Check the A.C. voltage and frequency meters (Series 4 panel). If the gauges deviate from normal levels, shut down the generator set and investigate.
2. Let the unit run unloaded for a 3 - 5 minute warm-up period.
3. Add electrical load.

STOPPING

1. Remove electrical load from the generator set.
2. Run the engine for a 3 to 5 minute cool down period.
3. Move the Engine Control switch to the STOP position momentarily.
4. Shut off the seacock, fuel valve, and battery switch.

Operating Procedures

SHUTDOWNS AND ALARMS

1. Generator sets have shutdown systems to stop the engine in the event of high water temperature or low oil pressure.
 - a. Other alarms and shutdowns are available as optional equipment.

NOTE: Do not rely on your warning to the exclusion of careful gauge monitoring. Watching your gauges can prevent damage to the unit and dangerous power losses.

2. Do the following when your warning or shutdown system is activated:
 - a. Engage the preheat switch to check the temperature gauge.
 - b. If above 205°F (96°C), use the Trouble Shooting Guide on page 25 to isolate the cause of the overheat.



CAUTION: Do not remove the water fill cap of an overheated engine. Escaping high temperature steam can cause severe burns. Allow the engine to cool and then remove the cap slowly using protective clothing.

- c. Make repairs. Restart your generator set after the temperature gauge registers below 200°F (94°C).
 - d. Watch the temperature gauge regularly and turn off the unit if the temperature rises above 205°F (96°C). Repeat troubleshooting.
3. If shutdown is activated and the temperature gauge shows temperature within normal temperature range:
 - a. This shutdown could have happened because of a too high exhaust temperature. This could have been caused by a damaged impeller or a partially blocked sea water strainer. Check the sea water strainer first. If it is clear, then check the condition of the sea water impeller.
 - b. Check the engine crankcase oil level.
 - c. If the oil level is low, fill with recommended lubricating oil and restart. Watch the oil pressure gauge carefully and shut off the engine if it does not show a normal reading (20-60 PSI) after a few seconds of operation.
 - d. If the oil level is normal, DO NOT restart the engine. Call your dealer for assistance.

SPARE PARTS

1. Northern Lights recommends that you keep the following spare parts on hand for field service. The parts are available from your local Northern Lights dealer. Some marine models already have “On-Board-Kits,” a handy box that contains the most common parts you will need.
2. All owners should have the following:
 - a. Primary and secondary fuel filter elements
 - b. Oil filters
 - c. Air filter
 - d. Alternator belt
 - e. Thermostat and gaskets
 - f. Raw water pump impeller & gaskets
 - g. Glow plug
 - h. Injector and washer
3. If your set is operating a long distance from a servicing dealer, add the following:
 - a. Complete set of injectors
 - b. Copper washers for injector change
 - c. Complete set of glow plugs
 - d. Fuel lift pump

Servicing Schedule Chart

The Servicing Schedule Chart below shows the service schedule required for proper maintenance of your generator set. More detailed coverage of each Service Point (SP) is listed on the page noted in the 'page' column.

DAILY:

- SP1 Check oil level in engine
- SP5 Check V-belt tension
- SP7 Check primary fuel filter
- SP13 Check cooling water level
Check sea strainer
- SP17 Check electrolyte in batteries

AFTER FIRST 50 HOURS:

- SP2/3 Change engine oil and filter
- SP6 Adjust valves

AFTER FIRST 100 HOURS:

- SP2/3 Change engine oil and filter

EVERY 200 HOURS:

- SP2/3 Change engine oil and filter

EVERY 250 HOURS:

- SP4 Check air cleaner
- SP10 Bleed the fuel system
- SP18 Check state of charge of batteries

EVERY 500 HOURS:

- SP8 Change primary fuel filter element
- SP9 Change secondary fuel filter
- SP21 Inspect condition of exhaust elbow

EVERY 1000 HOURS:

- SP4 Change air cleaner element
- SP6 Check valve clearances
- SP11 Check injectors
- SP16 Change impeller in raw water pump

EVERY 2500 HOURS:

- SP12 Check fuel injection pump
- SP14 Check and flush cooling system
- SP15 Check and clean heat exchanger

SERVICE POINT	PAGE	OPERATION	DAILY	50 Hours	200 Hours	250 Hours	500 Hours	1000 Hours	2500 Hours
		ENGINE:							
SP1	11	Check oil level	•						
SP2	11	Change engine oil 1) 5)		•	•				
SP3	11	Change lube oil filters 1) 5)		•	•				
SP4	12	Check air cleaner, change element @ 1000 hrs. 1) 4)				•			
SP5	12	Check V-belt tension 1) 4)	•						
SP6	12	Check valve clearances 1) 2)						•	
		FUEL SYSTEM:							
SP7	13	Check primary filter (Racor) 2) 3)	•						
SP8	13	Change primary filter element (Racor) 2) 3)					•		
SP9	13	Change secondary fuel filter 1) 3)					•		
SP10	14	Bleed the fuel system 3)							
SP11	15-16	Check injectors 1) 3) 6)						•	
SP12	16	Check fuel injection pump 7)							•
		COOLING SYSTEM:							
SP13	16	Check cooling water level	•						
SP14	17	Check and flush cooling system							•
SP15	17	Check and clean heat exchanger							•
SP16	17	Change impeller in raw water pump 1) 3)						•	
SP21		Inspect condition of exhaust elbow 1) 4)					•		
		ELECTRICAL SYSTEM:							
SP17	18	Check electrolyte level in batteries 1) 4)		•					
SP18	18	Check condition of batteries with hydrometer 1) 4)						•	
		OUT OF SERVICE:							
SP20	18	Winterizing or out-of-service 3)							

- 1) Perform all maintenance once a year even if hour level has not been reached.
- 2) Consult manufacturer's maintenance schedule, note on chart.
- 3) Whenever necessary.
- 4) More often if necessary.
- 5) After first 50 hours, then at 100 hours, then every 200 hours.

- 6) Clean injection nozzles every 1500 hours.
- 7) For EPA emission standards fuel nozzle needs to be cleaned every 1500 hours, the fuel nozzle and fuel pump need to be cleaned, adjusted, or repaired every 3000 hours, and the quality guarantee for these parts is 1500 hours or 2 years.

Service Record Notes

Servicing

LUBRICATION - GENERAL

1. Use only clean, high quality lubricants stored in clean containers in a protected area.
2. These lubricants are acceptable:
 - a. API Service CC/CD/CE single viscosity oils.
 - b. API Service CC/CD/SF multi-viscosity oils.
3. Use the proper weight oil for your average operation temperature.

Air Temperature	Single Viscosity	Multi-Viscosity
Above 32°F (0°C)	SAE 30W	SAE 15-40W
-10 to 32°F (-23 to 0°C)	SAE 10W	SAE 10-30W
Below -10°F (-23°C)	SAE 5W	SAE 5-20W

Figure 9: Lube Oils

4. Some increase in oil consumption may be expected when SAE 5W and SAE 5-20W oils are used. Check oil level frequently.
5. Never put additives or flushing oil in crankcase.

SP1. CHECKING OIL LEVEL

1. Check the oil level in the crankcase with the dipstick. The oil level must be in the waffled area on the stick. Never allow the level to go below this area. Follow the lubrication recommendations above.

SP2. OIL CHANGES

1. The set is delivered with special break-in oil. Change the engine oil and oil filter after 50 hours of operation. Use Service CC 30 weight oil during the first 100 hours.
2. Change the oil and filter again at 100 hours using the oil recommended in Figure 9. After this, change oil and filter every 200 hours.
3. During intermittent cold weather operation, change oil every 100 hours or six weeks, whichever comes first.
4. Change oil at any seasonal change in temperature when a new viscosity of oil is required.
5. Change oil when engine is warm.
6. Dispose of waste oil in an approved manner.
7. Never use a flushing oil.
8. Loosen the clamp on the oil change tube. Remove cap. Drain oil. Replace the cap and tube.
9. Refill engine with recommended oil.
10. Engine capacity with new oil filter is:

M673L3 & LD3 – 3.3 quarts (3.1 liters)

SP3. CHANGING LUBE OIL FILTER

1. Change the lube oil filter every with every oil change.
2. Use a filter wrench to remove old filter. Dispose of filter in approved manner.
3. Make sure the gasket from the old filter is removed and discarded. Clean mount face.
4. Spread a thin film of engine oil on the rubber gasket on the new filter and screw it on nipple until gasket meets the sealing surface.
5. Using hands only – no wrench – tighten filter one-half turn farther. Overtightening can do damage to filter housing.
6. Fill engine with recommended oil. Start engine and check for leakage. Stop engine, wait 3 minutes, and check oil level. Add additional oil if necessary.
7. Oil filter part numbers are:

M673L3 & LD3 – #24-08001

Servicing

SP4. AIR CLEANER

1. Inspect air cleaner every 250 hours. In dusty conditions check more often.
2. Inspect the element. If it is dirty, wash the element in soapy water. Rinse and dry thoroughly before re-installing. Replace if necessary. Part number is: **M673L3 & LD3 - #24-28003**

NOTE: Make absolutely sure no impurities enter the engine while changing the element. Do NOT run the engine with the air cleaner removed.

SP5. V-BELTS

1. Check the tension and wear on the V-belt daily.
2. Use your thumb to press on the belt at the midpoint between the crankshaft and alternator pulleys. The tension is correct if the belt can be depressed about 3/16 in. (5 mm).

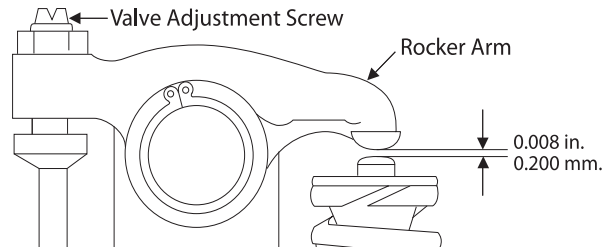

Figure 10: Valve Adjustment

SP6. VALVE CLEARANCES

1. Adjust valve clearance every 1000 hours.
2. Valve adjustments should be done if the cylinder head bolts have been re-tightened. Engine should be cold and NOT running.
3. To bring the No. 1 cylinder to top dead center in the compression stroke, align the timing mark; the top mark of the crank pulley with that of the timing gear case. Remove the rocker arm cover and turn the crankshaft forward and backward. If the inlet and exhaust valves of the No. 1 cylinder do not move it is in top dead center position. When the valves move, or rock, turn the crankshaft one full turn and align the top mark of the crank pulley with the top mark of the timing gear case.
4. Loosen the lock nut and adjust the clearance between the rocker arm and valve guide of both the intake and exhaust valves with the adjustment screw (Figure 10). Clearance on both intake and exhaust valves should be 0.008 in. (0.2 mm).
5. Repeat steps 3 and 4 for each cylinder. Each set of valves must be adjusted individually.
6. Replace the rocker arm cover. Tighten cover nuts to 5 - 8 ft/lbs (0.8 - 2.3 kg/m).

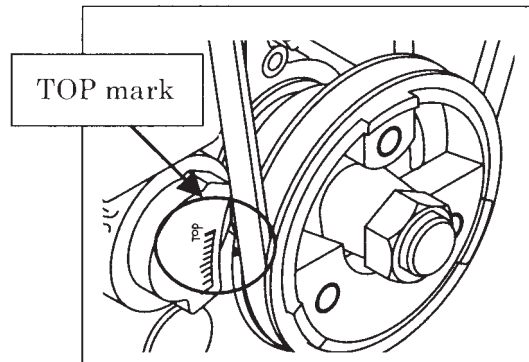

Figure 11: Timing Mark

Cylinder No.	1		2		3	
Valve Arrangement	Int.	Exh.	Int.	Exh.	Int.	Exh.
When No.1 cylinder is at Top Dead Center in the compression stroke	○	○		○		
With the crankshaft turned 360° in normal direction from above			○		○	○

Valve Arrangement

Servicing

FUELS - GENERAL

1. Use only clean, high quality fuels of the following specifications, as defined by ASTM designation D975 for diesel fuels:
 - a. Use Grade No. 2 diesel at ambient temperatures above freezing 32°F (0°C).
 - b. Use Grade No. 1 at ambient temperatures below freezing and for all temperatures at an altitude of above 5,500 ft. (1500 meters).
2. Use fuel having less than 1% sulphur (preferably less than 0.5%).
3. The cetane number should be a minimum of 45.
4. DO NOT use these unsuitable grades of fuel:
 - a. Domestic heating oils, all types.
 - b. Class B engine.
 - c. Class D domestic fuels.
 - d. Class E, F, G or H industrial or marine fuels.
 - e. ASTM-D975-60T No. 4-D and higher number fuels.
5. Storing fuel:
 - a. Keep dirt, scale, water, and other foreign matter out of fuel.
 - b. Avoid storing fuel for long periods of time.
 - c. Fill the fuel tank at the end of each day's operation. This will reduce condensation.

SP7-9. FUEL FILTERS

1. Your generator set should have a primary fuel filter installed. We recommend the Racor brand of fuel filter-water separators.
 - a. Check the primary fuel filter daily as recommended by the filter manufacturer. Empty the collection bowl as necessary.
 - b. Change the element as often as necessary or every 500 hours.
 - c. If the bowl fills with water, change the primary and secondary element immediately.
2. Change secondary fuel filter every 500 hours.
 - a. Remove the spin-on filter by turning it counterclockwise with a filter wrench. Fill the new cartridge with fuel and install it after applying engine oil to gasket surface. Screw on until the gasket surface comes into contact with sealing surface of filter base. Then, tighten it two-thirds of a turn by hand. Do not overtighten.
 - b. Fuel filter part number is:

M673L3 & LD3 - 24-52020

Servicing

SP10. BLEEDING THE FUEL SYSTEM



CAUTION: Escaping diesel fuel under pressure can penetrate skin causing serious personal injury. Before disconnecting lines be sure to relieve all pressure. Before applying pressure, be sure all connections are tight and lines, pipes and hoses aren't damaged. Fuel escaping from a very small hole can be almost invisible. Use a piece of cardboard or wood, rather than hands, to search for suspected leaks. If injured by escaping fuel, see a doctor at once. Serious infection or reaction can develop if proper medical treatment isn't administered immediately.

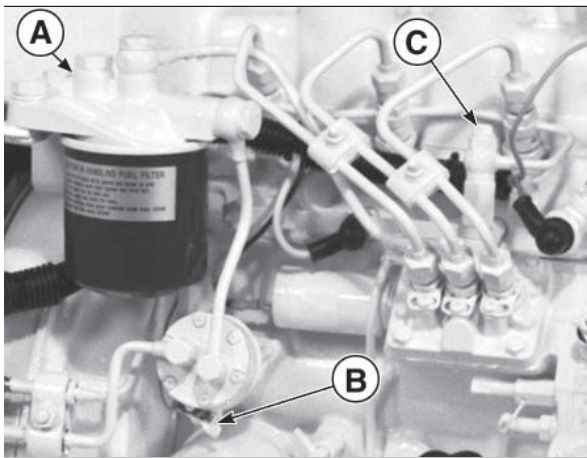

Figure 12: M673 Fuel System.

1. The fuel system is self-bleeding. However, any system may need manual bleeding when:
 - a. A new fuel filter is installed;
 - b. The engine has run out of fuel;
 - c. The fuel lines, injection pump or any other fuel system component has been removed and installed.
2. Loosen bleed screw "A" (Figure 12) on top of the filter. Pump hand primer "B" on fuel lift pump until pure fuel (no bubbles) escapes from bleed screw "A". Tighten bleed screw "A".
3. Loosen bleed screw "C". Pump hand primer "B" on fuel lift pump until pure fuel (no bubbles) escapes from bleed screw "C".
4. If the engine does not start after the above bleeding process, loosen a fuel line at the injector. Crank the engine until pure fuel escapes, then tighten the connection. Do each line **one at a time**.
5. After the engine has started, check for fuel leaks using a piece of cardboard.

Servicing

SP11. INJECTOR SERVICE

1. Injectors should be checked every 1000 hours, or more often as necessary. Check should be made by a Northern Lights dealer or local injection repair station.



CAUTION: *Escaping diesel fuel under pressure can have sufficient force to penetrate the skin causing serious personal injury. If injured by escaping diesel fuel, see a doctor at once.*

2. Injector removal:
 - a. Clean loose dirt from around the injectors and the fuel lines.
 - b. Relieve high pressure in the fuel lines by loosening the delivery line flare nuts at each injector (Figure 13).
 - c. Remove delivery lines by disconnecting from injectors and injection pump (Figure 14). Remove all lines as an assembly; do not remove the clamp. Cover the ends of the lines, the injector inlets and injection pump outlets to keep dirt out (Figure 15).
 - d. Remove the return line retaining bolts (Figure 16). Remove the return line (Figure 17).
 - e. Unscrew and remove the injectors (Figure 18).
NOTE: *Do not use pry bars to remove injectors from cylinder head.*
 - f. After removing the injectors, discard the copper sealing washers from the injector hole in the head (Figure 19). Cover holes to prevent dirt and debris from entering the cylinders.

3. Injector installation:
 - a. Install a new copper sealing washer in each injector hole (Figure 19).
 - b. Screw in injector and tighten to 43 or 50 ft/lbs (6 to 7 kgm) (Figure 20).
NOTE: *Overtightening can damage injector.*
 - c. Install return line using new copper sealing below each connection. Tighten return line retaining bolts to 22 - 30 ft/lbs.
 - d. Install delivery lines. Leave loose at injectors for bleeding.
 - e. Crank the engine to fill lines. Tighten lines at injectors. Start engine and check for leaks using a piece of paper or cardboard.
DO NOT use hand to check for leaks.

SP12. INJECTION PUMP

1. Since operating conditions may vary considerably, it is difficult to give a definite interval for checking the injection pump. But as a rule, pump settings, maximum speed, idle speed and exhaust smoke should be checked after every 2400 hours of operation. Service of the fuel injection pump should only be done if checks indicate pump malfunction.
2. Black smoke can be an indication of pump malfunction. Before servicing the pump, check other possible causes:
 - a. Check cleanliness of air filter.
 - b. Check valve clearances.
 - c. Clean and check injectors.
3. Any repair which involves disassembly of the injection pump must be carried out by specially trained mechanics with the proper tools and test equipment.

NOTE: *All warranties on the engine become null and void if the injection pump seals are broken by unauthorized persons.*

COOLING SYSTEM - GENERAL

NOTE: *Be sure to close the sea-cock before working on the engine cooling system.*



CAUTION: *The cooling water in the engine reaches extremely high temperatures. You must use extreme caution when working on hot engines to avoid burns. Allow the engine to cool before working on the cooling system. Open the filler cap carefully, using protective clothing when the engine is warm.*

Servicing

WATER QUALITY

1. Distilled, deionized, soft water is preferred for use in cooling systems. Bottled distilled water from a food store or water supplier is recommended. Tap water often has a high mineral content. Tap water should NEVER be put in a cooling system unless first tested by a water quality laboratory. Do not use water made by the reverse osmosis method unless it has been PH neutralized.

2. Here are acceptable water quality specifications:

Contaminates	Parts per Million	Grains per Gallon
Maximum Chlorides	40	2.5
Maximum Sulfates	100	5.9
Maximum Dissolved Solids	340	20.0
Maximum Total Hardness	170	10.0
PH Level 5.5 to 9.0		

3. If chlorides, sulfates or total dissolved solids are higher than the above given specification, the water must be distilled, demineralized, or deionized before it is used in a cooling system.
4. If total hardness is higher than 170 ppm and all other parameters are within the given specifications, the water must be softened before it is used to make coolant solution.

SP13. CHECK THE COOLANT LEVEL

1. Check the coolant level each day before starting the engine. Check the water level by removing the pressure cap from the expansion tank or radiator.
In order to give the cooling water an opportunity to expand, the level should be about 1 in. (2.5 cm) below the filler cap sealing surface when the engine is cold.
2. The pressure valve in the filler cap releases when the pressure is approximately 7 PSI (0.5 bar). Use a cap pressure tester to check cap if you suspect it is faulty.

Servicing



Figure 13: Remove delivery line flare nuts.



Figure 17: Remove return line.

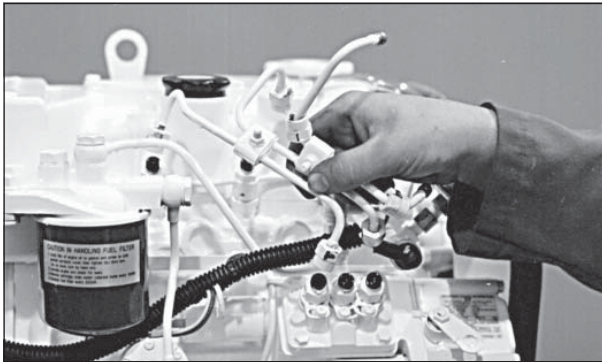

Figure 14: Remove delivery lines.



Figure 18: Unscrew injector.



Figure 15: Cover lines, inlets and injection pump outlets.



Figure 19: Remove and replace copper sealing washer.

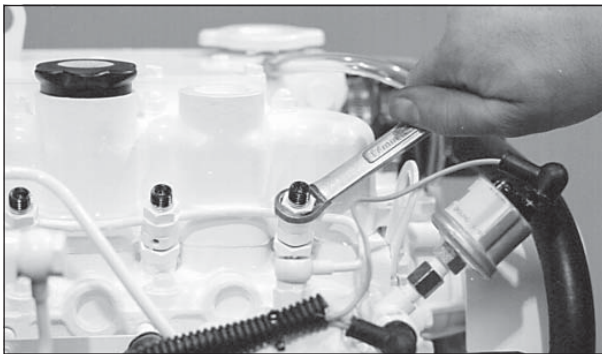

Figure 16: Remove return line nuts.



Figure 20: Reinstall injector. Torque to proper tightness.

Servicing

SP14. COOLING SYSTEM FLUSHING

1. Flush the cooling system every 2500 hours or every 12 months, whichever comes first.
 - a. Remove expansion tank cap and drain engine block.
 - b. Leave all drains open.
 - c. Pour clean water into expansion tank until water coming from drains is free of discoloration and sediment.
 - d. Let water drain completely.
 - e. Close drains and refill with recommended mixture.

NOTE: *Open sea cock before running engine.*

2. Coolant Specifications:
Use 50% water / 50% ethylene glycol antifreeze mix. Antifreeze mixture is recommended as a good year-round coolant, but not methyl alcohol based antifreeze because of its low boiling point. Also, antifreeze with high silicate should not be used as it could cause silica gelation problems.
3. Check hoses and connections and repair any leakage.

SP15. HEAT EXCHANGER

1. Clean the heat exchanger core once a year or after 2500 hours of operation.
2. Drain expansion tank and heat exchanger.
3. Remove heat exchanger end covers and remove core.
4. Clean the inside of exchanger core tubes using a metal rod. Flush, inspect and clean again if necessary.
5. Reassemble. Fill the cooling system, start the engine and check for leaks.

SP16. RAW WATER PUMP

1. Change the seawater pump impeller every 1000 hours, or as needed.
2. Remove the pump end cover. Pry out the impeller using needle-nose pliers or two screwdrivers. Be sure you remove all pieces of failed impeller.
NOTE: *Place some kind of protection under the screwdrivers in order not to damage the pump housing.*
3. Clean the inside of the housing.
4. Press in the new impeller and place the sealing washers in the outer end of the impeller center if this has not already been done.
5. Replace the cover using a new gasket or o-ring.
NOTE: *Make sure that there is always an extra impeller and cover gasket in reserve on board.*

GENERATOR ENDS

The maintenance and operation recommendations for the generator end are located on pages 19-22 under the heading "AC Generator".

ELECTRICAL SYSTEM - GENERAL

1. Never switch battery switch off or break the circuit between the alternator and batteries while the engine is running. Regulator damage can result.
2. Do NOT reverse the polarity of battery cables when installing the battery.
3. When welding on the unit, disconnect the AC and DC voltage regulator and battery. Isolate the leads.
4. Disconnect the battery cables when servicing the D.C. alternator.
5. Never test with a screwdriver, etc., against any terminal to see if it emits sparks.
6. Do not polarize the alternator or regulator.
7. A D.C. circuit breaker protects your control panel and wiring harness. It is located in the side of the generator junction box.

Servicing

GLOW PLUGS

1. Each cylinder is supplied with a glow plug which serves to heat the combustion chamber for starting.
2. To check the glow plugs, loosen the current carrying flat wire between the plus-poles of the glow plugs (Figure 21). Connect a D.C. test bulb between the plus-pole of the battery and the plus-pole of the glow plug. If the bulb lights up, the glow plug is functioning properly.
3. Check all glow plugs and replace any faulty ones.

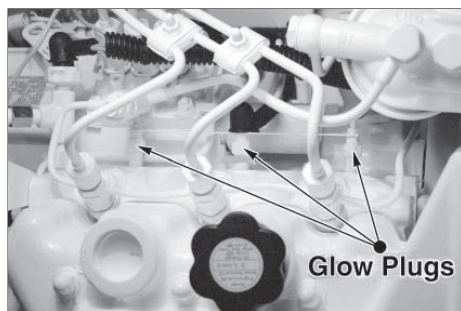

Figure 21: Glow plugs.

BOOSTER BATTERIES



CAUTION: Battery gas can explode.
Keep all flames and sparks away from batteries.

1. Before changing or using booster batteries, check battery electrolyte level. Add distilled water if necessary.
2. Booster and main batteries must have the same voltage rating.
3. First, connect positive (+) terminal of booster battery to positive (+) terminal of main battery. Then, connect negative (-) terminal of booster battery to ground on the engine block (see Figure 22).
4. Remove booster battery after starting engine.
5. Sealed batteries: See manufacturer charging and booster instructions.

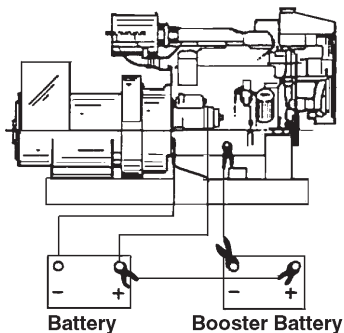

Figure 22:
Battery connections.

SP 17-18. BATTERY CARE

1. Check electrolyte level daily. Add distilled water to manufacturer's recommended level.
2. Batteries, cables and cable terminals should be checked and cleaned every 100 hours. Clean corrosion with a water and baking soda solution. Flush with clean water. Tighten terminals and grease them to inhibit corrosion.
3. Check the battery condition with a hydrometer every 250 hours.

SP19. WINTERIZING / OUT-OF-SERVICE

1. Drain fresh water and seawater cooling systems completely. Remember to shut off seacocks before opening drain cocks if the vessel is in the water.
2. Drain water supply lines and wet exhaust line.
3. Loosen the seawater pump cover and drain pump.
4. Fill the fuel tank or add biocide as per manufacturer's instructions.
5. Seal the air cleaner inlet, exhaust opening, crankcase breather pipe, and fuel tank vent with plastic bags and tape.
6. Store the set in a dry protected place. If unit must be stored outside, be sure it is well protected with a cover.
7. Change the crankcase oil and filter.
8. Loosen the alternator belt.
9. Disconnect and clean battery. Remove to warm storage place if possible.
10. Clean outside of unit. Paint any scratched or chipped surfaces. Put corrosion preventative on all exposed metal surfaces.

AC Generator - TF-276D

GENERAL

1. A Generator Set includes the engine, the generator, and the control or "J" box (Figure 23).
2. The generator and the control or "J" box produce the electrical power.
3. Generator excitation is provided by residual magnetism and electrical output voltage is controlled by the automatic voltage regulator (AVR) located in the control box (Figure 25, Item 2).

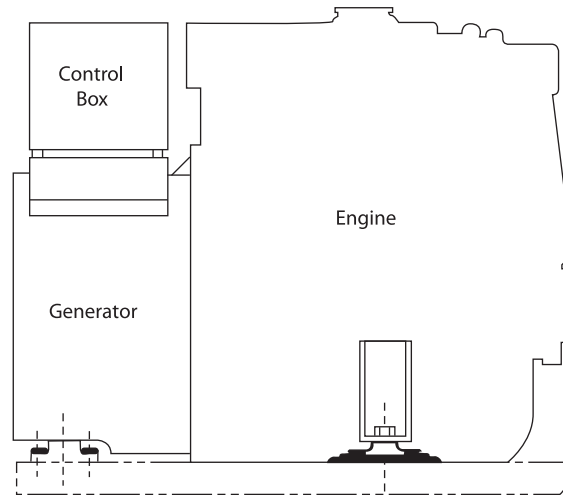

Figure 23: Composition.

GENERATOR (Figure 24)

1. Stator Core
2. Stator Coil
3. End Cover
4. Brush
5. Ball Bearing
6. Slip Ring
7. Frame
8. Coupling Plate
9. Field Coil
10. Field Core
11. Shaft
12. Ventilation Cover

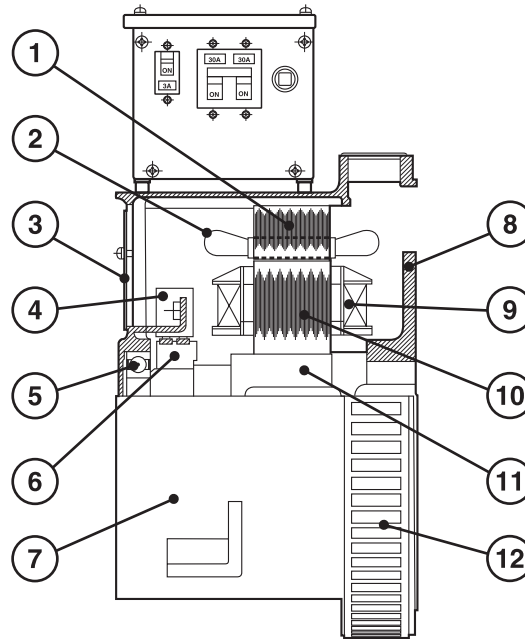

Figure 24: Generator Components.

CONTROL BOX (Figure 25)

1. Voltage Selector Terminal
2. Automatic Voltage Regulator (AVR)
3. 12 Volt DC Circuit Breaker
4. AC Circuit Breaker
5. AVR Circuit Breaker
6. Output Terminal Board

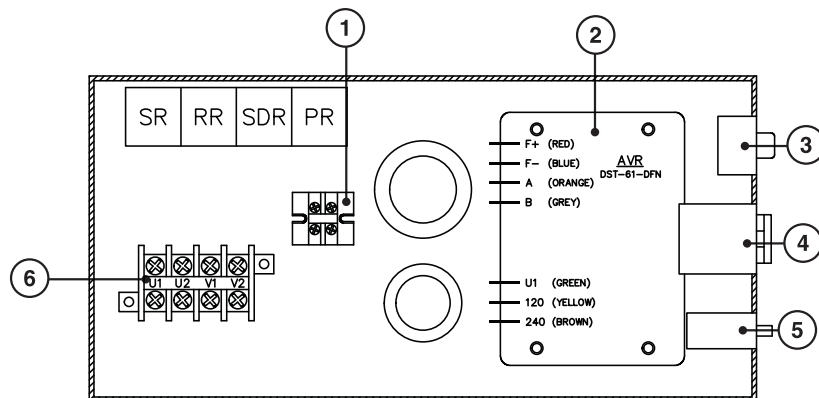

Figure 25: Control Box Components.

AC Generator - TF-276D

CONNECTIONS

1. 120 Volt Output:

- a. 120 volt output can be selected by connecting the terminals of the control terminal board to 120 (Figure 26).

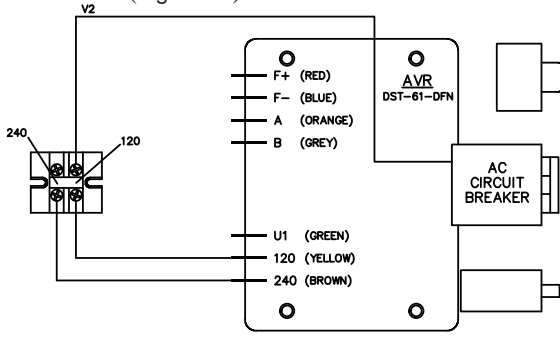

Figure 26: Control Terminal Board, 120 Volt Output

- b. Connect U1 to U2 and V1 to V2 on the output terminal board (Figure 27). Connect 120 volt output leads to terminals U1 and V2.

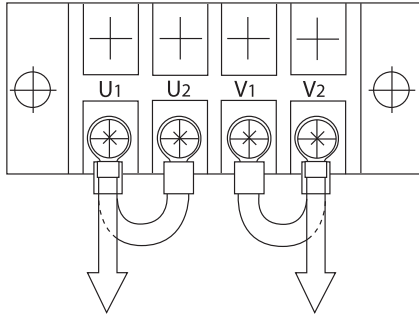

Figure 27: Output Terminal Board, 120 Volt Output

2. 240 Volt Output:

- a. 240 volt output can be selected by connecting the terminals of the control terminal board to 240 (Figure 28).

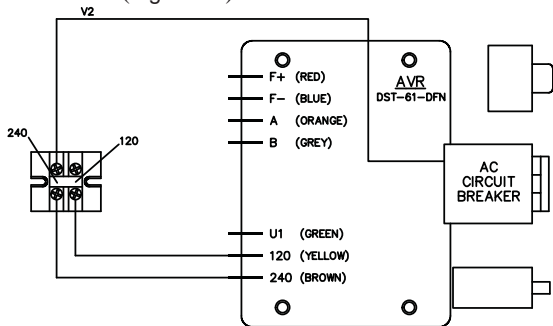

Figure 28: Voltage Selector Terminal, 240 Volt Output

- b. Connect U2 to V1 on the output terminal board (Figure 29).

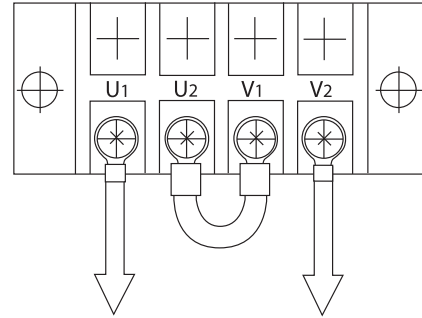

Figure 29: Output Terminal Board, 240 Volt Output

3. 120/240 Volt Output

- a. Connect the control terminal board for 240 volts (Figure 30).

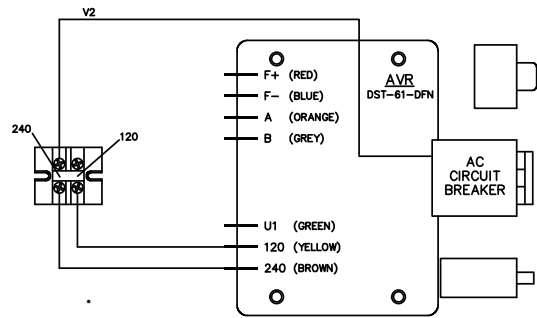

Figure 30: Control Terminal Board, 120/240 Volt Output

- b. Connect U2 and V1 on the output board (Figure 31). Connect output leads to U1 and V2 and neutral lead to V1 (or U2). 240 volt output is available from the leads connected to U1 and V2. The 120 volt load should be divided as equally as possible between two 120 volt circuits.

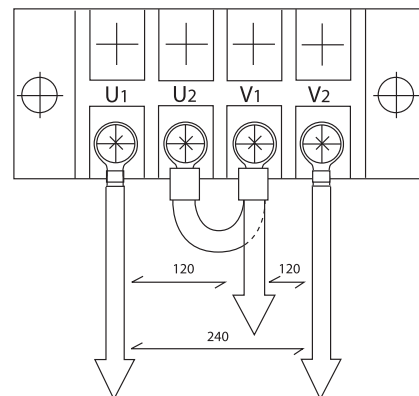

Figure 31: Output Terminal Board, 120/240 Volt Output

AC Generator - TF-276D

OPERATION

In order to ensure a long, trouble-free life, the generator must be operated properly and the specified maintenance must be performed.

OPERATING ENVIRONMENT

Always keep electrical equipment clean. Moisture, salt, dust, and oil will damage the generator. The operating environment must be kept as clean and moisture free as possible.

VENTILATION

Good ventilation is important for proper generator operation. When installing the generator set, be sure the ambient temperature does not exceed 40°C (104°F) during operation.

MAINTENANCE

Proper and effective maintenance is required to ensure trouble-free operation. In addition to the above items, the following are required:

1. Periodically check all bolts and nuts for proper torque. This is especially true for coupling bolts.
2. Be sure to keep the generator area clean and dry.
 - a. Dust and foreign material may reduce the flow of cooling air, reducing heat dissipation and causing the generator to overheat.
 - b. If electrically conductive debris accumulates on the windings, or if moisture or salt water are absorbed into the windings, the windings may short or ground, reducing voltage output.
 - c. Wiping is the only effective method for removing dust and foreign materials. Use a clean, lint-free piece of cloth.
3. If the generator has not been operated for an extended period of time, check the insulation resistance of each stator coil and the rotor. Disconnect the AVR from the generator when performing this test.

4. Voltage Adjustment

- a. If there is some voltage, but it does not build up to rated voltage, voltage adjustment can be made using the "hand trimmer" in the AVR (Figure 32).
- b. The normal voltage setting at no load is 121 volts at 62 Hertz or 242 volts at 62 Hertz.

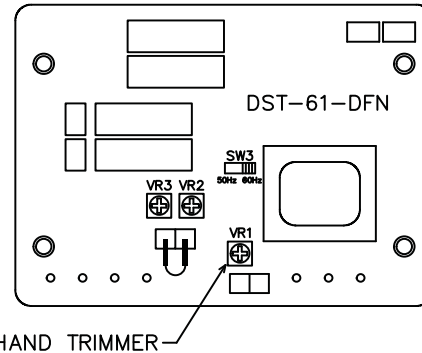

Figure 32: Hand Trimmer Location on AVR.

5. Check the ball bearing in the generator end.
 - a. Listen for unusual noise.
 - b. Abnormal temperature rise can be noted by discoloration.
 - c. If the bearing is failing, it must be replaced.
 - d. Generator bearing should be replaced by your Northern Lights dealer at 10,000 hours.
6. Check the brushes
 - a. The carbon brushes gradually wear with use, so they must be inspected periodically and replaced as necessary.
 - b. If the brushes are excessively worn as to expose the pigtail (Figure 33), sparking will occur at the surface of the slip ring, causing surface damage. Therefore, periodic inspection of the brushes is important.
 - c. Normally, the brushes will have to be replaced with a new brush assembly within 3,000 hours.

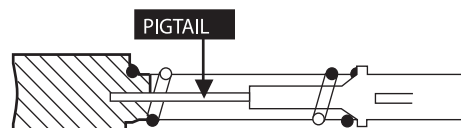

Figure 33: Brush Pigtail.

AC Generator - TF-276D

7. Replacing Brushes
 - a. Shut down the generator. Remove four screws and end cover of the generator.
 - b. Brush assembly is black plastic with two wires leading to it. It is located at ten o'clock and is held in position by two screws (Figure 34). Remove the screws and unplug leads.

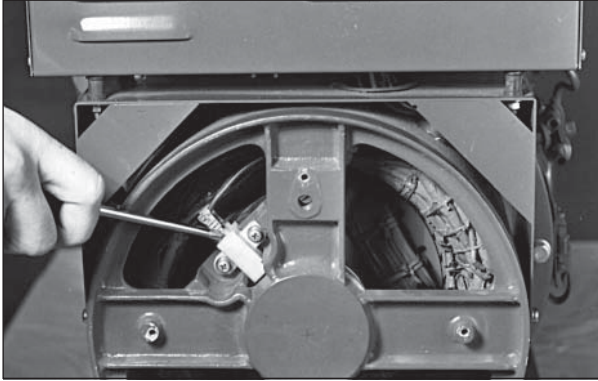

Figure 34: Brush Location.

- c. Attach leads to new brush assembly and install it with the plastic ears towards the front of the generator.

NOTE: Be sure to connect wire J to terminal J, and connect wire K to terminal K.

8. Generator Protection

To protect the generator and AVR from unbalanced loads and over loads, two 20 amp breakers are placed in the output circuit and one 3 amp breaker is placed in the AVR sensing circuit (Figure 35).

9. Parts: See Parts Book for complete list
 - a. Bearing
Part #22-68305
 - b. Brush assembly
Part #22-68304
10. Test Specifications: See Wiring Diagram(s)
 - a. Resistance of J-K
16.6 ohm at 20°C (68°F)
 - b. Resistance of A-B
0.25 ohm at 20°C (68°F)
 - c. Resistance of U1-V2
0.56 ohm at 20°C (68°F)
 - d. No load voltage setting
242V or 121V at 62 Hz with cold generator

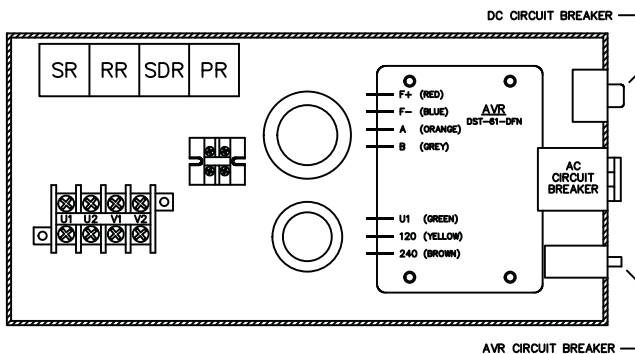

Figure 35: Breaker Locations.

Troubleshooting

DC ELECTRICAL SYSTEM

PROBLEM	POSSIBLE CAUSE	RECOMMENDATION(S)
Battery Will Not Charge	Loose or corroded connections	<ul style="list-style-type: none"> • Clean and tighten battery connections.
	Sulfated or worn out batteries	<ul style="list-style-type: none"> • Check specific gravity of each battery. • Check electrolyte level of each battery.
	Loose or defective alternator belt	<ul style="list-style-type: none"> • Adjust belt tension. • Replace belt.
Starter Inoperative	Check DC circuit breaker	<ul style="list-style-type: none"> • If the breaker is tripped, reset it.
	Loose or corroded connections	<ul style="list-style-type: none"> • Clean and tighten loose battery and harness plug connection.
	Low battery output	<ul style="list-style-type: none"> • Check specific gravity of each battery. • Check electrolyte level of each battery.
	Defective electrical system ground wire	<ul style="list-style-type: none"> • Repair or replace.
Starter Cranks Slowly	Low battery output	<ul style="list-style-type: none"> • Battery is too small. • Battery cables are too small.
	Check specific gravity of each battery	<ul style="list-style-type: none"> • Replace battery if necessary.
	Check electrolyte level of each battery	<ul style="list-style-type: none"> • If low, fill cells with distilled water.
	Loose or corroded connections	<ul style="list-style-type: none"> • Clean and tighten loose connections.
	Crankcase oil too heavy	<ul style="list-style-type: none"> • Fill with oil of appropriate viscosity.
Entire Electrical System Does Not Function	Check DC circuit breaker	<ul style="list-style-type: none"> • If breaker is tripped, reset it.
	Faulty connection	<ul style="list-style-type: none"> • Clean and tighten battery and harness plug connections.
	Sulfated or worn out batteries	<ul style="list-style-type: none"> • Check specific gravity and electrolyte level of each battery.
	Dead Battery	<ul style="list-style-type: none"> • Charge battery.

If you cannot correct problems with these procedures, see your **Northern Lights** dealer.

Troubleshooting

ENGINE

PROBLEM	POSSIBLE CAUSE	RECOMMENDATION(S)
Engine Hard to Start or Will Not Start	Improper starting procedure	<ul style="list-style-type: none"> • See starting section of this manual. Take special note of Bypass Switch operation.
	No fuel	<ul style="list-style-type: none"> • Check level of fuel in fuel tank.
	Low battery output	<ul style="list-style-type: none"> • Check electrolyte level and condition.
	Excessive resistance in starting circuit	<ul style="list-style-type: none"> • Clean and tighten all battery connections.
	Crankcase oil too heavy	<ul style="list-style-type: none"> • Use oil of proper viscosity.
	Improper type of fuel	<ul style="list-style-type: none"> • Consult fuel supplier and use proper type of fuel for operating condition.
	Water, dirt or air in fuel system	<ul style="list-style-type: none"> • Drain, flush, fill and bleed system.
	Clogged primary or secondary fuel filter element	<ul style="list-style-type: none"> • Clean or replace primary filter element, replace secondary filter element.
	Dirty or faulty injection nozzles	<ul style="list-style-type: none"> • Have your dealer check injection nozzles.
Fuel injected but no ignition	<ul style="list-style-type: none"> • Glow plug malfunction. • Injection timing not correct. • Low cylinder compression pressure. 	
Engine Runs Irregularly or Stalls Frequently	Below normal engine temperature	<ul style="list-style-type: none"> • Remove and check thermostat.
	Clogged primary or secondary fuel filter element	<ul style="list-style-type: none"> • Clean or replace primary filter element, replace secondary filter element.
	Water or dirt in the fuel system	<ul style="list-style-type: none"> • Drain, flush, fill and bleed system.
	Dirty or faulty injection nozzles	<ul style="list-style-type: none"> • Have your dealer check injection nozzles.
	Air in fuel system	<ul style="list-style-type: none"> • Inspect clamps and hoses on suction side of fuel pump for air leak.
	Improper type of fuel	<ul style="list-style-type: none"> • Consult fuel supplier and use proper type of fuel for operating condition.
	Low idle, not stable	<ul style="list-style-type: none"> • Uneven compression cylinders.
Lack of Engine Power	Intake air restriction	<ul style="list-style-type: none"> • Service air cleaner.
	Clogged primary or secondary fuel filter element	<ul style="list-style-type: none"> • Clean or replace primary filter element, replace secondary filter element.
	Improper type of fuel	<ul style="list-style-type: none"> • Consult fuel supplier and use proper type of fuel for operating conditions.
	Overheated engine	<ul style="list-style-type: none"> • See “Engine Overheats” in next category.
	Below normal engine temperature	<ul style="list-style-type: none"> • Remove and check thermostat.
	Improper valve clearance	<ul style="list-style-type: none"> • Reset valves. Best done by dealer.
	Dirty or faulty injection nozzles	<ul style="list-style-type: none"> • Replace injectors. Best done by dealer. • See your local dealer.

Troubleshooting

ENGINE

PROBLEM	POSSIBLE CAUSE	RECOMMENDATION(S)
Lack of Engine Power (continued)	Cylinder compression pressure low	<ul style="list-style-type: none"> • Adjust valve clearance. • Adjust nozzle holder alignment.
Engine Overheats	Low coolant level or cooling system defective	<ul style="list-style-type: none"> • Fill tank or radiator to proper level. • Check hoses for loose connections and leaks. • Fan belt slipping.
	Keel cooling tubes have been painted	<ul style="list-style-type: none"> • Remove paint from tubes.
	Cooling system needs flushing	<ul style="list-style-type: none"> • Flush cooling system.
	Defective thermostat	<ul style="list-style-type: none"> • Remove and check thermostat.
	Defective temperature gauge	<ul style="list-style-type: none"> • Check water temperature with thermometer and replace gauge if necessary.
	Water pump impeller worn/broken	<ul style="list-style-type: none"> • Check impeller and replace if necessary.
Engine Knocks	Insufficient oil	<ul style="list-style-type: none"> • Call your dealer.
	Injection pump out of time	<ul style="list-style-type: none"> • Call your dealer.
	Below normal engine temperature	<ul style="list-style-type: none"> • Check your thermostats. • Check water temperature to see if temperature gauge is working properly.
	Engine overheating	<ul style="list-style-type: none"> • See "Engine Overheating" section.
High Fuel Consumption	Improper type of fuel	<ul style="list-style-type: none"> • Use correct fuel for temperature.
	Clogged or dirty air cleaner	<ul style="list-style-type: none"> • Service air cleaner.
	Improper valve clearance	<ul style="list-style-type: none"> • See your dealer.
	Injection nozzles dirty	<ul style="list-style-type: none"> • See your dealer.
	Injection pump out of time	<ul style="list-style-type: none"> • See your dealer.
	Engine overloaded	<ul style="list-style-type: none"> • Check load usage.
	Engine not at proper temperature	<ul style="list-style-type: none"> • Check your thermostats. • Check water temperature with thermometer and replace gauge if necessary.
Below Normal Engine Temperature	Thermostats not working properly	<ul style="list-style-type: none"> • Check thermostats.
	Temperature gauge not working properly	<ul style="list-style-type: none"> • Check water temperature with thermometer.

If you cannot correct problems with these procedures, see your **Northern Lights** dealer.

Troubleshooting

ENGINE

PROBLEM	POSSIBLE CAUSE	RECOMMENDATION(S)
Low Oil Pressure	Low oil level	• Fill crankcase to proper level.
	Clogged filter and strainer or worn bearings and oil pump	• Repair or replace.
	Improper type of oil	• Drain and fill crankcase with correct oil.
	Partially plugged oil filter	• Replace filter.
High Oil Consumption	Break-in period	• Oil consumption decreases after break in.
	Crankcase oil too light	• Use proper viscosity oil.
	Oil leaks	• Check for leaks in lines around gaskets and drain plug.
Engine Emits Black or Gray Exhaust Smoke	Clogged or dirty air cleaner	• Service air cleaner.
	Defective muffler (back pressure too high)	• Have dealer check back pressure.
	Improper fuel	• Use correct fuel for temperature.
	Injection nozzles dirty	• See your dealer.
	Engine out of time	• See your dealer.
Engine Emits White Smoke	Improper fuel	• Use correct fuel for temperature.
	Cold engine	• Warm up engine to normal operating temperature.
	Defective thermostat	• Remove and check thermostat.
	Engine out of time	• See your dealer.

If you cannot correct problems with these procedures, see your **Northern Lights** dealer.

Northern Lights Marine Data

Model:

RPM
kW Rating
Frequency (Hz)

	M673L3		M673LD3	
	1800 6.0 60	1500 5.0 50	1800 5.0 60	1500 4.5 50
GENERAL INFORMATION				
Cylinders	3	3	3	3
Displacement	46.4 in ³ (0.761 ltr)	46.4 in ³ (0.761 ltr)	46.4 in ³ (0.761 ltr)	46.4 in ³ (0.761 ltr)
Cycle	4	4	4	4
Bore	2.64 in (67 mm)	2.64 in (67 mm)	2.64 in (67 mm)	2.64 in (67 mm)
Stroke	2.83 in (72 mm)	2.83 in (72 mm)	2.83 in (72 mm)	2.83 in (72 mm)
Rotation (facing flywheel)	CCW	CCW	CCW	CCW
Compression Ratio	23.5:1	23.5:1	23.5:1	23.5:1
Crankcase Capacity w/ Oil Filter	3.2 qts (3.0 ltr)	3.2 qts (3.0 ltr)	3.2 qts (3.0 ltr)	3.2 qts (3.0 ltr)
Aspiration	Natural	Natural	Natural	Natural
Dry Weight / Complete Unit	362 lbs (164 kg)	362 lbs (164 kg)	362 lbs (164 kg)	362 lbs (164 kg)
Height	20.25 in (514.5 mm)	20.25 in (514.5 mm)	20.25 in (514.5 mm)	20.25 in (514.5 mm)
Width	19.5 in (495 mm)	19.5 in (495 mm)	19.5 in (495 mm)	19.5 in (495 mm)
Length	28.5 in (725 mm)	28.5 in (725 mm)	28.5 in (725 mm)	28.5 in (725 mm)
COOLING SYSTEM				
Approximate Cooling System Capacity	.5 gal (2 ltr)	.5 gal (2 ltr)	.5 gal (2 ltr)	.5 gal (2 ltr)
Minimum Through-Hull Diameter	0.75 in (19 mm)	0.75 in (19 mm)	0.75 in (19 mm)	0.75 in (19 mm)
Raw Water Pump Inlet Hose I.D.	0.75 in (19 mm)	0.75 in (19 mm)	0.75 in (19 mm)	0.75 in (19 mm)
Minimum Seawater Discharge	0.75 in (19 mm)	0.75 in (19 mm)	0.75 in (19 mm)	0.75 in (19 mm)
Heat Rejection to Jacket Water	350 BTU/min	250 BTU/min	350 BTU/min	250 BTU/min
Fresh Water Pump Capacity	5.0 gal/min (18.92 ltr/min)	4.2 gal/min (15.77 ltr/min)	5.0 gal/min (18.92 ltr/min)	4.2 gal/min (15.77 ltr/min)
Maximum Seawater Pump Suction Head	39 in (1 m)	39 in (1 m)	39 in (1 m)	39 in (1 m)
Seawater Pump Capacity	8.0 gal/min (30 ltr/min)	7.0 gal/min (26 ltr/min)	8.0 gal/min (30 ltr/min)	7.0 gal/min (26 ltr/min)
Keel Cooler Turbo Tube Length	4 ft (1.2 m)	4 ft (1.2 m)	4 ft (1.2 m)	4 ft (1.2 m)
Keel Cooler Head Diameter	0.75 in NPT (19.1 mm)	0.75 in NPT (19.1 mm)	0.75 in NPT (19.1 mm)	0.75 in NPT (19.1 mm)
Keel Cooler Water Hose I.D. Discharge and Suction	1.0 in (25 mm)	1.0 in (25 mm)	1.0 in (25 mm)	1.0 in (25 mm)

AC Wiring Diagrams

100/200-120/240VAC 1 ϕ 50/60 HZ

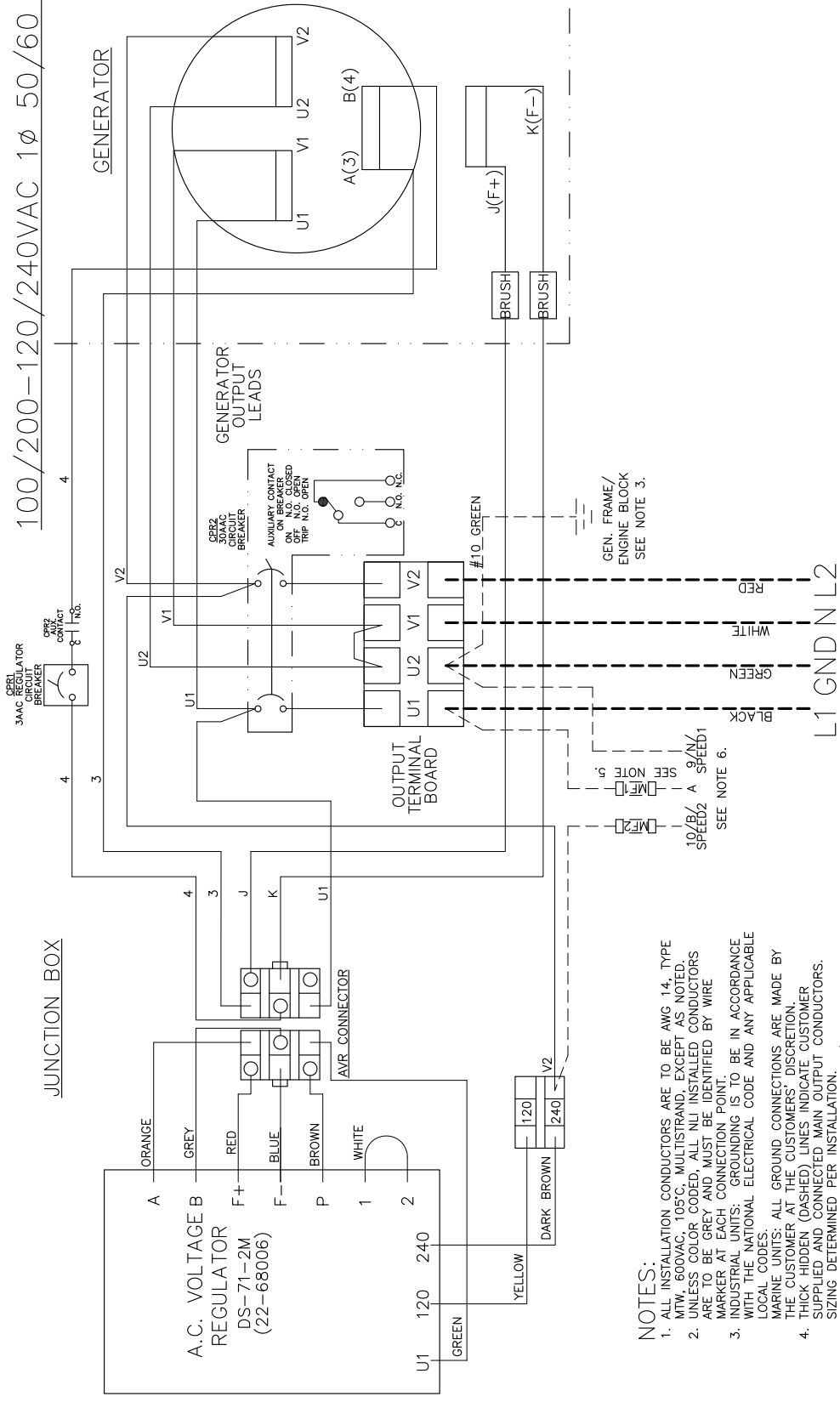

AC Engine Wiring Diagram
 100-120/ 200-240 Volts AC
 50/60 Hz
 Drawing #B-6103J

Wiring diagrams are subject to change without notice.

- NOTES:**
1. ALL INSTALLATION CONDUCTORS ARE TO BE AWG 14, TYPE MTW, 600VAC, 105°C, MULTISTRAND, EXCEPT AS NOTED. UNLESS COLOR CODED, ALL NLI INSTALLED CONDUCTORS ARE TO BE GREY AND MUST BE IDENTIFIED BY WIRE MARKER AT EACH CONNECTION POINT.
 2. INDUSTRIAL UNITS: GROUNDING IS TO BE IN ACCORDANCE WITH THE NATIONAL ELECTRICAL CODE AND ANY APPLICABLE LOCAL CODES.
 3. MARINE UNITS: ALL GROUND CONNECTIONS ARE MADE BY THE CUSTOMER AT THE CUSTOMERS' DISCRETION.
 4. THICK HIDDEN (DASHED) LINES INDICATE CUSTOMER SUPPLIED AND CONNECTED MAIN OUTPUT CONDUCTORS. SIZING DETERMINED PER INSTALLATION.
 5. ONLY MODULE FUSES 1 AND 2 ARE TO BE 1A/250V, TYPE ABC. PANELS MOUNTED OUTSIDE OF THE GENERATOR J-BOX.
 6. CONNECTION POINTS A, B, N, SPEED1, AND SPEED 2 REFER TO WAVENET AND S-GSC400 PANELS. CONNECTION POINTS 9 AND 10 REFER TO S-GSC300 PANELS. OMIT A AND LINKED FUSE FOR S-GSC300 INSTALLATIONS.

AC Wiring Diagrams

220VAC 1Ø 50 HZ

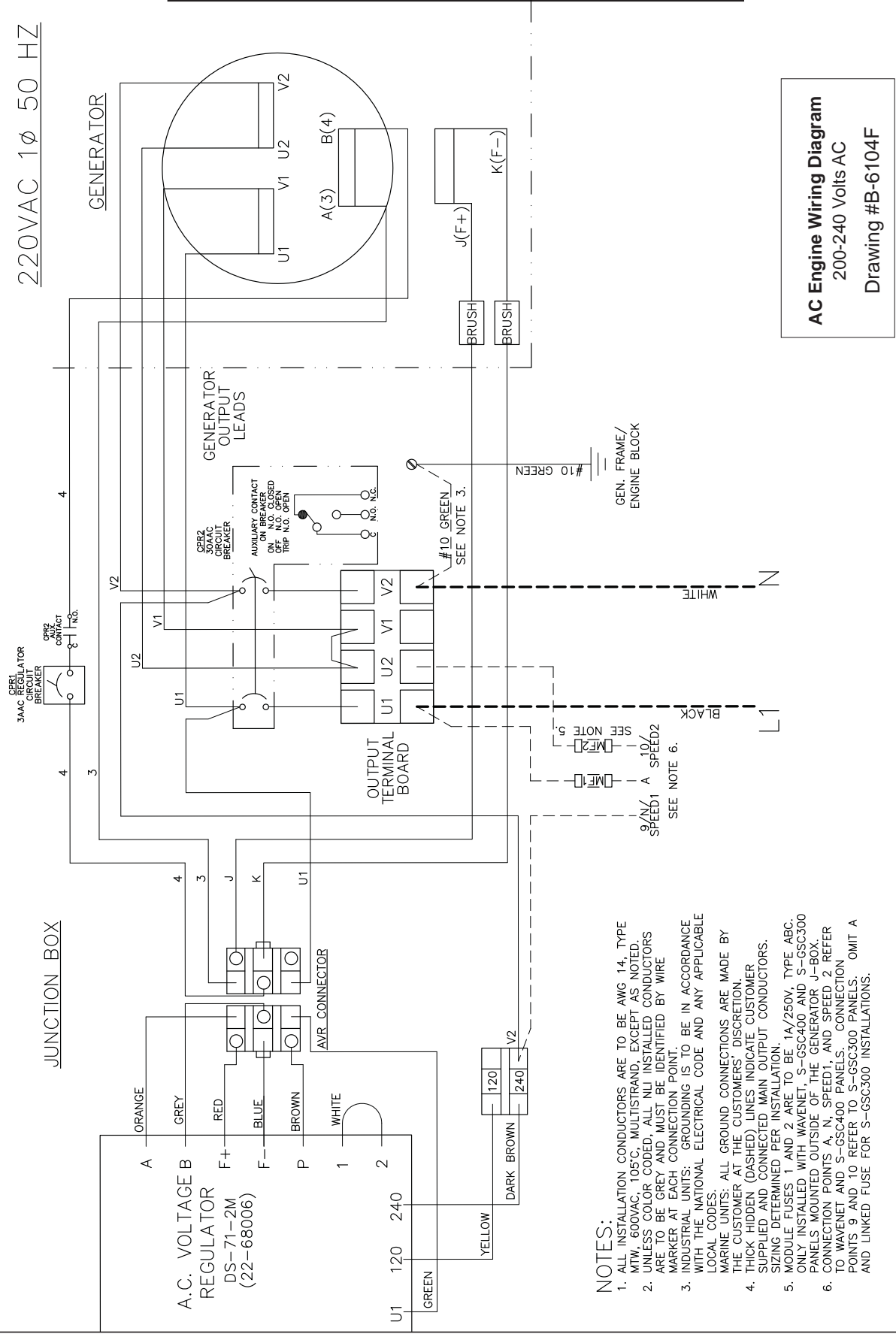

AC Engine Wiring Diagram
200-240 Volts AC
Drawing #B-6104F

Wiring diagrams are subject to change without notice.

- NOTES:**
1. ALL INSTALLATION CONDUCTORS ARE TO BE AWG 14, TYPE MTW, 600VAC, 105°C, MULTISTRAND EXCEPT AS NOTED. UNLESS COLOR CODED, ALL NEW INSTALLED CONDUCTORS ARE TO BE GREY AND MUST BE IDENTIFIED BY WIRE MARKER AT EACH CONNECTION POINT.
 2. INDUSTRIAL UNITS: GROUNDING IS TO BE IN ACCORDANCE WITH THE NATIONAL ELECTRICAL CODE AND ANY APPLICABLE LOCAL CODES.
 3. MARINE UNITS: ALL GROUND CONNECTIONS ARE MADE BY THE CUSTOMER AT THE CUSTOMER'S DISCRETION.
 4. THICK HIDDEN (DASHED) LINES INDICATE CUSTOMER SUPPLIED AND CONNECTED MAIN OUTPUT CONDUCTORS. SIZING DETERMINED PER INSTALLATION.
 5. MODULE FUSES 1 AND 2 ARE TO BE 1A/250V, TYPE ABC. ONLY INSTALLED WITH WAVENET, S-GSC400 AND S-GSC300 PANELS MOUNTED OUTSIDE OF THE GENERATOR J-BOX.
 6. CONNECTION POINTS A, N, SPEED1, AND SPEED 2 REFER TO WAVENET AND S-GSC400 PANELS. CONNECTION POINTS 9 AND 10 REFER TO S-GSC300 PANELS. OMIT A AND LINKED FUSE FOR S-GSC300 INSTALLATIONS.

AC Wiring Diagrams

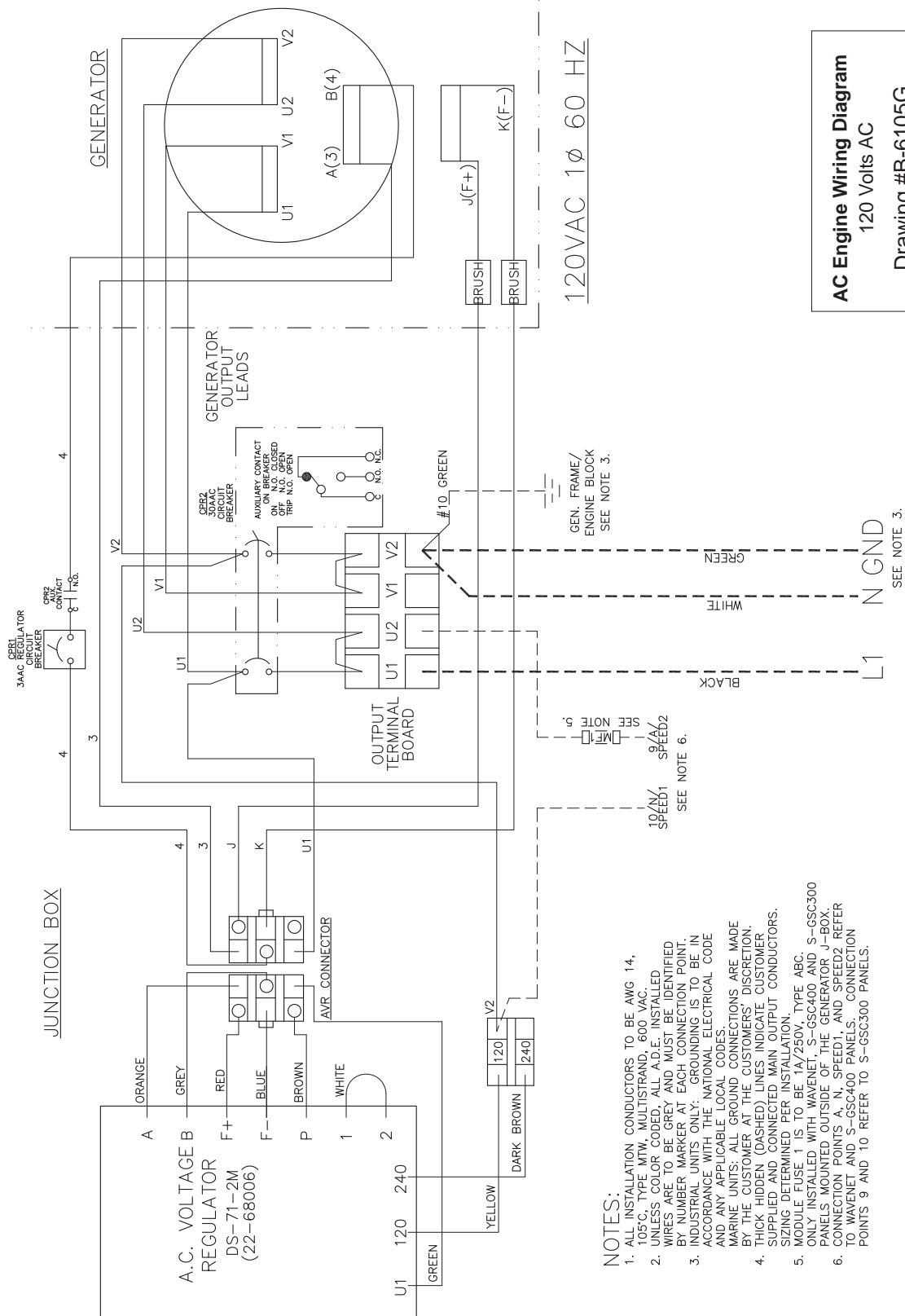

AC Engine Wiring Diagram
120 Volts AC
Drawing #B-6105G

Wiring diagrams are subject to change without notice.

NOTES:

1. ALL INSTALLATION CONDUCTORS TO BE AWG 14, 105°C, TYPE MTW, MULTISTRAND, 600 VAC.
2. UNLESS COLOR CODED, ALL A.D.E. INSTALLED WIRES ARE TO BE GREY AND MUST BE IDENTIFIED BY NUMBER MARKER AT EACH CONNECTION POINT.
3. INDUSTRIAL UNITS ONLY: GROUNDING IS TO BE IN ACCORDANCE WITH THE NATIONAL ELECTRICAL CODE AND ANY APPLICABLE LOCAL CODES.
4. MARINE UNITS: ALL GROUND CONNECTIONS ARE MADE BY THE CUSTOMER AT THE CUSTOMER'S DISCRETION. THICK HIDDEN (DASHED) LINES INDICATE CUSTOMER SUPPLIED AND CONNECTED MAIN OUTPUT CONDUCTORS. SIZING DETERMINED PER INSTALLATION.
5. MODULE FUSE 1 IS TO BE 1A/250V, TYPE ABC. ONLY INSTALLED WITH WAVENET, S-GSC400 AND S-GSC300 PANELS MOUNTED OUTSIDE OF THE GENERATOR J-BOX.
6. CONNECTION POINTS A, N, SPEED1, AND SPEED2 REFER TO WAVENET AND S-GSC400 PANELS. CONNECTION POINTS 9 AND 10 REFER TO S-GSC300 PANELS.

DC Wiring Diagrams

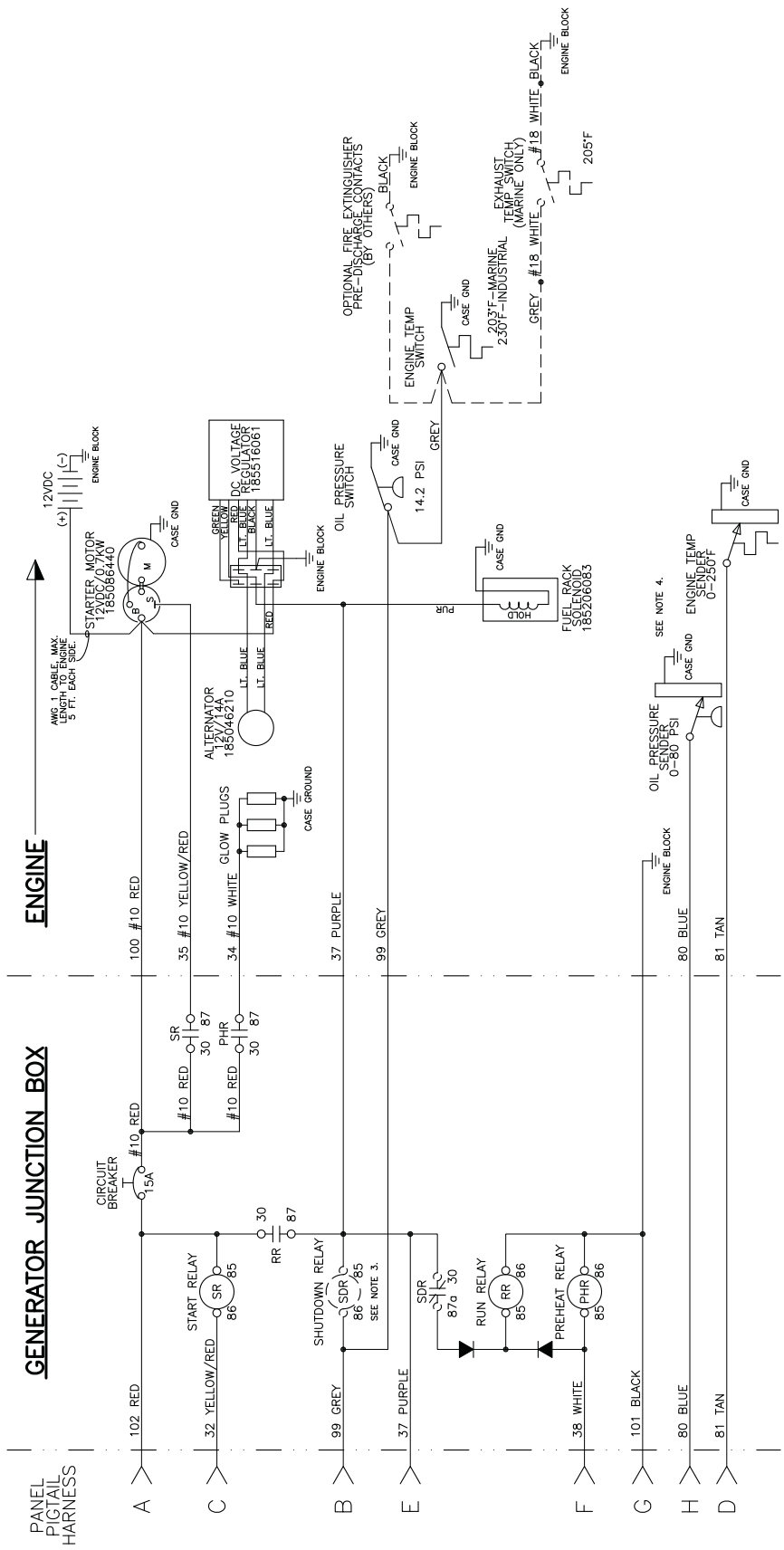

- NOTES:**
1. ALL INSTALLATION CONDUCTORS ARE TO BE AWG 14, TYPE MTW, 600VAC, 105°C, MULTISTRAND, EXCEPT THE ENGINE WIRE HARNESS, TWISTED PAIRS AND AS NOTED.
 2. UNLESS COLOR CODED, ALL 'NLI' INSTALLED CONDUCTORS ARE TO BE GREY AND MUST BE IDENTIFIED BY WIRE MARKER.
 3. EACH CONNECTION POINT (SDR) AS SHOWN WHEN USING WIRE HARNESS, CEC400, CEC400R/WAVENET PANELS, WITH 5 GAUGED CONTROL PANELS ARE USED, DUAL STATION SENDERS MUST BE INSTALLED.
 4. IF TWO GAUGED CONTROL PANELS ARE USED, DUAL STATION SENDERS MUST BE INSTALLED.

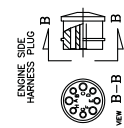

DC Engine Wiring Diagram
12 Volts DC Standard Ground
Drawing #B-9873

Wiring diagrams are subject to change without notice.

DC Wiring Diagrams

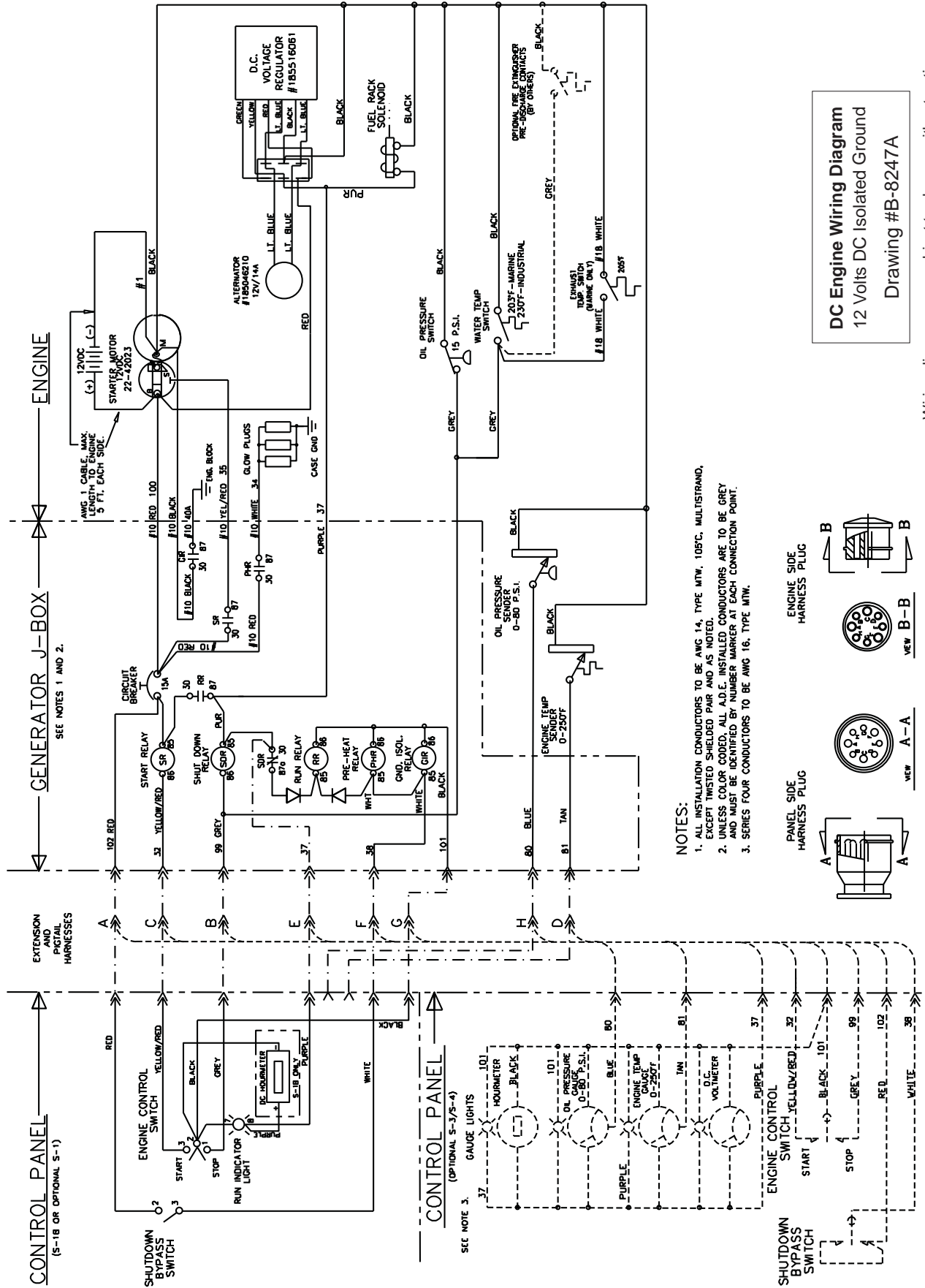

- NOTES:**
1. ALL INSTALLATION CONDUCTORS TO BE AWG 14, TYPE MTW, 105C, MULTISTRAND, EXCEPT TWISTED SHIELDED PAIR AND AS NOTED.
 2. UNLESS COLOR CODED, ALL A.D.E. INSTALLED CONDUCTORS ARE TO BE GREY AND MUST BE IDENTIFIED BY NUMBER MARKER AT EACH CONNECTION POINT.
 3. SERIES FOUR CONDUCTORS TO BE AWG 16, TYPE MTW.

DC Engine Wiring Diagram
 12 Volts DC Isolated Ground
 Drawing #B-8247A

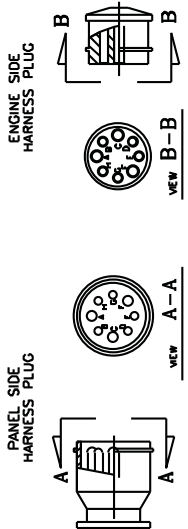

Wiring diagrams are subject to change without notice.

DC Wiring Diagrams

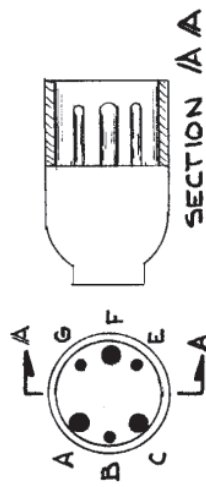
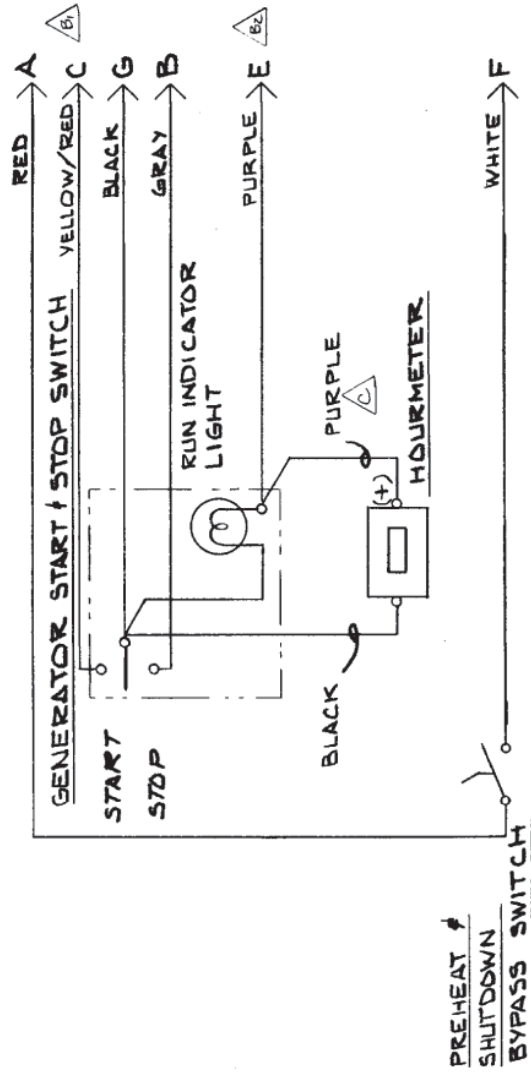

MOLED 6 PIN PLUG (BLACK)

DC Engine Wiring Diagram
S-1B 12 Volt
Drawing #A-3170

Wiring diagrams are subject to change without notice.

DC Wiring Diagrams

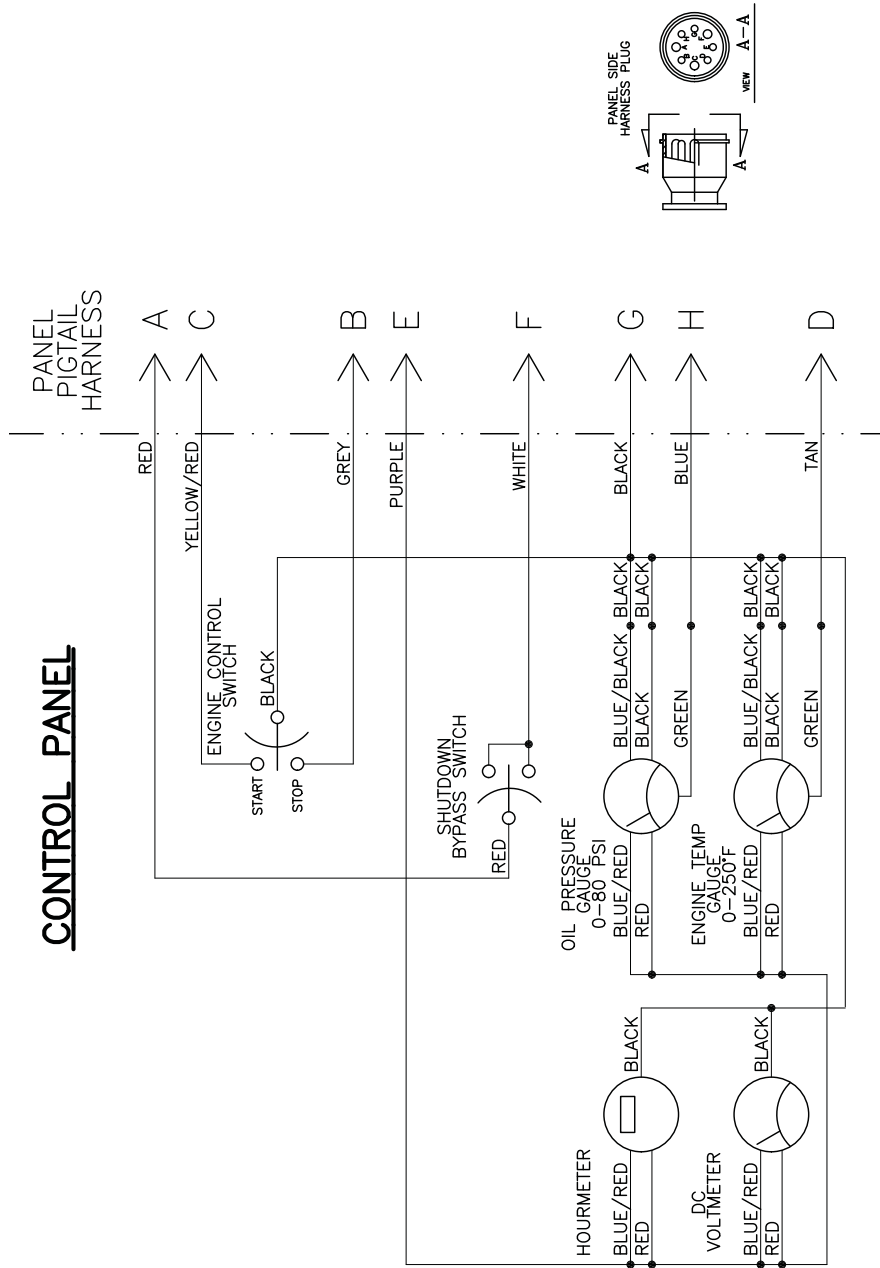

NOTES:

1. ALL INSTALLATION CONDUCTORS ARE TO BE AWG 14, TYPE MTW, 600VAC, 105°C, STRANDED, EXCEPT AS NOTED.

DC Engine Wiring Diagram
S-3C 12 Volt
Drawing #A-12616

Wiring diagrams are subject to change without notice.



4420 14th Ave. NW., Seattle WA 98107

Tel: (206) 789-3880 • 1-800-762-0165 • www.northern-lights.com

Northern Lights and Lugger are registered trademarks of Northern Lights, Inc.

© 2013 All rights reserved. Litho USA.